



Harnessing the power of water
Power and automation solutions
for hydropower plants



ABB is a leading provider of integrated power and automation solutions for all types of power generation plants. With an extensive offering that includes electrical balance of plant, automation, instrumentation and control systems, and service - along with more than 125 years of expertise and innovation and a presence in over 100 countries - ABB helps to optimize performance, improve reliability, enhance efficiency and minimize environmental impact throughout the plant lifecycle.



Complete power and automation solutions for hydropower plants

ABB is a leading supplier of power and automation solutions for hydropower plants.

We have one of the largest installed bases in the industry, market and technology leadership in power and automation technologies, and unrivaled application know-how and process expertise.

Our scope of supply ranges from integrated instrumentation, control and electrical solutions to complete electro-mechanical packages for water-to-wire projects – all backed up by ABB's extensive global network of expertise and lifecycle services.

Renewable, emission-free energy

Hydropower is the world's most widely used form of renewable energy. It produces around 20 percent of the world's electric power and accounts for almost 90 percent of electricity generated from renewable sources. It is clean, sustainable and emission-free.

Hydropower is uniquely flexible. It generates power in a wide range of capacities – from small plants of a few hundred kilowatts to medium-sized plants of tens of megawatts to giants like the 18-gigawatt Three Gorges in China – the largest power generation facility on earth. It is also the only type of power generation that enables energy to be stored on a grid-scale basis in pumped storage plants.

ABB - 125 years in hydropower

ABB has been developing technologies and providing solutions for the hydropower industry for more than 125 years – a legacy that goes back to the earliest days of ABB's history and its pioneering position in the development of the generation and distribution of electrical energy.

In that time ABB has supplied power and automation equipment for more than 300 hydropower plants all over the world, from small installations of one or two megawatts to huge hydroelectric power plants like Guri in Venezuela, which generates 10 gigawatts of electricity.

ABB supports its customers and their hydroelectric projects with a global network of hydropower centers of excellence and a worldwide presence in more than 100 countries.

Integrated instrumentation, control and electrical solutions

ABB is the world's leading supplier of just about every product in the power and automation scope of supply for hydropower plants – from generator circuit breakers and power transformers to switchgear, motors, drives and plant automation and protection systems.

This unique single-source capability enables ABB to provide complete and fully integrated instrumentation, control and electrical (ICE) solutions with a single user interface.

The benefits are numerous and substantial. They include reduced exposure to technical and commercial risk, the elimination of multi-vendor interfaces, and improved resource leveling. ABB integrated ICE solutions have shown time and again that they enable customers to save time, reduce costs and manage risk.

A single supplier for the plant's entire lifecycle

ABB's core competencies extend throughout the entire value chain and lifecycle of a hydropower plant.

They encompass plant engineering of the electrical, instrumentation and control systems and their integration into a seamless and optimized whole, as well as project management and the installation and commissioning of the entire ABB solution.

And when the project is completed and the plant up and running, ABB supports its customers with a comprehensive portfolio of lifecycle services that ranges from spare parts and equipment repair, to training, remote monitoring and technical support.

From products and systems to water-to-wire solutions

Alongside its integrated ICE solutions, ABB cooperates with leading manufacturers of turbines, generators and mechanical balance of plant to offer complete electro-mechanical packages for water-to-wire projects in hydropower plants of all sizes.

ABB offers its customers alternative packages of plant control and protection systems, electrical balance of plant, and turbine and generator components, as well as the market's most comprehensive range of power and automation products and systems.

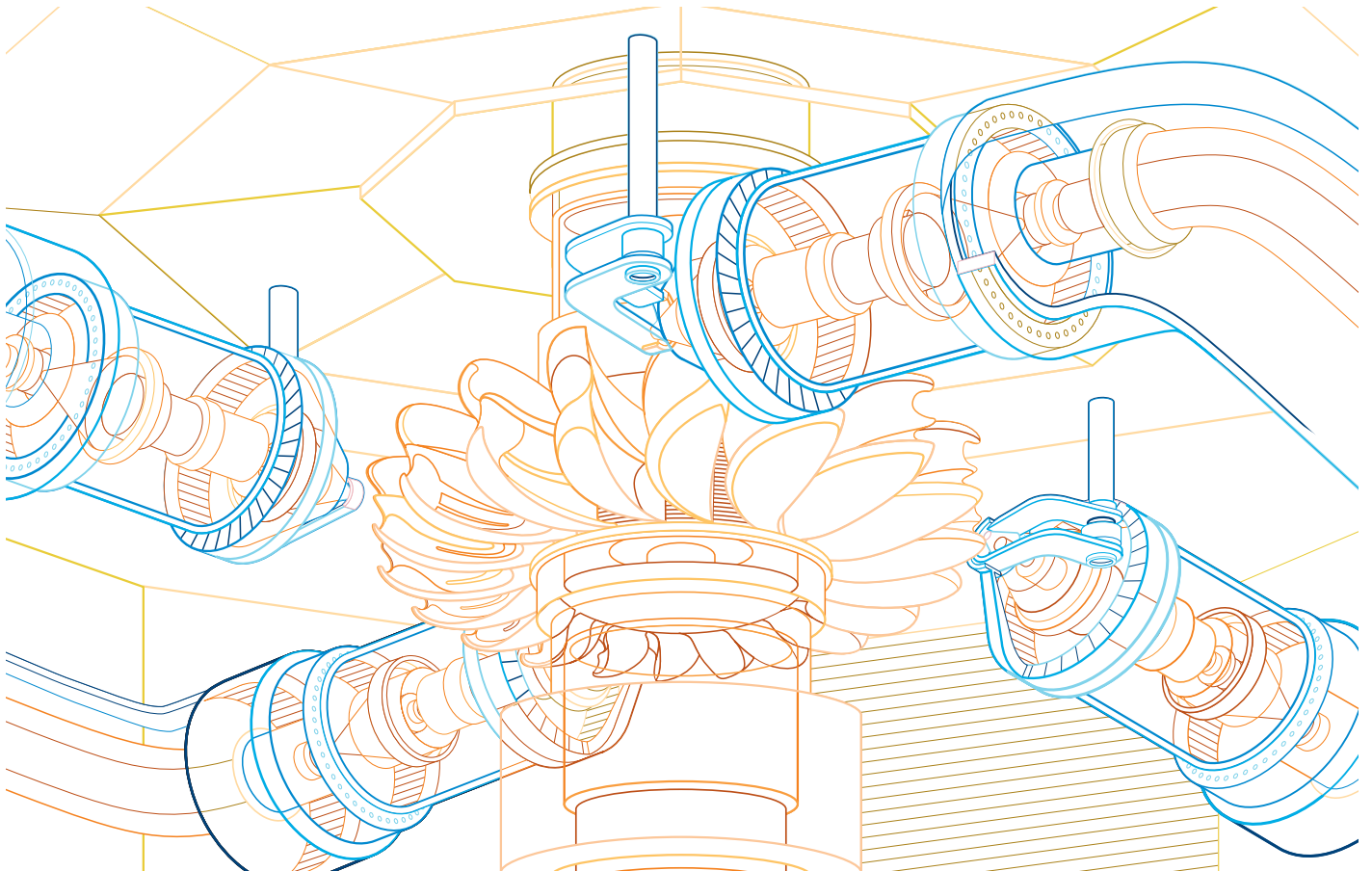

Power plant control and protection systems

ABB is a world-leading supplier of process automation systems. Our plant automation platform is the system of choice in a broad range of complex industrial processes like oil and gas, pulp and paper, cement, mining and power generation.

Designed to meet the most stringent requirements of all types of power generation, ABB's plant automation platform integrates the entire plant into a single control, engineering, operations and safety environment.

By providing plant-wide visibility and real-time information in a uniform way to the right people at the right time, our state-of-the-art technology brings measurable improvements to operator efficiency and plant performance.

Plant automation platform for power generation

ABB's control system for hydropower plants brings a number of performance-enhancing benefits to hydropower plants:

- It integrates the automation and electrical systems into a single control environment
- It supports the latest interface protocols like IEC 61850 and IEC 60870-5-103 and 104
- Its open architecture allows for the integration of a wide variety of third-party devices and systems, and its single platform simplifies the managing of assets to extend equipment life
- Its future-proof capability facilitates system evolution and protects previous investments in process graphics, control applications and historical data
- It is highly scalable – including different levels of redundancies - and eminently suitable for both the smallest and most complex of configurations in new and existing plants
- It offers a comprehensive suite of functionality at the plant control level, including OPC connectivity, mass data processing and self-sustaining redundancy, as well as all the usual functionalities like alarms, audit trail and trends
- And it integrates equipment protection systems for generator and transformer units, high-voltage switchgear, and medium- and low-voltage systems

Plant automation and SCADA systems

ABB solutions comprise all the systems required to successfully automate a hydropower plant. These modular and scalable systems manage the automation of the units, plant auxiliaries, substation, regulation of basins and hydraulic works, as well as speed/load control of the hydro turbines.

Whether it is for small hydro unit controls, run of the river hydro chain control or complex pumped storage applications, ABB solutions incorporate the following components and features:

- Unit control (turbine, generator, power transformer and unit auxiliaries)
- Plant control (common plant auxiliaries, HV switchyard, spillway, intake and other hydraulic systems)
- Complex control functions, such as joint control, cascade control, flood and river control, plant frequency control, reactive and active power control
- Remote control and dispatch center connectivity
- Integrated electrical and mechanical protection throughout the plant

Condition monitoring systems

ABB offers a wide range of products and solutions that monitor vibration and assess the condition of turbines and generators.

Analyst™ enables users to perform a graphical analysis of rotating machinery data. It presents historical vibration data and selected process variables graphically to machinery personnel so that significant patterns and trends can be quickly recognized.

1 and 2 Marchtrenk hydropower plant (Austria) - Unit control board and an AC800M control cubicle (interior)
3 Kops II (Austria) - Unit control board screenshot

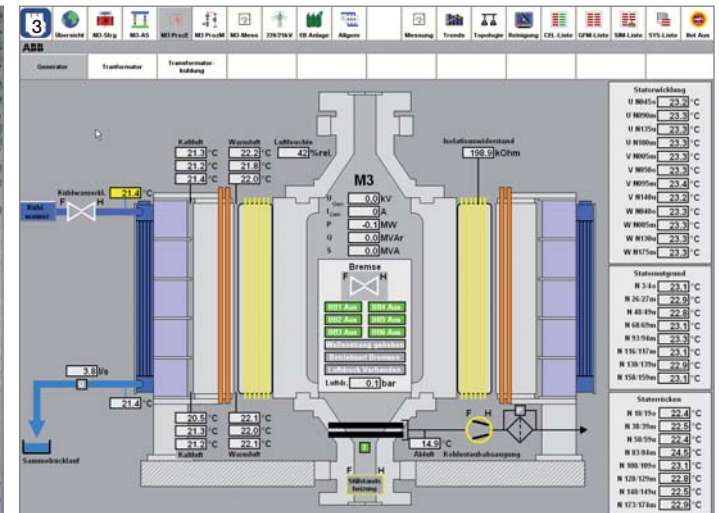
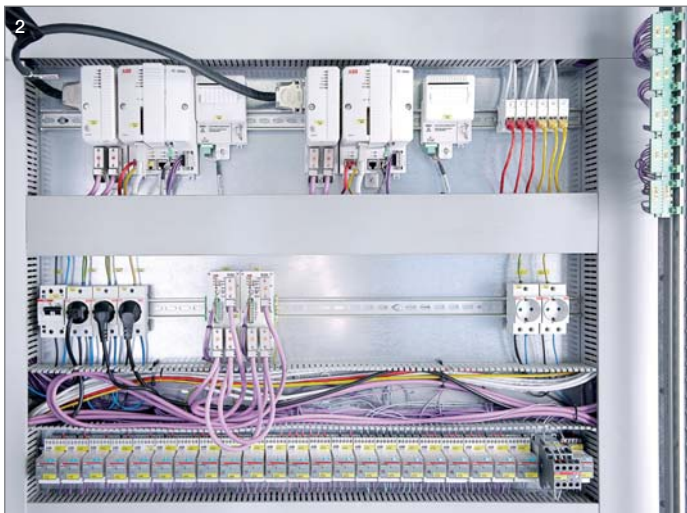

Electrical balance of plant

ABB's electrical balance of plant capability covers the entire power path, from the generator terminals to the high-voltage grid connection.

Our core competencies extend from plant engineering to project and site management, installation, commissioning, testing, and lifecycle maintenance and support.

This single-source capability in the electrical systems of a hydropower plant translates into a unique competency in delivering cost-effective solutions with the highest possible levels of equipment availability, reliability and safety.

Plant engineering and project management

ABB brings huge domain experience to each hydropower project. The ability to provide the most optimal solution for each site and successfully implement the project from start to finish is the hallmark of our eBoP offering.

We perform the site assessment, analyze the generation and transmission systems, provide the single line diagrams and carry out the short circuit and load calculations. We determine the component and cable sizing, and perform lightning and grounding calculations and the setting and selectivity calculations.

Benchmark performance with ABB solutions

Each ABB electrical balance of plant solution consists of 'Made in ABB' power products and systems that are invariably ranked the market and performance leaders in their product category.

- Grid connections

ABB provides generator busducts, generator circuit breakers, power transformers and high-voltage cables and switchgear that transfer the power safely and reliably to the grid.

About 70 percent of the world's generator circuit breakers are made by ABB. Recent ABB innovations have increased the performance of generator circuit breakers by more than 25 percent while simultaneously reducing the footprint, weight, noise levels and maintenance requirements of these essential components.



ABB has the largest portfolio of power and distribution transformers on the market and delivers about twice as many units a year as its nearest competitor. And in switchgear, ABB has pioneered major performance-enhancing technologies and delivered tens of thousands of gas- and air-insulated bays, including innovative hybrids that combine SF₆ circuit breakers with air-insulated switchgear.

- Medium- and low-voltage systems

ABB medium- and low-voltage systems consist entirely of ABB products – transformers, switchgear, variable speed drives, motors and generators.

As the market and technology leader in all product categories, ABB brings an unrivalled expertise in each technology and its integration into efficient and reliable medium- and low-voltage systems.

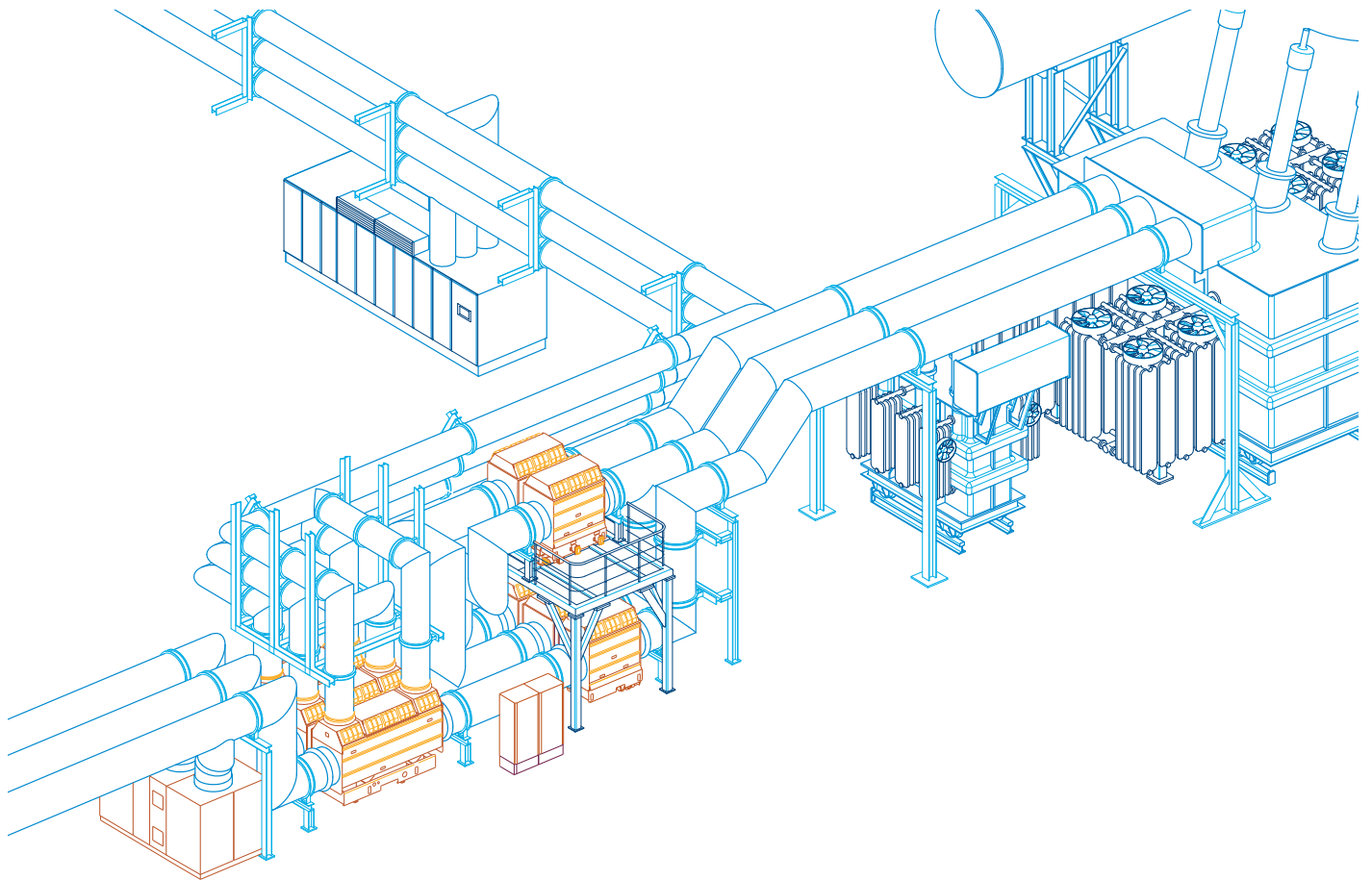
Our high-efficiency motors and variable speed drives bring energy-efficient speed control and soft-starting to plant equipment. And our air- and gas-insulated switchgear excels in safety, reliability and low lifecycle costs.

- Cables, emergency systems and facility management

ABB provides complete solutions for cable and tray systems, emergency backup systems and facilities management.

Our long and extensive experience of routing cable systems in complex industrial facilities and power plants ensures the shortest, safest and most reliable and effective solution for the thousands of kilometers of cables in a hydropower installation.

ABB also supplies complete emergency backup systems consisting of emergency and black start diesel generators and uninterruptible power supply systems, as well as all the necessary facility management systems for communications, lighting and power, fire detection and security.

ICE integration – the key to a successful project

ABB's ability to supply a complete and fully integrated instrumentation, control and electrical solution is the key to a successful project and the efficient and cost-effective operation of a hydropower plant.

Turbine and generator components

ABB has a long history of providing innovative solutions to ensure the safe, reliable and economic operation of turbines and generators.

Our intelligent hydro governors, high-performance excitation systems and pioneering static starter systems are recognized as among the most sophisticated on the market.

Built on decades of experience in turbine and generator technology, the solutions are geared to meet the performance requirements of hydropower plants of all capacities.

Intelligent solutions for hydro governors

ABB offers governor control solutions for a broad range of hydropower applications. The governors are fully integrated with our plant automation platform, and combine ABB's powerful AC800M controllers and hydropower governor library into a flexible, intelligent solution with customizable functionality.

Solutions include all the basic control functions and requirements like fast system response, high bandwidth, full compliance with IEEE and IEC standards for hydroelectric turbine governing, extensive system documentation, and operator and maintenance training.

The governor can run as a conventional stand-alone turbine governor or as a combined unit controller and turbine governor in a redundant or single controller.

1 Marchtrenk hydropower plant (Austria) | 2 High speed servo loop (scheme) | 3 Unintrol® 6000 | 4 Megadrive-LCI function blocks

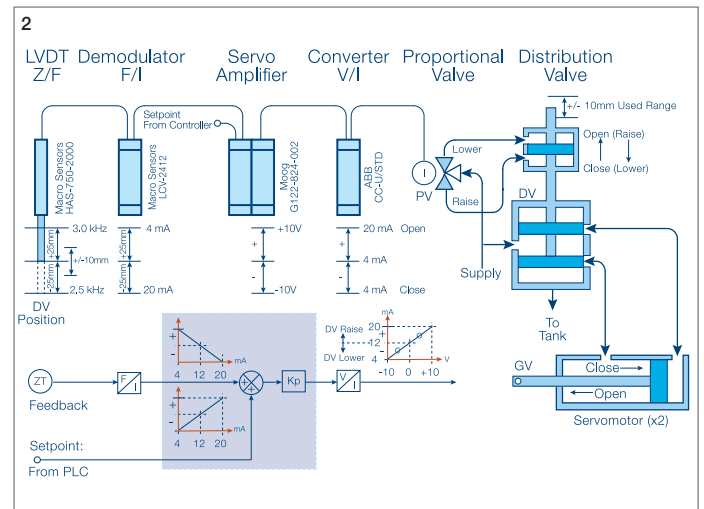

Excitation systems

ABB has been supplying excitation systems for more than 90 years. Our UNITROL® 6000 static excitation systems and automatic voltage regulators have set the benchmark for functionality, reliability and connectivity at hydropower plants all over the world.

The hardware and software components are fully integrated with ABB's plant automation system.

The controllers are based on ABB's AC 800PEC family of high-performance processors, which combine the high-speed control requirements of power electronics applications with low-speed process control tasks usually carried out by a separate PLC.

Standard UNITROL® 6000 software includes all the regulation, protection and monitoring functions necessary for the secure operation of the excitation systems, and is customizable to meet specific requirements.



Static Frequency Converter and AC Excitation Applications

A single static frequency converter (SFC), based on ABB's advanced power semiconductors, can be used to start several generator/motors, one after the other. The same SFC can also be applied for purging and slow turning during cooling. In pump storage hydropower plants this indispensable system ensures reliable start up and high availability of the turbine in pumping mode, lower investment costs compared to mechanical solutions, small footprint, easy maintenance requirements and limited wear and tear.

The introduction of advanced Voltage Source Inverter (VSI) technology in AC excitation systems for Doubly-fed Asynchronous Machines (DASM) in pump storage hydropower plants has been a major breakthrough in the application of variable speed units in pump storage hydropower plants. Thanks to the IGCT (VSI) technology used in ABB's AC excitation systems it was possible to reduce the costs and at the same time increase the performance of the variable speed technology. The flexibility given by this technology in respect of response to fluctuating grid conditions improves the overall economic performance of the power plant considerably.

Last but not least the application of frequency converters (FC) in connection with Permanent Magnet Generators (PMG) opens up new opportunities in the field of small to mini hydropower plants. The FC handles the control and protection of the generator without the need for separate protection, synchronization, excitation and circuit breaker equipment. Moreover reactive power control and compensation can be done even though the turbine is not running. With its cost saving potential this solution may turn projects, considered unprofitable with conventional technology, into profitable ones.

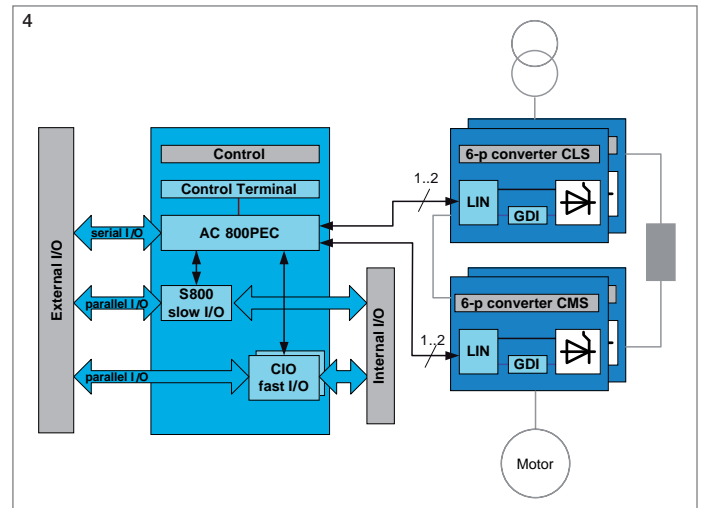

Lifecycle management for hydropower plants

ABB supports its customers with a complete portfolio of lifecycle services to ensure the efficient and cost-effective operation of their hydropower assets.

Our service portfolio is geared to provide customers with all the support they need across the entire field of lifecycle management, from troubleshooting, spare parts and equipment repair to training, remote monitoring and lifetime extension.

ABB service contracts are tailored to meet customer needs, are available all over the world, and are supported by a strong network of local service resources.

Evolution

New generations of software and system components increase operating efficiency and extend system life. ABB offers low-risk evolution strategies for a broad range of products and systems that are designed to ensure maximum return on investment while enhancing equipment availability and performance.

Upgrades and retrofits

ABB focuses on stepwise programs to upgrade existing systems and equipment, integrating installed and new system and control components to provide operational improvements.

Environmental services

ABB offers recycling solutions for decommissioned equipment and systems. ABB takes care of the proper disposal or recycling of installed or returned parts in compliance with all applicable regulations and requirements.

Training

ABB offers comprehensive training for engineers, operators, programmers and maintenance personnel, providing leading-edge technical expertise for products, processes and technology advances. Training is available at ABB training facilities worldwide, at your plant site or online.

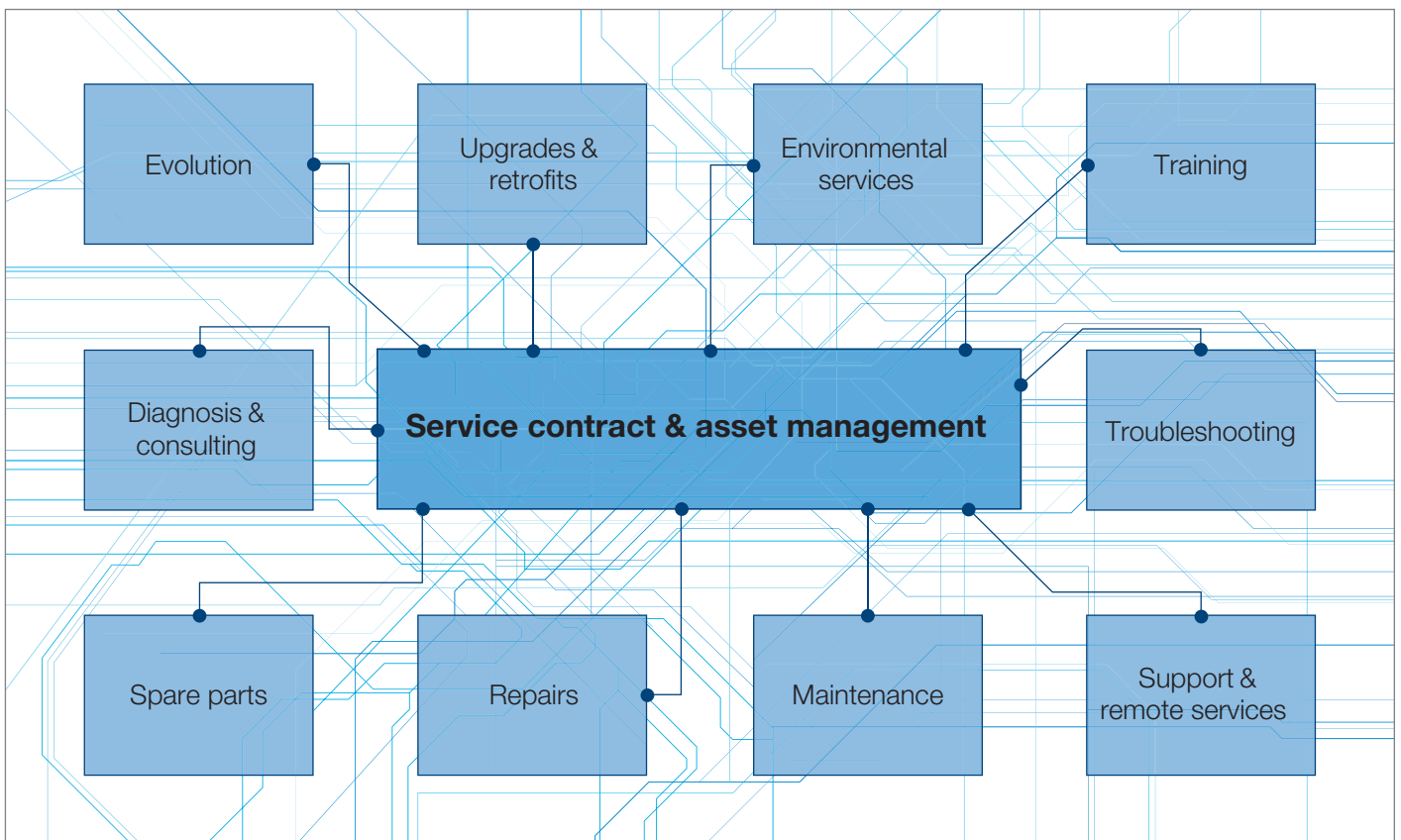

Troubleshooting

ABB service engineers are trained and certified to provide expert knowledge for root cause analysis and troubleshooting to bring the plant back to normal operation again.

Support and remote services

Remote services provide assistance for a wide range of support needs. From telephone and self-service web support, to direct and secure system interaction – we provide real-time, online access to global service experts 24 hours a day, seven days a week.

Maintenance

Effective preventive and corrective maintenance services improve the reliability of plant equipment. Our service technicians utilize the most advanced diagnostic and repair practices to maximize equipment performance and availability.

Repair

Reliable and efficient repair processing and logistics are key to efficient operations. Our repair services are ISO 9001 certified, provide timely repairs and advanced logistic services to satisfy specific customer needs.

Spare parts

Timely access to spare parts is essential for maintenance and plant availability - both bind working capital. ABB operates a global spare parts logistics system to minimize customers' capital investment and maximize plant utilization. Our spare parts web shop makes ordering both efficient and convenient.

Diagnosis and consulting

ABB experts have a profound knowledge of global best practices in a wide range of business and engineering operations. We develop and implement service solutions based on industry-specific technologies and competencies to help customers improve overall equipment effectiveness and return on investment.

Asset management

ABB provides lifecycle assessments of critical plant equipment, including component reliability calculation analysis. Our assessments equip power generators with the information required to make cost-effective, long-term decisions on overall system operation and maintenance. ABB service contracts guarantee that our experts are only a phone call away.



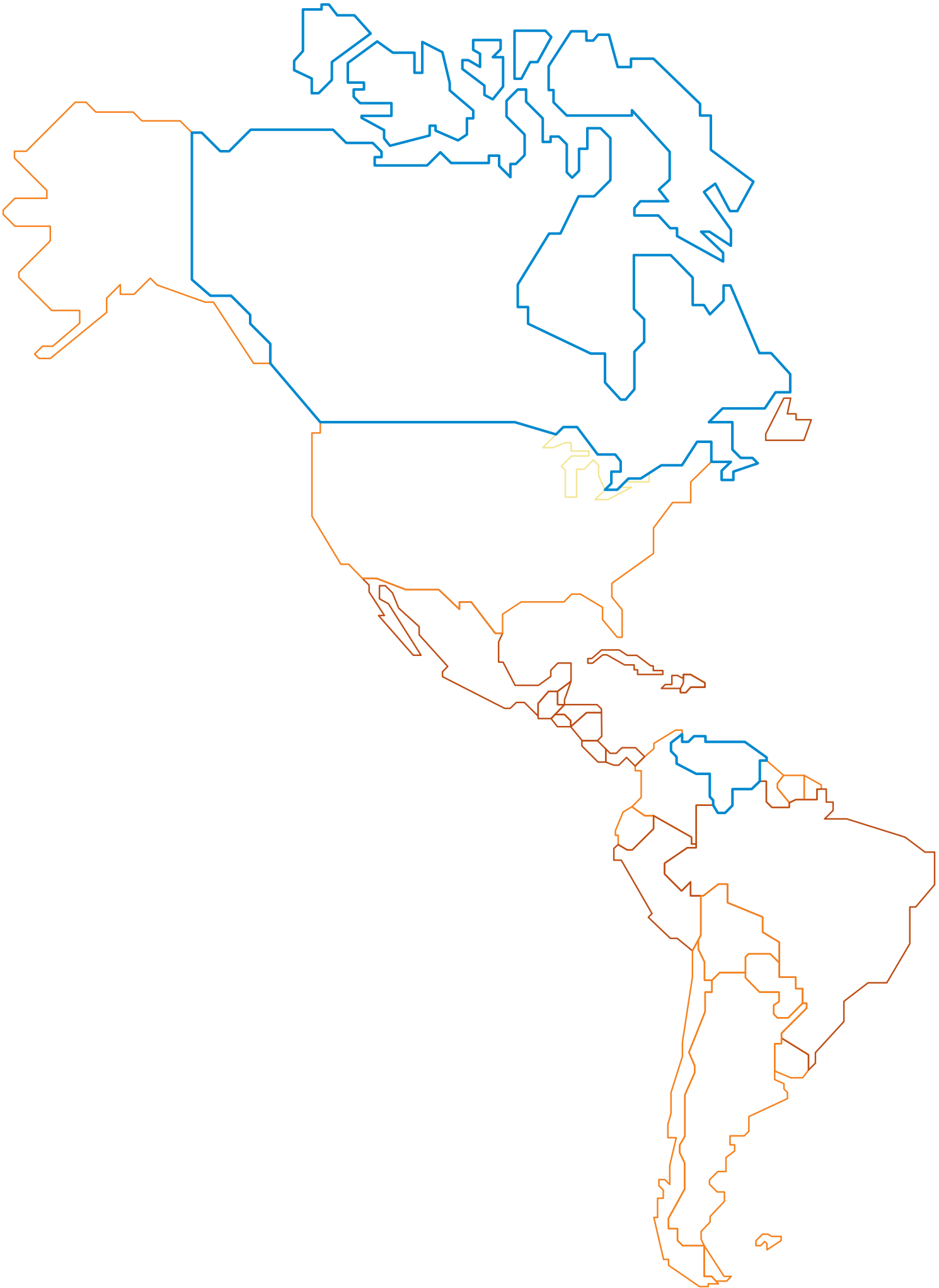

Helping our customers achieve their targets

ABB has supplied solutions for more than 300 hydropower plants all over the world.

Our solutions cover a broad spectrum of customer requirements – from extending plant operating life, to improving plant efficiency and safety, to modernizing or integrating plant instrumentation, control and electrical systems, to enabling power generators to comply with important regional power transmission requirements.

In all instances, the ABB solutions have met or exceeded customer targets and requirements.

EBoP retrofit for 2,730 MW hydropower plant: G.M. Shrum generating station, Canada

Customer: BC Hydro

Commissioning: 2009-2011

Customer needs

- Improve the availability and safety of the plant electrical and control systems

ABB solution

Turnkey solution for complete station service system – plant controls, auxiliary systems, battery systems, fire systems and cabling

Customer benefits

- Safety incorporated into the design solution
- Complete ABB scope of supply, from system studies to commissioning and training

Modernizing the world's third largest hydropower plant: Guri 10 GW, Venezuela

Customer: Electrificación del Caroní C.A. (EDELCA)

Commissioned: 2009

Customer needs

- Modernize the 20 generating units of a 10 GW hydropower plant, the third largest in the world

ABB solution

- Turnkey ICE packages for each of the 20 generating units
 - Instrumentation and unit control systems
 - Electrical protection and communication
 - Modernization of the plant's three high-voltage switchyards

Customer benefits

- Plant operating life extended by an estimated 30 years
- Plant availability improved
- Complete ICE solution from a single supplier

Helping our customers achieve their targets

Integrating two hydropower plants with ENTSO-E: Ataturk 8x300 MW and Karakaya 6x300 MW, Turkey

Customer: Electricity Generation Corporation Management (EUAS)

Commissioned: 2008-2009

Customer needs

- Integrate the plants with the European Network of Transmission System Operators for Electricity (ENTSO-E)

ABB solution

- Modernization of the plant control systems to System 800xA for Power Generation, with remote access
- Modernization of the turbine governors and excitation systems, replacement of the generator protection and other electrical equipment

Customer benefits

- Compliance with ENTSO-E requirements

Extending the life of a hydropower plant: Trebinje 2x60 MW + 70 MW, Bosnia and Herzegovina

Customer: Elektroprivreda Republika Srpska (EPRS)

Commissioned: 2003

Customer needs

- Extend the life of the plant and improve plant efficiency and availability

ABB solution

- Integrated instrumentation, control and electrical solution based on System 800xA for Power Generation
- Modernization of excitation, synchronization and UPS systems

Customer benefits

- Efficient and reliable operation secured for another 30 years
- Improving staff expertise through extensive ABB training

Fast peak response time for pumped storage plant: Kops II 3x150 MW, Austria

Customer: Vorarlberger Illwerke AG

Commissioned: 2008

Customer needs

- New pumped storage plant for peak load production

ABB solution

- System 800xA for Power Generation plant control system
- Generator busducts, 220 kV gas-insulated switchgear and 400 kV auxiliary switchgear

Customer benefits

- Fast response to peak demand and unscheduled power flows in the European grid system

Remote-controlled pumped storage plant in China: Yixing 4x250 MW, Jiangsu province, China

EPC partner: General Electric

Commissioned: 2007

Customer needs

- Electro-mechanical package for 4x250 MW pumped storage power plant

ABB solution

- Control and protection systems
- EBoP including MV switchgear, generator circuit breaker, isolated phase bus, excitation systems, static frequency converter, cabling, 500 kV gas-insulated switchgear and LV switchgear

Customer benefits

- Completely automated solution with remote control from two dispatch centers
- Fully integrated control, protection and electrical system



Helping our customers achieve their targets

Building a new 200 MW unit and a step towards new control technology: PSW Vianden, 9 x 100 + 1 x 196 + 1 x 200 MW, Luxembourg

Customer: SEO, Luxembourg
Commissioning: 2013 (ABB)

Customer needs

- Control & electrical protection for a new 200 MW unit, extension of existing SCADA system with up-to-date technology
- high availability and reliability

ABB solution

- Unit control based on AC 800M (next generation to existing Advant system) and extension/upgrade of System 800xA for Power Generation based SCADA system
- IEC 61850 LAN for connection of electrical protection, voltage regulation and synchronization equipment
- redundancies of controllers, operating stations, servers and LAN, high integrity I/O components

Customer benefit

- Connectivity to existing control/SCADA system and first step in to next generation technology of AC 800M/800xA that may replace the existing Advant/System 800xA for Power Generation in due time

Emergency repair of a hydropower unit severely damaged by fire: Rodund II, 1 x 295 MW, Austria

Customer: Vorarlberger Illwerke AG (VIW)
Commissioning: 2011

Customer needs

- Repair of the damaged unit in the shortest possible time, with uprating and modernization of adjacent components and control/SCADA system

ABB solution

- Generator bus duct (IPB)
- System 800xA for Power Generation plant control system

Customer benefits

- The upgrading of the control system provides not only a more efficient operation of this plant but also a seamless integration in to the customer's network, linking the customer's hydropower plants in the region

Fit for green certificate - Narni, 2 x 25 MW, Italy

Customer: E.On
Commissioned: 2010

Customer needs

- Complete revamping for Green Certificate, improve reliability and availability

ABB solution

- Delivery of AC 800M based control system with single controllers and PGP (Power Generation Portal), REG670 protections, excitation system Unitrol U6080, synchronization SYNC5
- Electrical balance of plant

Customer benefit

- Turbine efficiency ($\eta > 93\%$)
- Green Certification
- Technology improvement

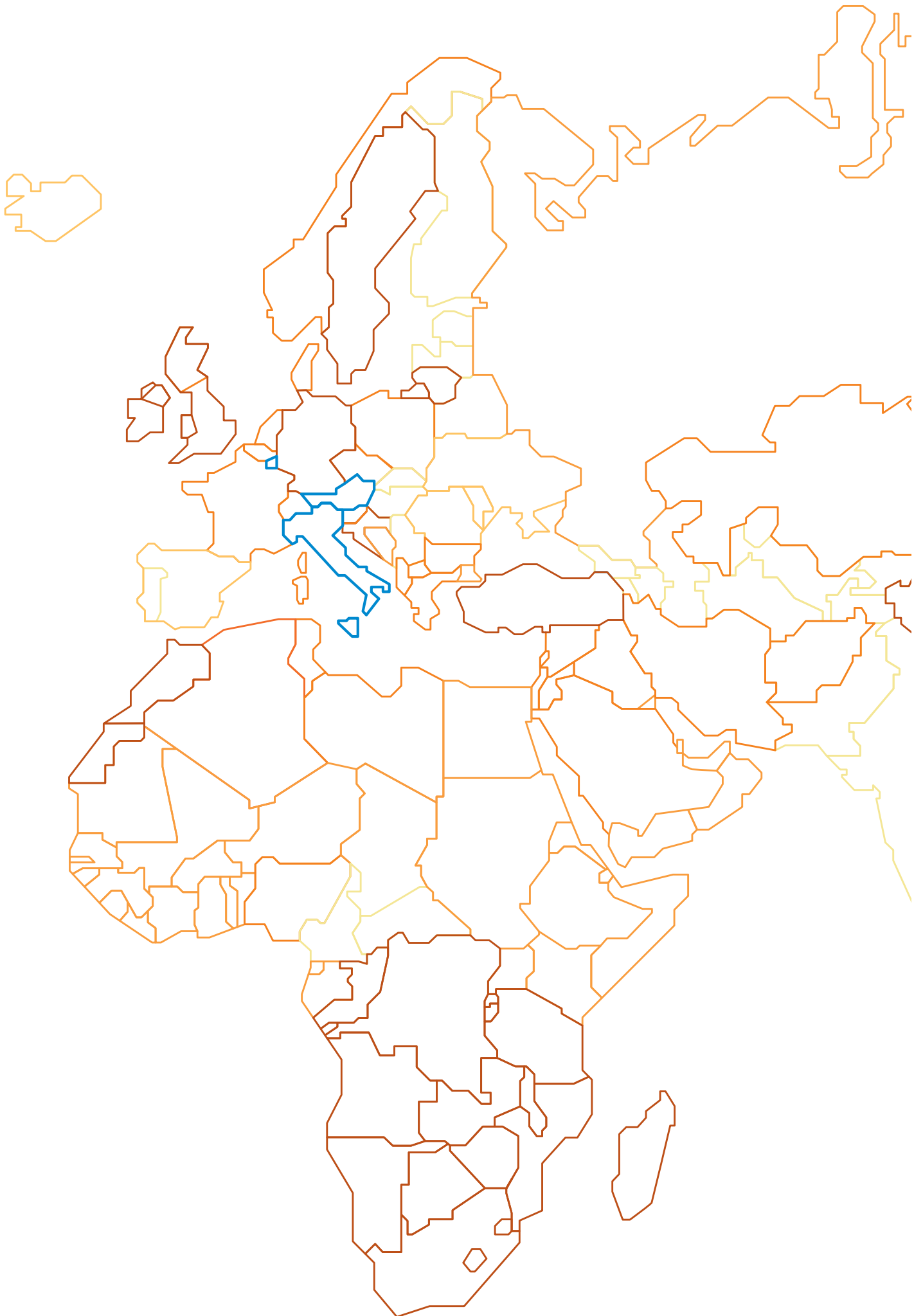

Contact us

ABB Ltd.

Business Unit Power Generation

P.O. Box 8131

8050 Zurich, Switzerland

Phone: +41 (0) 43 317-5380

Fax: +41 (0) 43 317-5382

www.abb.com/powergeneration