



Sizing and Selection

- Piston Accumulators
- Bladder Accumulators
- KleenVent



Accumulator Sizing For:

- Shock Suppression
- Thermal Expansion
- Pulsation Dampening
- Auxiliary Power Source

Sizing and Selection Software

Parker offers leading edge application assistance, in the form of the **inPHorm™** Accumulator Sizing and Selection Software (see page 16).

For manual sizing calculations, see below and on the following pages.

For further engineering assistance, contact Parker's Accumulator Technical Support Group at (815) 636-4100.



Accumulator Sizing for:

- Shock Suppression
- Thermal Expansion
- Pulsation Dampening
- Auxiliary Power Source

Calculations for accumulator sizing take into consideration the charge and discharge rate of the accumulator.

Auxiliary Power Source

$$V_1 = \frac{V_w \left(\frac{P_3}{P_1} \right)^{1/f}}{0.95 \left[1 - \left(\frac{P_3}{P_2} \right)^{1/n} \right]}$$

Where:

- P_2 = Maximum operating pressure in PSIA
- P_3 = Minimum operating pressure in PSIA
- P_1 = Pre-charge pressure required in PSIA
- V_w = Volume of fluid collected or discharged by accumulator, In³
- V_1 = Required Accumulator volume, In³
- f = Nitrogen gas constant-charging of Accumulators (see charts on pages 134-135)
- n = Nitrogen gas constant-discharging of Accumulators (see charts on pages 134-135)

Note: Gas Precharge usually 100 psi below minimum pressure for **Piston Accumulators***.
 Gas precharge is 90% of minimum pressure for **Bladder Accumulators**.

*90% where minimum system pressure is less than 1000 psi.

Hydraulic line shock suppression

$$V_1 = \frac{(12W) (V^2) (n-1) \left(\frac{P_2}{P_1}\right)^{1/n}}{2 (g) (P_2) \left[\left(\frac{P_m}{P_2}\right)^{(n-1)/n} - 1 \right]} + (Q * 1.155)$$

Where:

- W = weight of fluid (lbs)
- V = fluid velocity (ft/sec)
- n = Discharge coefficient ([see charts on pages 134-135](#))
- P₂ = system pressure
- P_m = Shock pressure
- V₁ = accumulator size required
- P₁ = pre-charge pressure
- G = force of gravity
- Q = flow rate in GPM

Thermal Expansion

$$V_1 = \frac{V_a (T_2 - T_1) (\beta - 3\alpha) \left(\frac{P_2}{P_1}\right)^{1/n}}{1 - \left(\frac{P_2}{P_3}\right)^{1/n}}$$

Where:

- α = Coefficient of Linear Expansion of Pipe Material per °F
- β = Coefficient of Cubical Expansion of Fluid per °F
- n = Discharge Coefficient (see charts on pages 134-135)
- P₁ = Precharge
- P₂ = Minimum System Pressure @ T₁ (PSIA)
- P₃ = Maximum System Pressure @ T₂ (PSIA)
- V₁ = Accumulator Size
- V_a = Fluid Volume Subject to Thermal Expansion
- T₁ = Initial Temperature (Lower Temp °Kelvin)
- T₂ = Final Temperature (Higher Temp °Kelvin)

**Coefficient of Linear
Expansion of Pipe
Material per °F**

Steel: 6.33 x 10-6
 Cast Iron: 6.55 x 10-6
 Aluminum: 10 x 10-6

**Coefficient of Cubical
Expansion of Fluid per °F**

Water: 1.15 x 10-4
 Oil: 4.60 x 10-4

Piston pump pulsation dampening

$$V_1 = \frac{ALK \left(\frac{P_2}{P_1} \right)^{1/n}}{1 - \left(\frac{P_2}{P_3} \right)^{1/n}}$$

Where:

- K = Pump output coefficient
- n = Coefficient of discharge (see charts on pages 134-135)
- P₁ = Nitrogen gas pre-charge
- P₂ = System operating pressure
- P₃ = Maximum allowable shock pressure
- A = Piston area
- L = Piston stroke
- V₁ = Accumulator size required

Pump output coefficient is calculated depending on single acting or double acting pump:

| | |
|-------------------|-----|
| Simplex single | .60 |
| Simplex double | .25 |
| Duplex single | .25 |
| Duplex double | .15 |
| Triplex single | .13 |
| Triplex double | .06 |
| Quadruplex single | .10 |
| Quadruplex double | .06 |
| Quintiplex single | .06 |
| Quintiplex double | .02 |

Existing accumulator output used in an auxiliary power source application.

Calculations for accumulator sizing takes into consideration the charge and discharge rate of the accumulator.

$$V_w = \frac{0.95 V_1 \left[1 - \left(\frac{P_3}{P_2} \right)^{1/n} \right]}{\left(\frac{P_3}{P_1} \right)^{1/f}}$$

Where:

- P₂ = Maximum operating pressure in PSIA
- P₃ = Minimum operating pressure in PSIA
- P₁ = Pre-charge pressure required in PSIA
- V_w = Volume of fluid collected or discharged by accumulator, In³
- V₁ = Required Accumulator volume, In³
- f = Nitrogen gas constant-charging of Accumulators (see charts on pages 134-135)
- n = Nitrogen gas constant-discharging of Accumulators (see charts on pages 134-135)

Note: Gas Precharge usually 100 psi below minimum pressure for **Piston Accumulators**.
 Gas precharge is 90% of minimum pressure for **Bladder Accumulators**.

Temperature Variation

Temperature variation can seriously affect the precharge pressure of an accumulator. As the temperature increases, the precharge pressure increases; conversely, decreasing temperature will decrease the precharge pressure. In order to assure the accuracy of your accumulator precharge pressure, you need to factor in the temperature variation. The temperature variation factor is determined by the temperature encountered during precharge versus the operating temperature expected in the system.

Temperature During Precharge

| | 30. | 40. | 50. | 60. | 70. | 80. | 90. | 100. | 110. | 120. | 130. | 140. | 150. | 160. | 170. | 180. | 190. | 200. | 210. | 220. |
|------|------|------|------|------|------|------|------|------|------|------|------|------|------|------|------|------|------|------|------|------|
| 30. | 1.00 | 1.02 | 1.04 | 1.06 | 1.08 | 1.10 | 1.12 | 1.14 | 1.16 | 1.18 | 1.20 | 1.22 | 1.24 | 1.27 | 1.29 | 1.31 | 1.33 | 1.35 | 1.37 | 1.39 |
| 40. | .98 | 1.00 | 1.02 | 1.04 | 1.06 | 1.08 | 1.10 | 1.12 | 1.14 | 1.16 | 1.18 | 1.20 | 1.22 | 1.24 | 1.26 | 1.28 | 1.30 | 1.32 | 1.34 | 1.36 |
| 50. | .94 | .98 | 1.00 | 1.02 | 1.04 | 1.06 | 1.08 | 1.10 | 1.12 | 1.14 | 1.16 | 1.18 | 1.20 | 1.22 | 1.24 | 1.25 | 1.27 | 1.29 | 1.31 | 1.33 |
| 60. | .92 | .94 | .98 | 1.00 | 1.02 | 1.04 | 1.06 | 1.08 | 1.10 | 1.12 | 1.13 | 1.15 | 1.17 | 1.19 | 1.21 | 1.23 | 1.25 | 1.27 | 1.29 | 1.31 |
| 70. | .92 | .94 | .96 | .98 | 1.00 | 1.02 | 1.04 | 1.06 | 1.08 | 1.09 | 1.11 | 1.13 | 1.15 | 1.17 | 1.19 | 1.21 | 1.23 | 1.25 | 1.26 | 1.28 |
| 80. | .91 | .93 | .94 | .96 | .98 | 1.00 | 1.02 | 1.04 | 1.06 | 1.07 | 1.09 | 1.11 | 1.13 | 1.15 | 1.17 | 1.19 | 1.20 | 1.22 | 1.24 | 1.25 |
| 90. | .89 | .91 | .93 | .95 | .96 | .98 | 1.00 | 1.02 | 1.04 | 1.05 | 1.07 | 1.09 | 1.11 | 1.13 | 1.15 | 1.16 | 1.18 | 1.20 | 1.22 | 1.24 |
| 100. | .88 | .89 | .91 | .93 | .95 | .96 | .98 | 1.00 | 1.02 | 1.04 | 1.05 | 1.07 | 1.09 | 1.11 | 1.13 | 1.14 | 1.16 | 1.18 | 1.20 | 1.21 |
| 110. | .86 | .88 | .89 | .91 | .93 | .95 | .96 | .98 | 1.00 | 1.02 | 1.04 | 1.05 | 1.07 | 1.09 | 1.11 | 1.12 | 1.14 | 1.16 | 1.18 | 1.19 |
| 120. | .84 | .86 | .88 | .90 | .91 | .93 | .95 | .97 | .98 | 1.00 | 1.02 | 1.03 | 1.05 | 1.07 | 1.09 | 1.10 | 1.12 | 1.14 | 1.16 | 1.17 |
| 130. | .83 | .85 | .86 | .88 | .90 | .92 | .93 | .95 | .97 | .98 | 1.00 | 1.02 | 1.03 | 1.05 | 1.07 | 1.08 | 1.10 | 1.12 | 1.14 | 1.15 |
| 140. | .82 | .83 | .85 | .87 | .88 | .90 | .92 | .93 | .95 | .97 | .98 | 1.00 | 1.02 | 1.03 | 1.05 | 1.07 | 1.08 | 1.10 | 1.12 | 1.13 |
| 150. | .80 | .82 | .84 | .85 | .87 | .89 | .90 | .92 | .93 | .95 | .97 | .98 | 1.00 | 1.02 | 1.03 | 1.05 | 1.07 | 1.08 | 1.10 | 1.11 |
| 160. | .79 | .81 | .82 | .84 | .85 | .87 | .89 | .90 | .92 | .94 | .95 | .97 | .98 | 1.00 | 1.02 | 1.03 | 1.05 | 1.06 | 1.08 | 1.10 |
| 170. | .78 | .79 | .81 | .83 | .84 | .86 | .87 | .89 | .90 | .92 | .94 | .95 | .97 | .98 | 1.00 | 1.02 | 1.03 | 1.05 | 1.06 | 1.08 |
| 180. | .77 | .78 | .80 | .81 | .83 | .84 | .86 | .88 | .89 | .91 | .92 | .94 | .95 | .97 | .98 | 1.00 | 1.02 | 1.03 | 1.05 | 1.06 |
| 190. | .75 | .77 | .78 | .80 | .82 | .83 | .85 | .86 | .88 | .89 | .91 | .92 | .94 | .95 | .97 | .98 | 1.00 | 1.02 | 1.03 | 1.05 |
| 200. | .74 | .76 | .77 | .79 | .80 | .82 | .83 | .85 | .86 | .88 | .89 | .91 | .92 | .94 | .95 | .97 | .98 | 1.00 | 1.02 | 1.03 |
| 210. | .73 | .75 | .76 | .78 | .79 | .81 | .82 | .84 | .85 | .87 | .88 | .90 | .91 | .93 | .94 | .96 | .97 | .99 | 1.00 | 1.01 |
| 220. | .72 | .74 | .75 | .76 | .78 | .79 | .81 | .82 | .84 | .85 | .87 | .88 | .90 | .91 | .93 | .94 | .96 | .97 | .99 | 1.00 |

Let's assume the temperature during precharge is 70°F, the expected operating temperature is 130°F, and your desired precharge is 1000 psi. Find the charging temperature of 70°F in the top horizontal row. Next, find the operating temperature of 130°F in the left hand, vertical column. Extend lines from each value until they intersect to find the temperature variation factor; in this case, 0.90. Multiply the desired precharge of 1000 psi by the temperature variation factor of 0.90 to obtain the actual precharge pressure required – 900 psi.

**Selection Chart for Charge Coefficient "f"
 & Discharge Coefficient "n" Chart No. 1**

0 - 8 Seconds

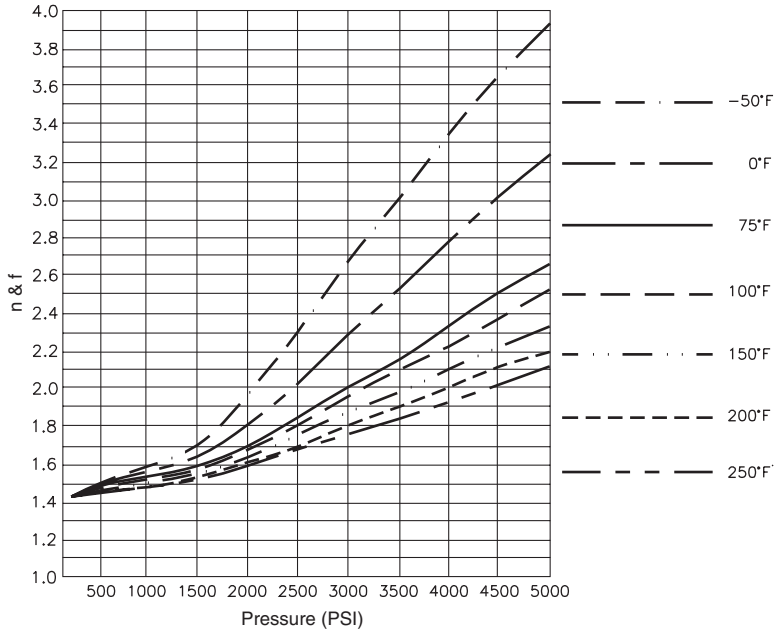

9 - 30 Seconds

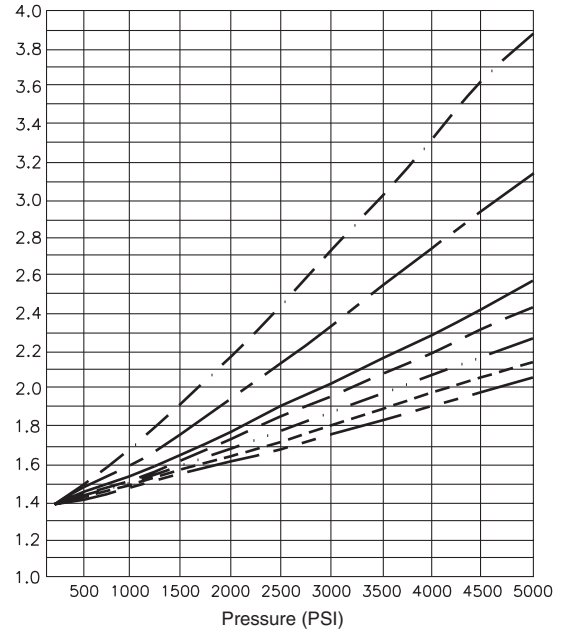

31 - 60 Seconds

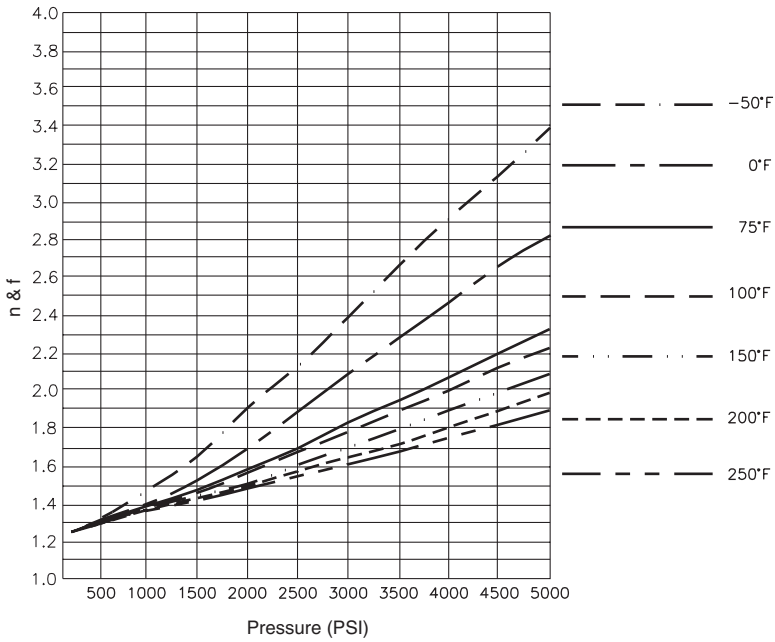

61 - 120 Seconds

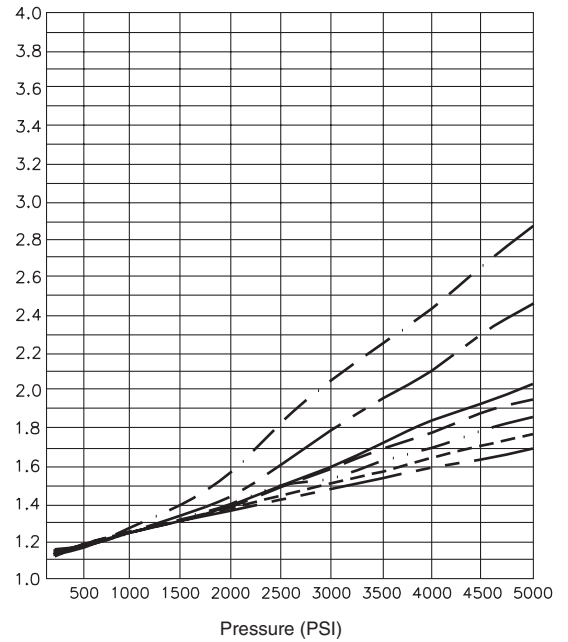

Selection Chart for Charge Coefficient “f” & Discharge Coefficient “n” Chart No. 1

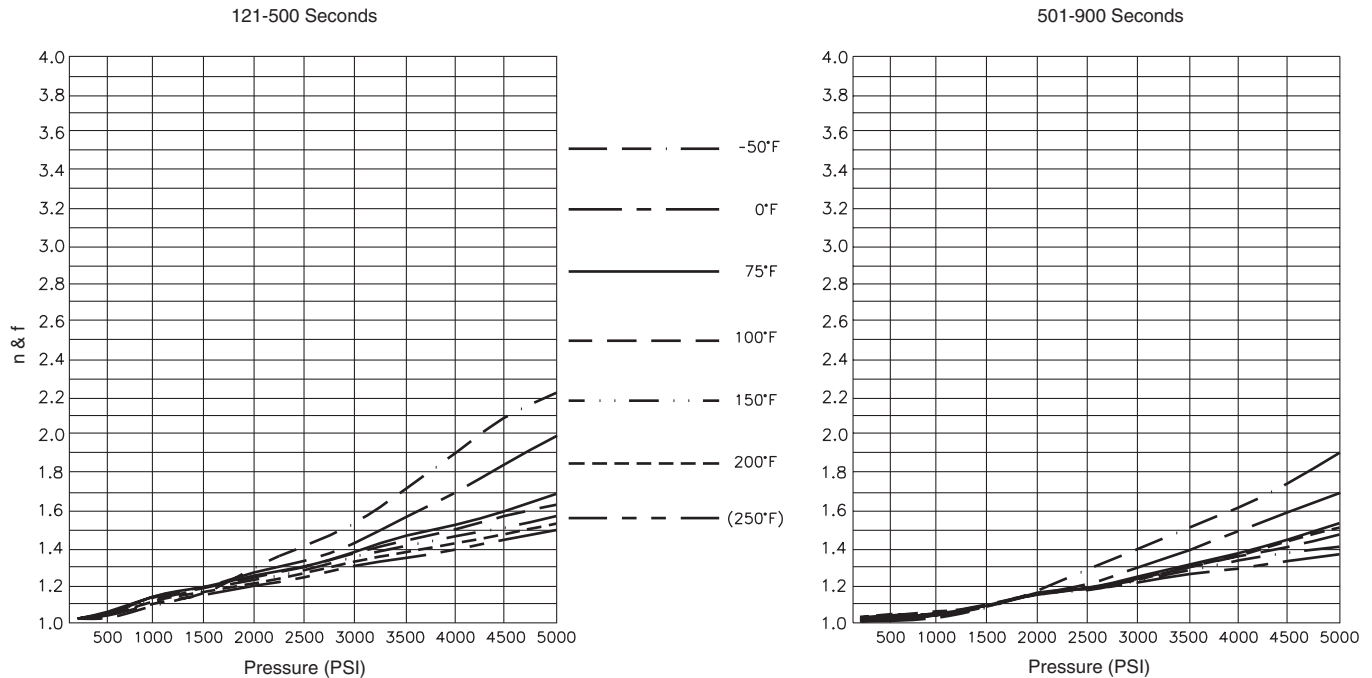

Instructions for selection of Charge Coefficient “f” & Discharge Coefficient “n”

1. Determine Average System Pressure.
2. Determine the time required in seconds to charge the accumulator with fluid.
3. Determine the time in seconds to discharge the oil from the accumulator.
4. Select the graph which corresponds to the time (seconds) required to charge (discharge) the accumulator with fluid.
5. Select the curve on the graph which corresponds to the gas operating temperature. (If gas temperature under operating conditions is not known, assume 100°F.)
6. To use the graph, locate the average system pressure along the bottom portion of the graph. Move vertically along this column until you intersect the line corresponding to the gas temperature. Then move horizontally along this line, read the charge coefficient “f” on the left side of the graph. “f” = Charge Coefficient.
7. Repeat for the discharge coefficient “n” starting with Step #4. “n” = Discharge Coefficient.

Applications

***Safety Note:**

In any accumulator circuit, a means should be available of automatically unloading the accumulator when the machine is shut down. Such a valve could be located at this point in the circuit.

Control of Usable Volume

The usable volume of an accumulator should be discharged at a controlled rate. If an accumulator is required to maintain system pressure, this controlled rate is automatically achieved by the leakage fluid it has to replace. However, an accumulator which is used to develop a pressurized flow can discharge its usable volume too rapidly as a downstream directional valve is shifted. For this reason, accumulators in this application are often equipped with a flow control and bypass check at their inlet-outlet port.

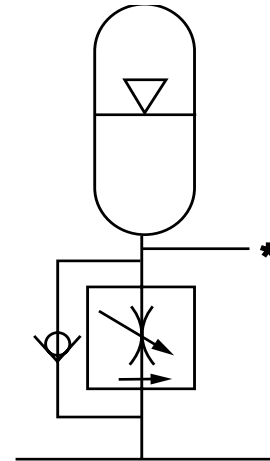

Pump Unloading in Accumulator Circuits

To keep a pump/electric motor fully unloaded until it is required to re-charge an accumulator, an electric pressure switch can be used.

In the circuit illustrated, a pressure switch senses accumulator pressure sending and cutting-out electrical signals at various pressure levels. The electrical signals are transmitted to a normally-open, solenoid operated 2-way valve which vents and de-vents a pilot operated relief valve. When the accumulator is being charged, the pressure switch sends an electrical signal to the 2-way valve solenoid. With the accumulator charged, the pressure switch cuts out the signal, venting the relief valve and unloading pump/electric motor. The setting of the pressure switch determines the pressure range within which a pump/electric motor works.

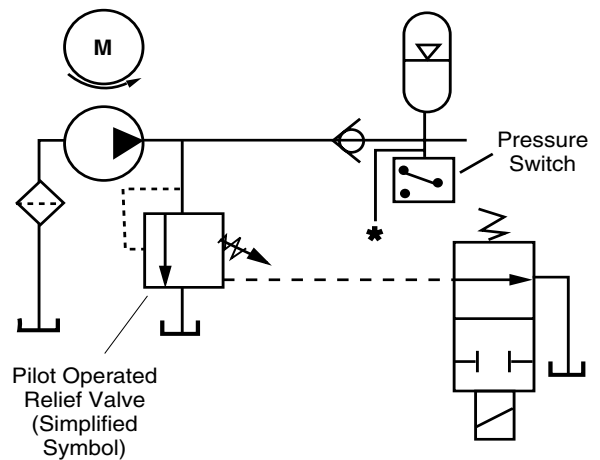

Using a pressure switch to vent a relief valve results in a pump/electric motor being fully unloaded when system conditions dictate.

In the circuit illustrated, an unloading valve is used to dump a flow back to tank once an accumulator is charged to the unloading valve setting.

Once the valve closes, pump/electric motor must therefore generate power to recharge the accumulator to the unloading valve setting.

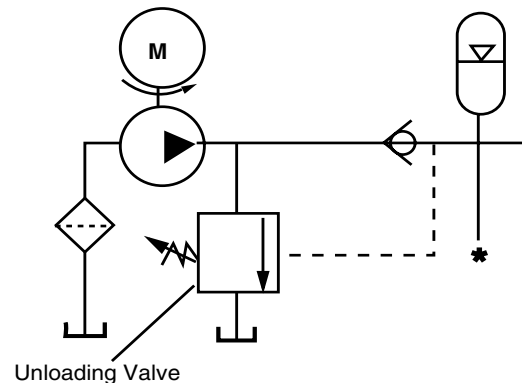

Applications

Differential Unloading Relief Valve

Instead of using a pressure switch and solenoid valve to vent a relief valve while an accumulator is charged, one hydraulic component can be used — a differential unloading relief valve.

A differential unloading relief valve is specifically designed for use with accumulators. As its name implies, the valve unloads a pump/electric motor over a differential pressure range.

A differential unloading relief valve consists of a pilot operated relief valve, check valve, and differential piston in one valve body. The valve body includes pump, tank, and accumulator passages.

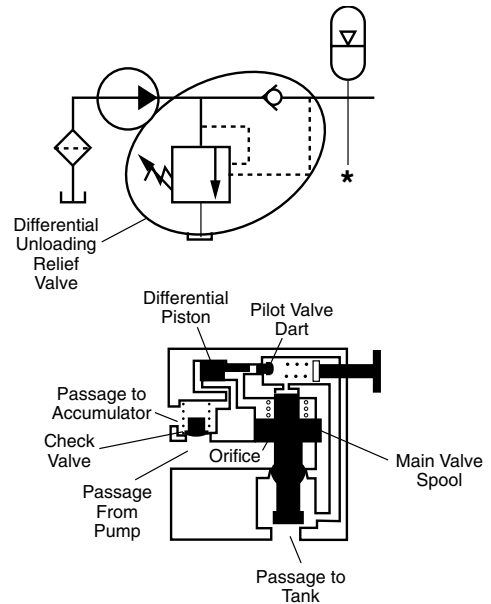

Maintaining Pressure

Accumulators are used to maintain pressure. This can be required in one leg of a circuit while pump/electric motor is delivering flow to another portion of the system.

In the circuit illustrated, two clamp cylinders are required to hold a part in place. As the directional valves are shifted, both cylinders extend the clamp at the pump's compensator setting. During this time, the accumulator is charged to the setting also.

System demands require that cylinder B maintain pressure while cylinder A retracts. As directional valve A is shifted, pressure at the pump, as well as in line A, drops quite low. Pressure at cylinder B is maintained because the accumulator has stored sufficient fluid under pressure to make up for any leakage in line B.

Accumulators not only maintain pressure by compensating for pressure loss due to leakage, but they also compensate for pressure increase due to thermal fluid expansion or external mechanical forces acting on a cylinder.

In the illustrated circuit, assume that the cylinder is operating near a furnace where ambient temperatures are quite high. This causes the fluid to expand. With an accumulator in the circuit, the excess volume is taken up, keeping the pressure relatively constant. Without an accumulator, pressure in the line would rise uncontrollably and may cause a component housing, fitting, or conductor to crack.

The same situation can also occur if an external mechanical force acts to retract the cylinder. Assume now that the cylinder is clamping a curing press. As curing occurs, heat within the press causes it to expand resulting in a force acting to retract the piston rod. The accumulator once again absorbs the additional volume, maintaining the pressure at a relatively constant level.

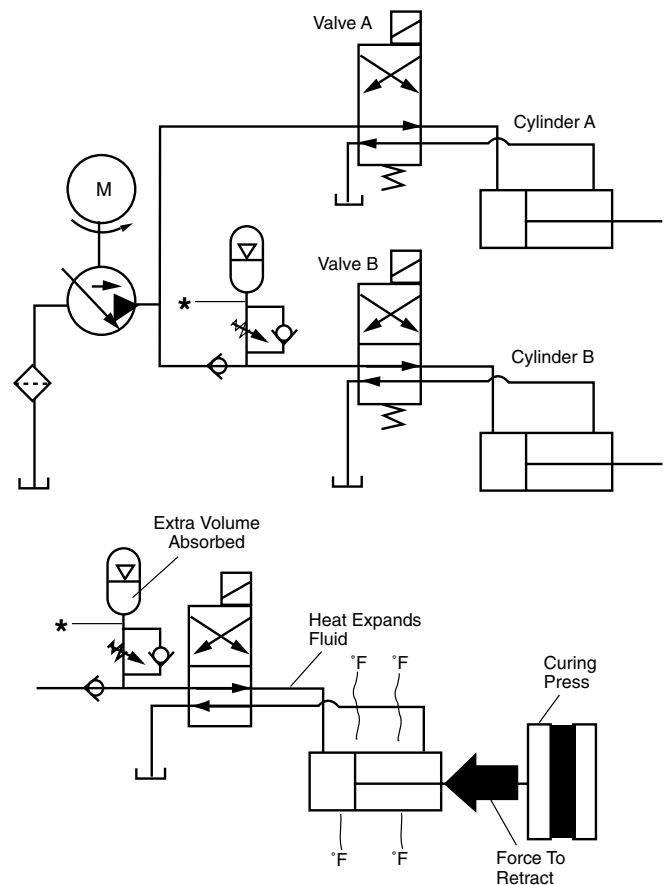

***Safety Note:**

In any accumulator circuit, a means should be available for automatically unloading the accumulator when the machine is shut down. Such a valve could be located at this point in the circuit.

Developing Flow

Since charged accumulators are a source of hydraulic potential energy, stored energy of an accumulator can be used to develop system flow when system demand is greater than pump delivery. For instance, if a machine is designed to cycle infrequently, a small displacement pump can be used to fill an accumulator over a period of time. When the moment arrives for the machine to operate, a directional valve is shifted downstream, and the accumulator delivers the required pressurized flow to an actuator.

Using an accumulator in combination with a small pump in this manner conserves peak horsepower. For instead of using a large pump/electric motor to generate a large horsepower all at once, the work can be evenly spread over a time period with a small pump/electric motor.

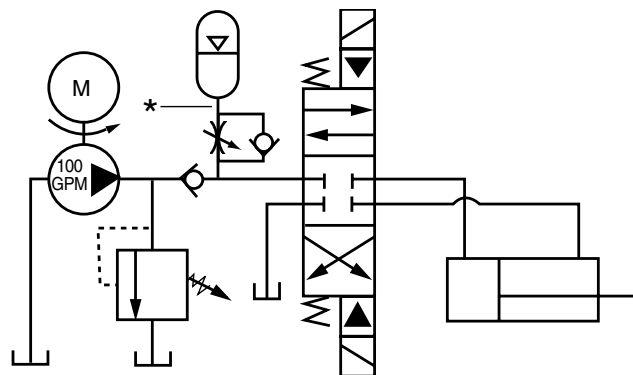

Absorbing Shock

Hydro-pneumatic accumulators are sometimes used to absorb system shock even though in this application they are difficult to properly design into a system.

Shock in a hydraulic system may be developed from the inertia of a load attached to a cylinder or motor. Or, it may be caused by fluid inertia when system flow is suddenly blocked or changed direction as a directional valve is shifted quickly. An accumulator in the circuit will absorb some of the shock and not allow it to be transmitted fully throughout the system.

Shock may also occur in a hydraulic system due to external mechanical forces. In the circuit illustrated, the load attached to the cylinder has a tendency to bounce causing the rod to be pushed in and shock generated. An accumulator positioned in the cylinder line can help reduce the shock effects.

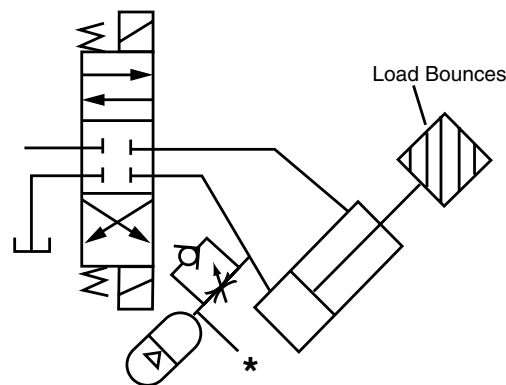

***Safety Note:**

In any accumulator circuit, a means should be available for automatically unloading the accumulator when the machine is shut down. Such a valve could be located at this point in the circuit.

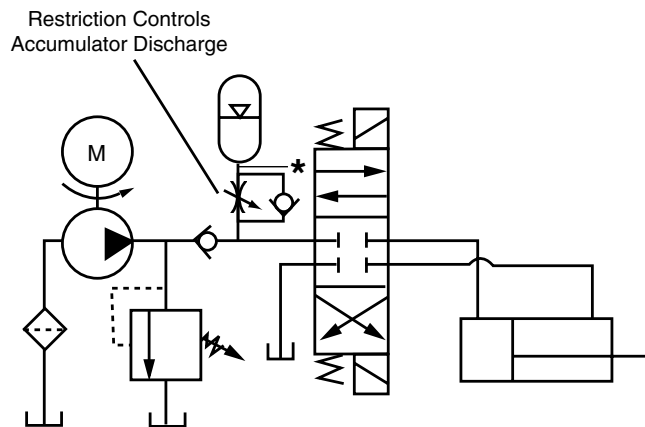

Developing System Flow

Contact Information

CUSTOMER:

ADDRESS: _____

CONTACT: _____

PHONE: _____

FAX: _____

EMAIL: _____

Customer Requirements

Quantity/Release: _____

Quantity (Annual): _____

Type (Piston or Bladder): _____

Bore Size (piston only): _____

Capacity: _____

Working Pressure/Design Factor: _____

Seal Type/Compound: _____

Hydraulic Port: _____

Gas Port: _____

Operating Temperature Range: _____

System Fluid: _____

Gas Valve: _____

Precharge: _____

Water Service? _____

Plating/Coating: _____

Material Type: _____

Paint: _____

Switches: _____

Certification: _____

Special Test? _____

Special Label? _____

Customer Drawing Included? _____

Customer Part # _____

Envelope Restrictions: _____

Application Description/Comments

*Please fill out and fax to 815-636-4113.
For assistance, call 815-636-4100.*



