

Bent axis hydraulic motors

MA
Series

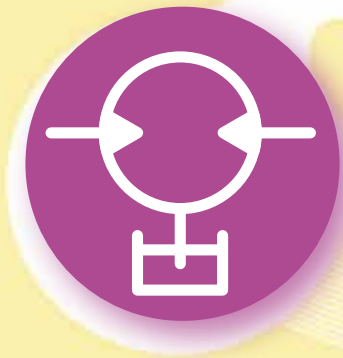
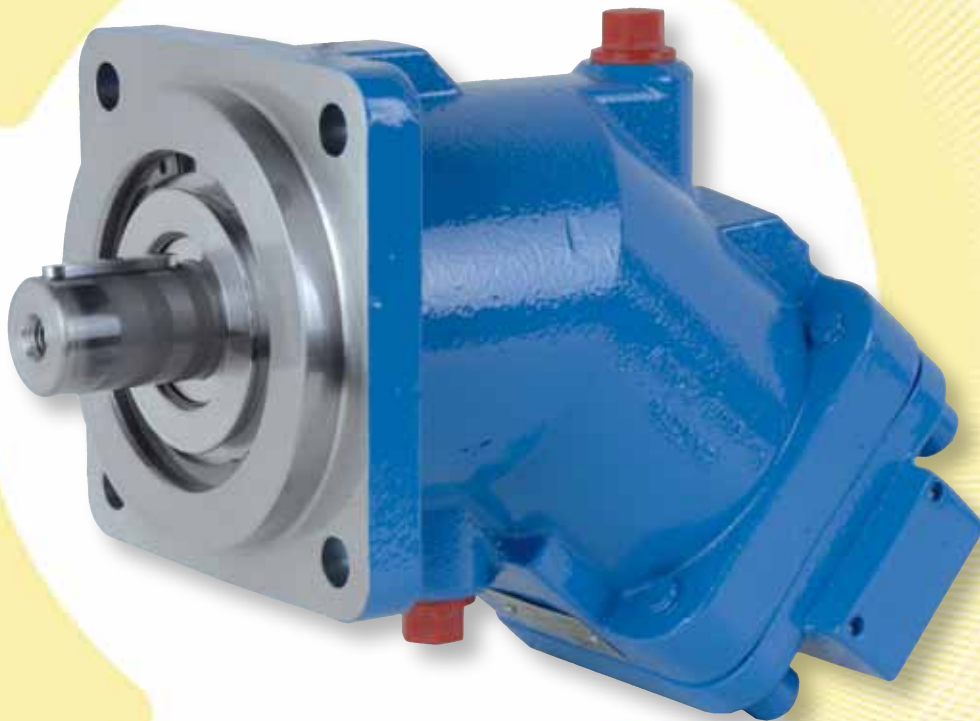

 **HYDRO
LEDUC**

Contents

MA series motors

■ Definition and main applications of hydraulic motors, advantages of LEDUC motors	1
■ Operating conditions of motors	2
■ Determining the right motor	3
■ Range and characteristics	4
■ Efficiency curves	5
■ Order code system	6
■ Dimensions	7 - 17
■ Flushing valve - Speed sensor	18
■ ATEX certification	19
■ Installation and start-up recommendations	20
■ Other LEDUC product lines	21

LEDUC hydraulic motors of the MA series are of bent axis design, with an angle of 40°. They combine high performance and reduced size envelope:

- global efficiency of over 90% (guaranteed in most applications);
- suitable for use at operating speeds between 50 and 8,000 rpm;
- optimized weight and size.

Available in displacements from 12 cc to 125 cc, MA motors are suitable for all the main fixed and mobile applications. They are designed for use in either closed or open loop systems. To ensure the best service life from your motors, please take care to follow the installation and start-up recommendations (see pages 2 and 19).



HYDRO LEDUC also manufactures a range of semi-integrated (plug-in) motors: the MSI series. Literature on request or on our website : www.hydroleduc.com



HYDRO LEDUC
Head Office & Factory
BP 9
F-54122 AZERAILLES (FRANCE)
Tél. +33 (0)3 83 76 77 40
Fax +33 (0)3 83 75 21 58

Advantages of MA series motors

■ Definition of function

Hydraulic motors transform hydraulic flow into rotating speed and hydraulic pressure into mechanical torque.
Motor rotating speed is proportional to the flow which is supplied to it.
Torque produced is proportional to the hydraulic pressure the motor receives.

■ Main applications of hydraulic motors

Typical applications are those requiring high torque within a small size.
The hydraulic motor is essential for rotations where:

- mechanical solutions are complex or even impossible,
- electrical or pneumatic power sources are not available,
- environments are dangerous (i.e. risk of explosion or extreme temperatures).

■ Advantages of LEDUC motors

All structural components are made from similar materials resulting in consistent thermal expansion and exceptional reliability.

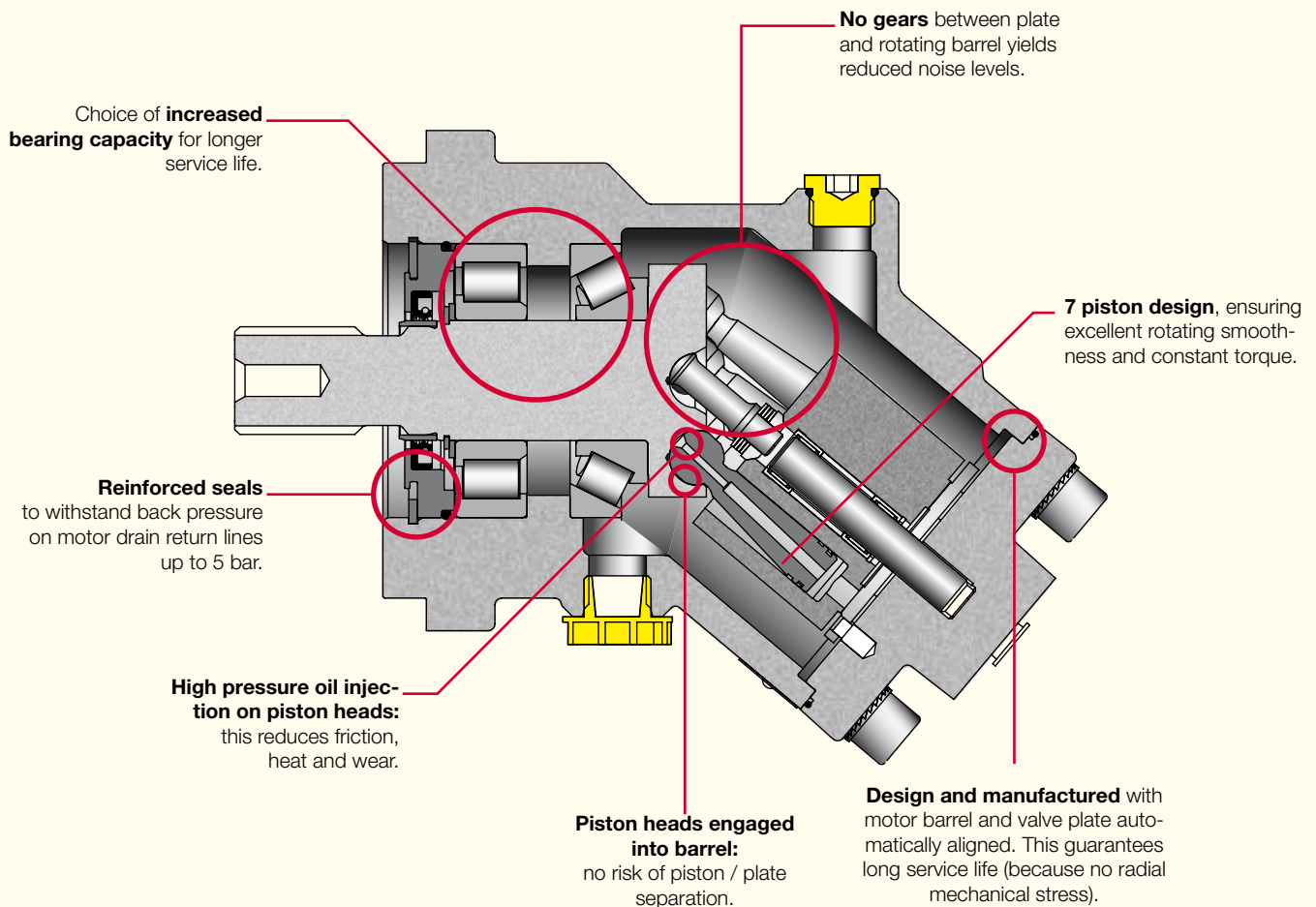

Operating conditions of MA series motors

Hydraulic fluid

LEDUC motors are designed to be powered with mineral based hydraulic fluid. Using other fluids is possible but may require a modified motor. Please contact us with details of fluid.

Recommended viscosity:

- Ideally : between 15 and 200 cSt;
- Maximum range: between 5 and 1600 cSt.

Filtration of hydraulic fluid

The service life of the motors depends greatly on the quality and the cleanliness of the hydraulic fluid.

We recommend minimum cleanliness as follows:

- NAS 1638 class 9
- SAE class 6
- ISO/DIS 4406 class 18/15

Direction of rotation

The motors rotate clockwise or counter-clockwise depending on the direction of hydraulic flow entering the motor.

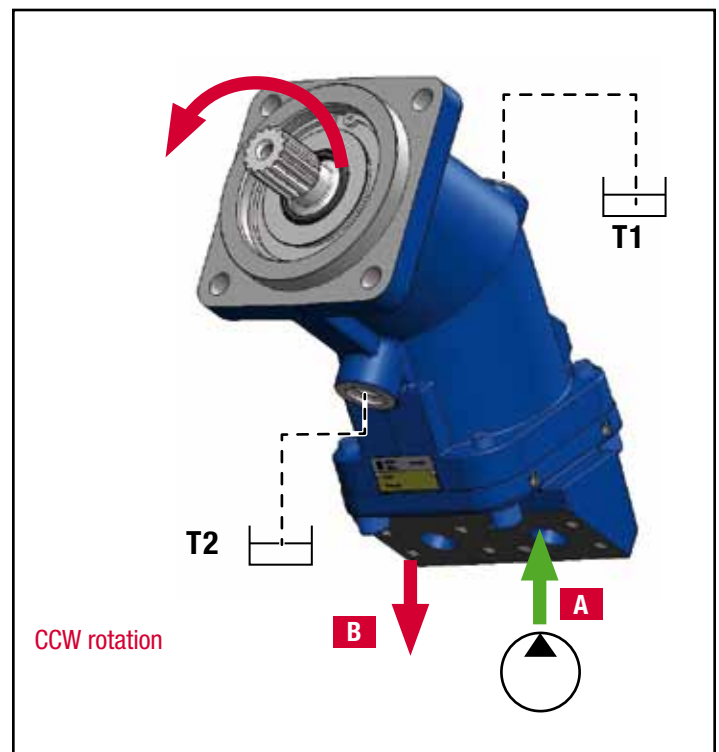
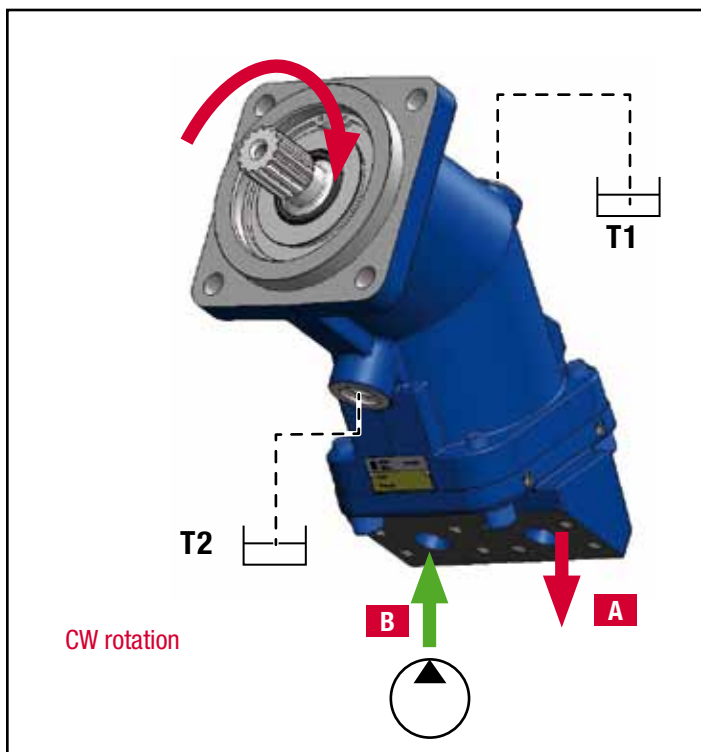

Drain pressure

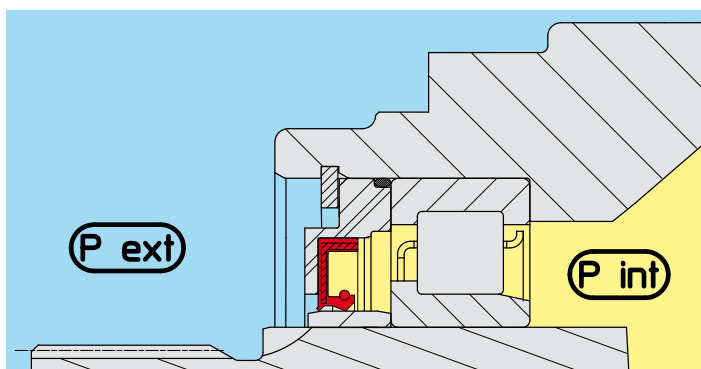

It is essential to drain the motor, T1 or T2, to avoid excessive pressures on the shaft seal.

Maximum acceptable internal pressure depends on motor rotating speed.

However, following these guidelines will avoid problems during operation:

- maximum internal pressure (**P int**) regardless of rotating speed (continuous): 4 bar (60psi);
- maximum internal pressure (**P int**) regardless of rotating speed (peak): 5.5 bar (80psi);
- minimum pressure in the motor housing: must be greater than ambient (external) pressure (**P ext**).

Determination MA series motors

How to determine the correct motor for your application

Calculations:

- N = rotating speed (rpm)
- C = torque (in.lbs)
- P = pressure supplied by the hydraulic pump in (psi)
- ΔP = pressure difference between A and B in (psi)
- Disp. = displacement (in^3/rev)
- Q = flow (gpm)
- E = efficiency (%)

1. Torque supplied by the hydraulic motor

Theoretical torque $T_{th} = (\Delta P \times \text{Disp}) / 2\pi$

Actual torque = $T = T_{th} \times E$

For example a 3.07 in^3/rev motor with a ΔP of 3.625 psi will supply a theoretical torque of 1770 in.lbs
 Average global efficiency of the motor is 90% , actual torque is: 1.594 in.lbs

2. Rotating speed of the motor

The rotating speed of the hydraulic motor depends on the flow Q which goes through it, and on the displacement of the motor.

$N = (Q \times 231 \text{ in}^3/\text{gal}) / \text{Disp}$

test bench for motors



Example

- ① Motor
- ② Variable displacement pump
- ③ Pressure relief valve
- ④ Valve
- ⑤ Hydraulic motor
- ⑥ Winch and load

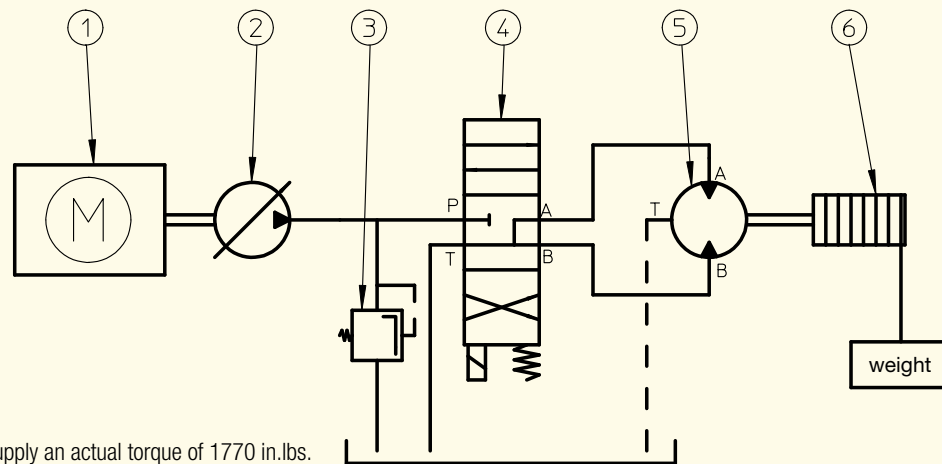

The receiving organ (winch) ⑥ needs to rotate at $N = 400$ rpm and supply an actual torque of 1770 in.lbs.

The hydraulic pump ① is capable of operating at pressure P up to 5075 psi.

1. Calculating the displacement of the hydraulic motor:

$\text{Disp} = (T_{th} \times 2\pi) / \Delta P$ thus **Disp = 2.19 in^3**

In the LEDUC range, choose a motor with a displacement of **1.95 in^3** or **2.5 in^3** .

2. Calculating the flow Q which the pump needs to supply:

$Q = (N \times \text{Disp}) / 231 \text{ in}^3/\text{gal}$ thus **Q = 3.79 gpm**

Corresponding flow :
 - for **1.95 in^3** motor, Q = 3.38 gpm
 - for **2.5 in^3** motor, Q = 4.33 gpm

Range and characteristics MA series motors

Characteristics of the MA series motors

MA series motors are suitable for intensive long duty requirements. Designed for both mobile and industrial installations.

Typical applications are:

- vehicle transmissions;
- high power crushers;
- forestry equipment;
- heavy duty winches...

These motors are built to suit all applications with SAE (J744) mounting configurations.

* For wider extreme temperatures, please contact us.

(1) for higher speeds, please contact us.

For special fluids, please contact us.

Displacement		continuous max. speed ⁽¹⁾	Intermittent max. speed ⁽¹⁾	Max. flow absorbed		Torque		Torque at 5100 psi (350 bar)		Motor max./min. temperature*	Max. allowable pressure continuous/peak	weight	
Cu.In	cc	(rpm)	(rpm)	gpm	(l/mn)	lbf.ft/psi	m.N/bar	lbf ft	m.N	°F (°C)	psi (bar)	lbs	kg
0.73	12	8000	8800	25.4	96	0.0096	0.19	49	66	-13/230 (-25/110)	5800/6525 (400/450)	12	5.5
1.1	18	8000	8800	38.1	144	0.0143	0.28	73	98	-13/230 (-25/110)	5800/6525 (400/450)	12	5.5
1.52	25	6300	6900	41.8	158	0.0204	0.4	104	140	-13/230 (-25/110)	5800/6525 (400/450)	25	11.5
1.95	32	6300	6900	53.5	202	0.0253	0.5	129	175	-13/230 (-25/110)	5800/6525 (400/450)	25	11.5
2.78	45	5000	5500	59.5	225	0.0359	0.65	183	248	-13/230 (-25/110)	5800/6525 (400/450)	40	18
2.50	41	5600	6200	60.8	230	0.0359	0.65	167	227	-13/230 (-25/110)	5800/6525 (400/450)	25	11.5
3.07	50.3	5000	5500	66.7	252	0.0406	0.8	207	280	-13/230 (-25/110)	5800/6525 (400/450)	40	18
3.84	63	5000	5500	83.3	315	0.0508	1	259	350	-13/230 (-25/110)	5800/6525 (400/450)	40	18
4.90	80.4	4500	5000	95.8	362	0.0645	1.27	329	445	-13/230 (-25/110)	5800/6525 (400/450)	51	23
5.49	90	4500	5000	100	378	0.0720	1.42	367	497	-13/230 (-25/110)	5800/6525 (400/450)	51	23
6.61	108.3	3400	4500	96.95	367	0.0862	1.70	439	595	-13/230 (-25/110)	5800/6525 (400/450)	77	35
7.65	125.4	3400	4500	112.54	426	0.1004	1.99	513	695	-13/230 (-25/110)	5800/6525 (400/450)	77	35

Acceptable forces applied to motor shaft

Fr : radial force measured at mid point of length of shaft.

Fa : axial force which tends to push the shaft inwards.

Displacement	Cu.In	0.73	1.1	1.52	1.95	2.50	2.78	3.07	3.84	4.90	5.49	6.61	7.65
	cc	12	18	25	32	41	45	50	63	80	90	108.3	125.4
Fr	lbf	630	900	1350	1462.5	1574	900	900	1125	1462.5	1507.5	2812	3262
	N	2800	4000	6000	6500	7000	4000	4000	5000	6500	6700	12500	14500
Fa	lbf / psi	0.23	0.31	0.42	0.46	0.62	0.62	0.62	0.77	0.93	1.03	1.24	1.33
	N/psi* (N/bar)	1.03 (15)	1.37 (20)	1.86 (27)	2.06 (30)	2.75 (40)	2.75 (40)	2.75 (40)	3.44 (50)	4.14 (60)	4.62 (67)	5.52 (80)	5.93 (86)

* differential pressure between A and B. For other forces, please contact us.

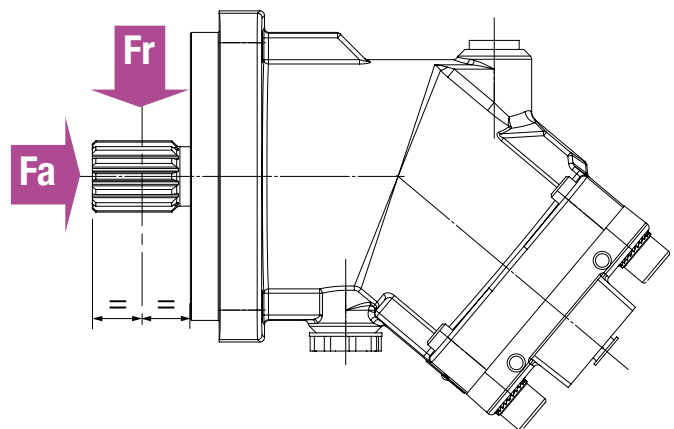

Efficiency MA series motors

■ Efficiency of motors $f(\text{displacement})$

N of motor = 1000 rpm
ISO46 fluid at 25°C

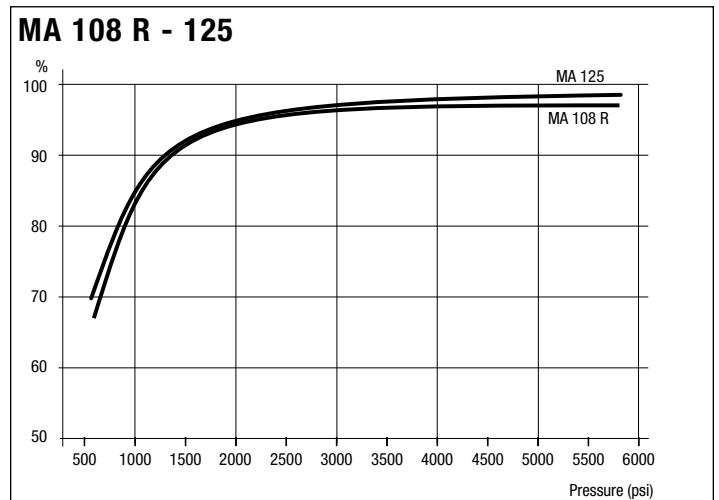
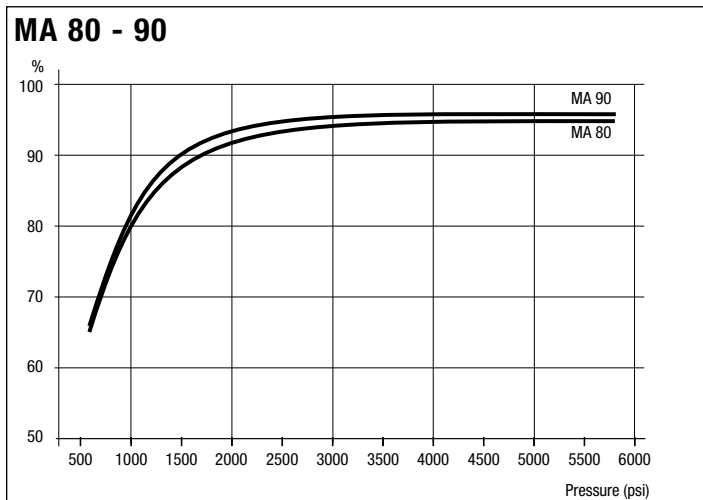
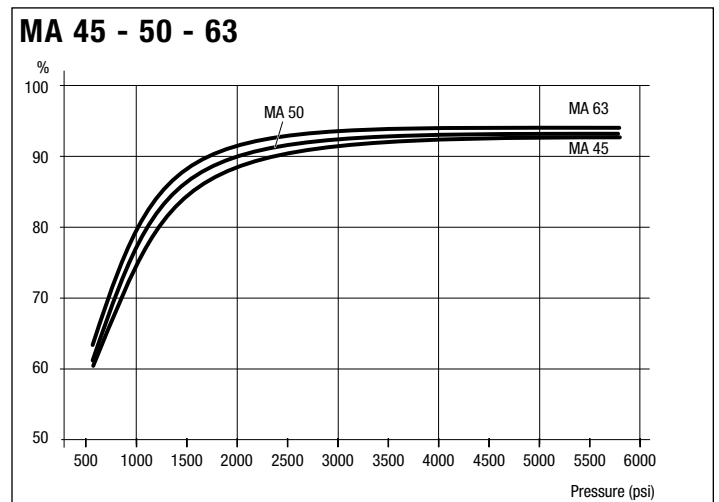
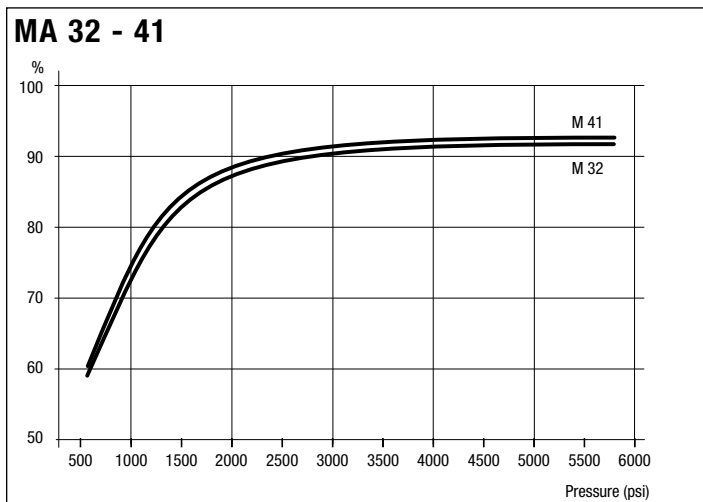
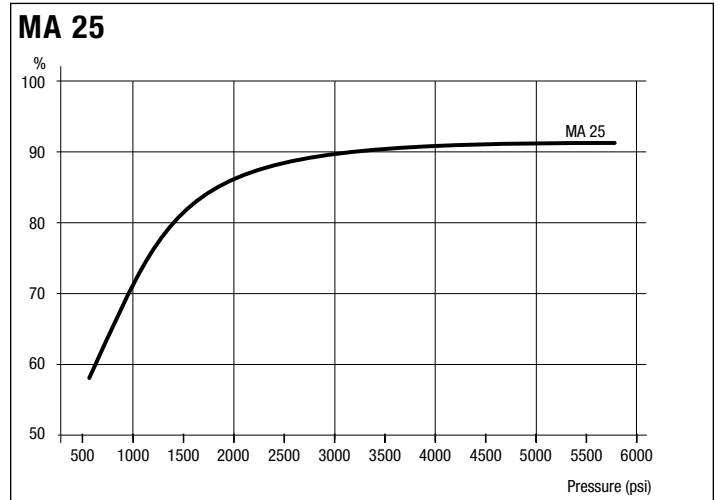
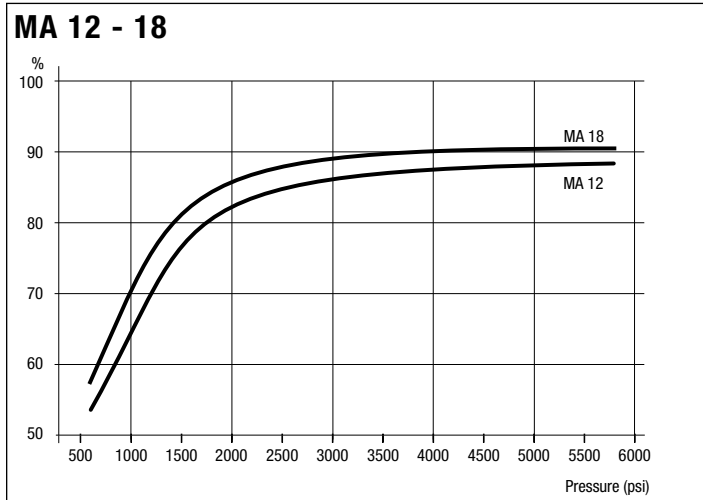

Order code system MA series motors

Order code system for MA type motor

MA	..	C	U2
01	02	03	04	05	06	07	08	09	10

To obtain the code for your motor, complete the different parameters 02, 04, 05, 07, 08, 09 and 10 in the table on the left, according to the options you require (see table below).

01	Motor	Motor										MA				
02	Displacement	12	18	25	32	41	45	50	63	80	90	108R	125			
03	Mounting flange	SAE B 2 Bolts					SAE C 4 Bolts					SAE D 4 Bolts		C		
04	Shaft end	Splined SAE J489														
		Keyed SAE J744														
05	Inlet ports A and B	SAE flange ports	bottom	0	-	-	-	•	•	•	•	•	•	•	L0	
			rear	0	-	-	•	•	•	•	•	•	•	•	M0	
		Threaded	side	1	-	-	•	•	•	•	•	•	•	•	•	N0
			rear	0	•	•	•	•	•	•	•	•	•	•	•	P0
06	Drain ports T1 and T2	-	side	1	•	•	•	•	•	•	•	•	•	•	Q1	
			rear	0	•	•	•	•	•	•	•	•	•	•	Q0	
			side	1	-	-	•	•	•	•	•	•	•	•	Q1	
			rear	0	•	•	•	•	•	•	•	•	•	•	Q0	
07	Suitable for use of speed sensor	yes	1	-	-	-	-	-	-	-	-	-	-	1		
		no	0	-	-	-	-	-	-	-	-	-	-	0		
08	Speed sensor	yes	1	-	-	-	-	-	-	-	-	-	-	1		
		no	0	-	-	-	-	-	-	-	-	-	-	0		
09	Valves	without	SV	-	-	-	-	-	-	-	-	-	-	SV		
		with flushing valve	VB	-	-	-	-	-	-	-	-	-	-	-	VB	
10	Low temperature option	yes (NBR)	N	-	-	-	-	-	-	-	-	-	-	N		
		no (FKM)	F	-	-	-	-	-	-	-	-	-	-	-	F	

Suitability for valves:
 - no 0
 - compatible with flushing valve 1

Dimensions

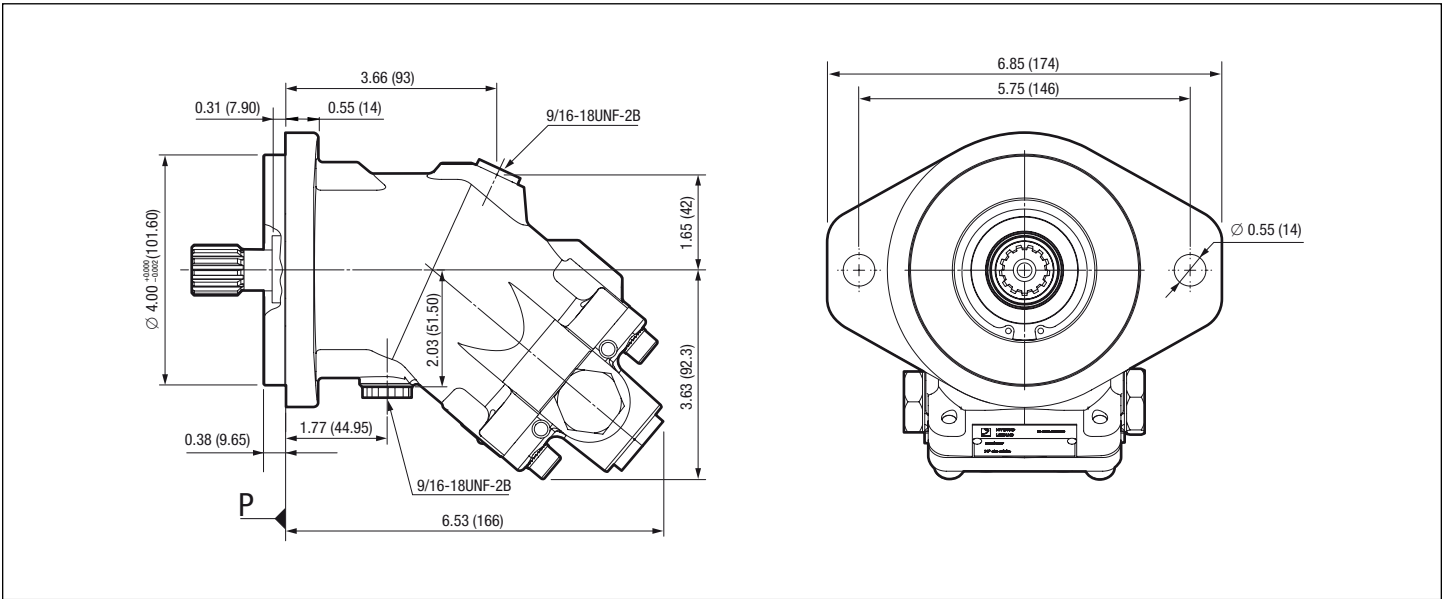

Shaft end

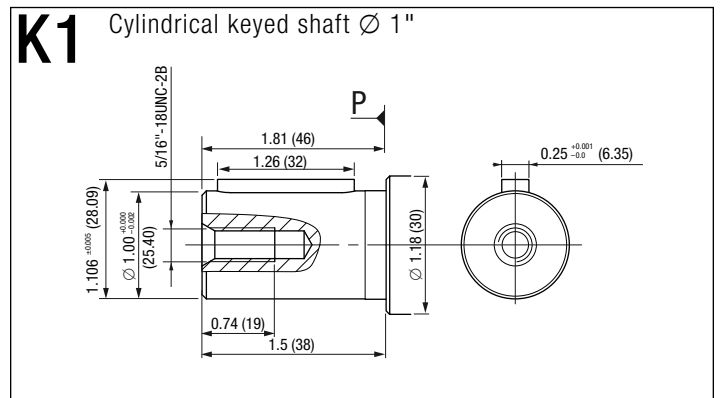
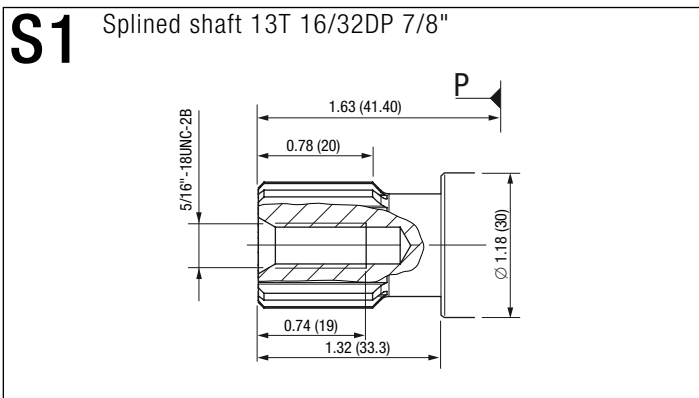

Inlet ports

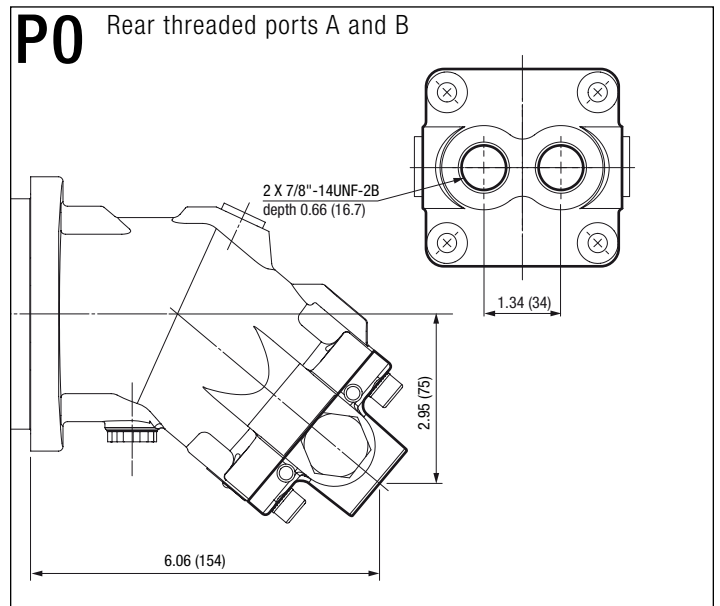
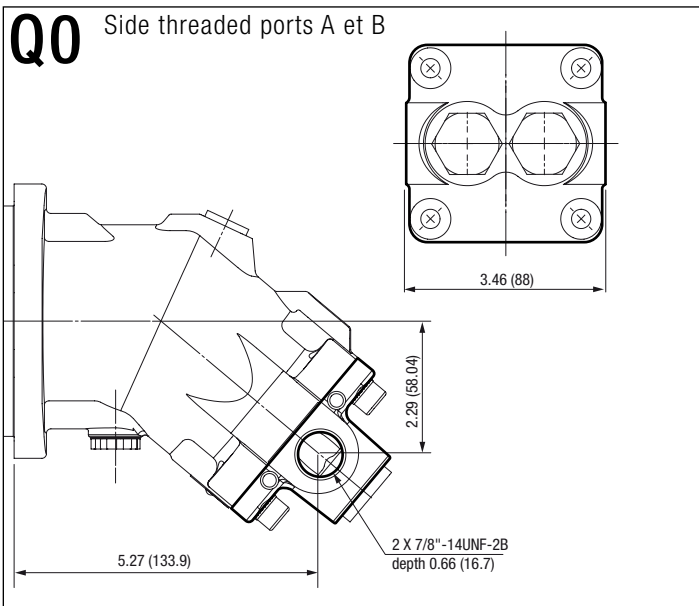

Dimensions

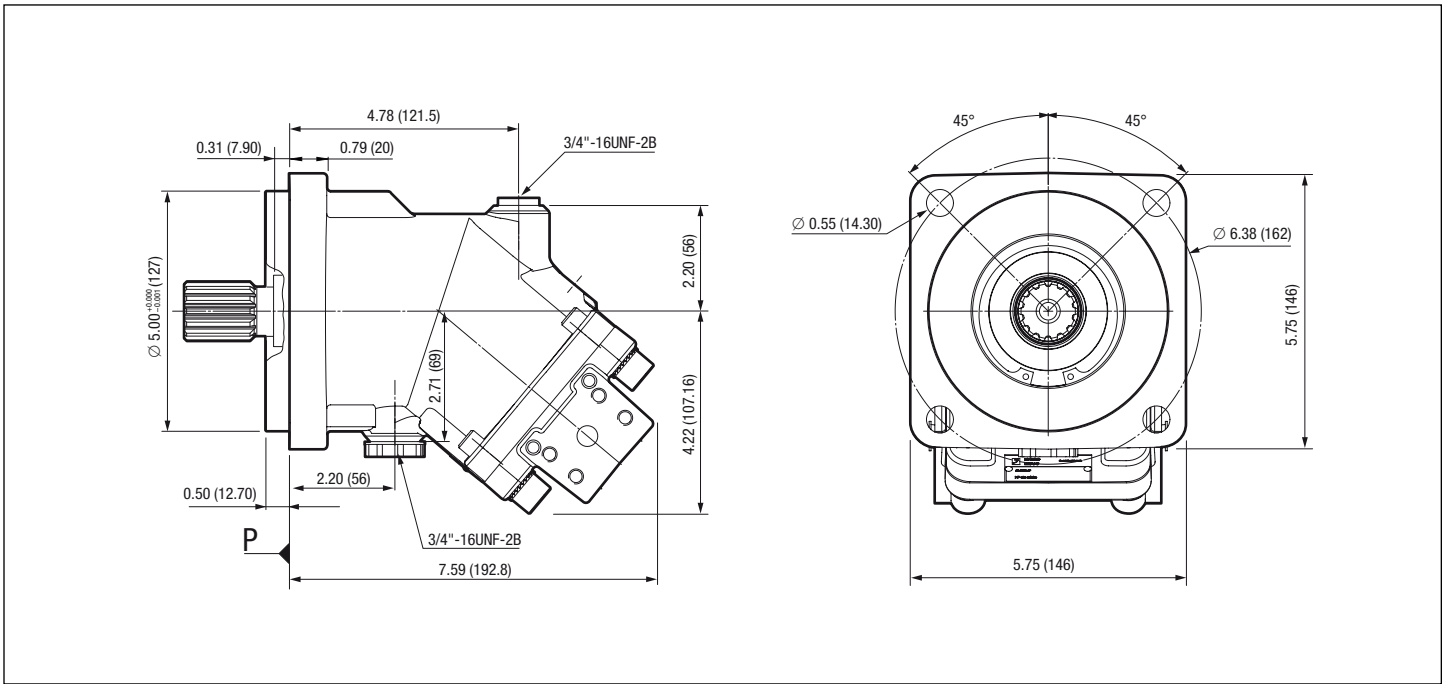

Shaft end

S1 Splined shaft 14T 12/24DP 1 1/4"

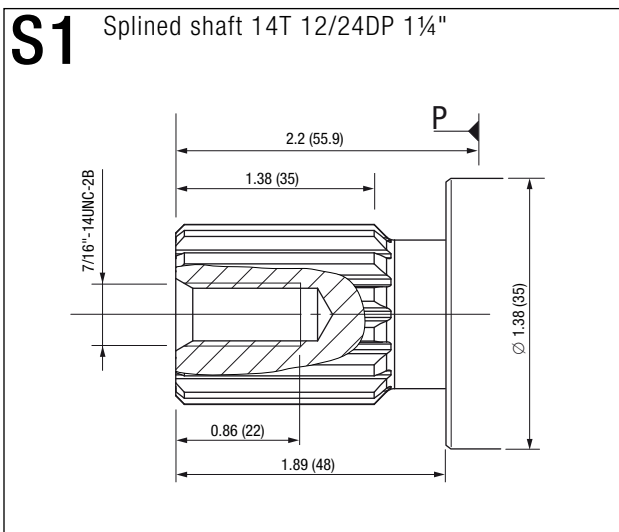

K1 Cylindrical keyed shaft $\varnothing 1 1/4$ "

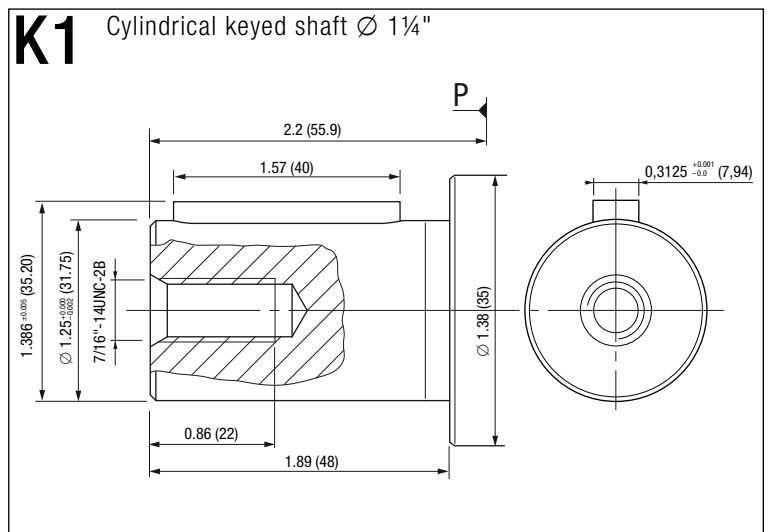

Inlet ports

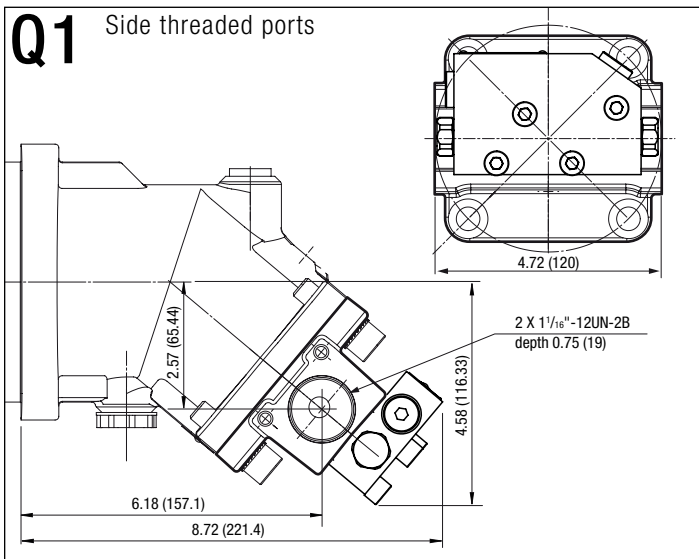
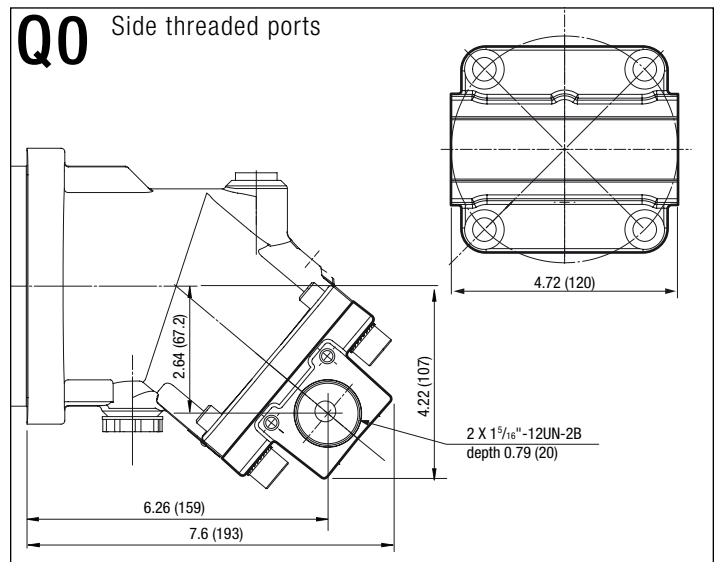
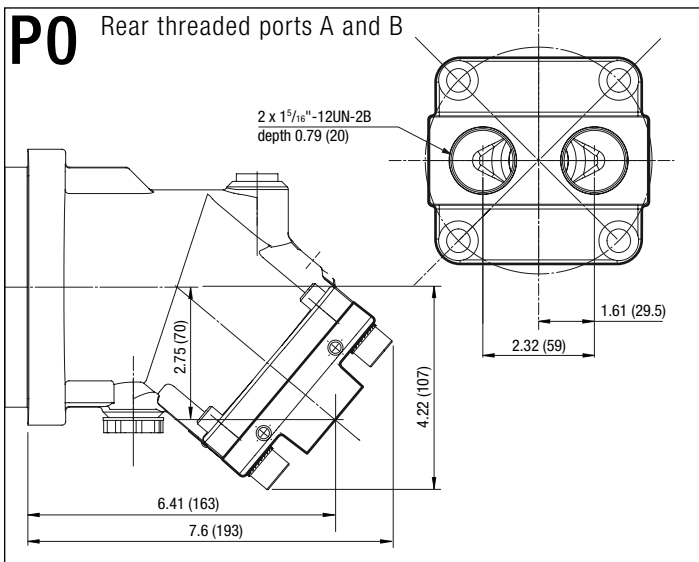
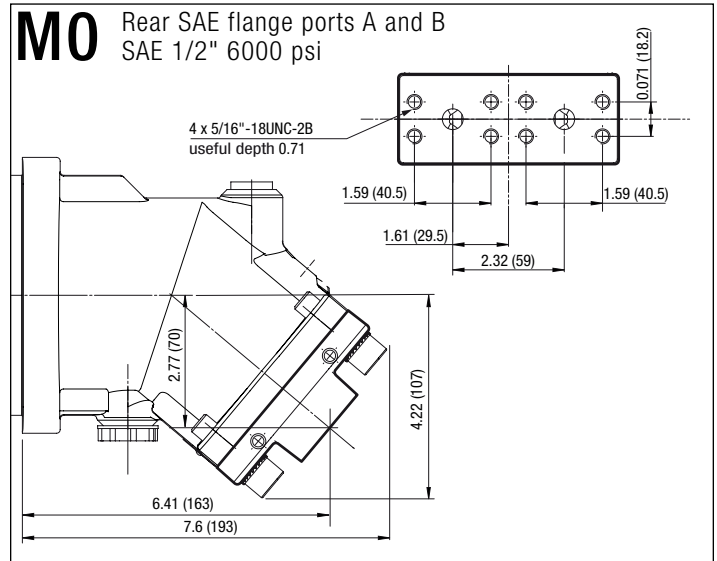
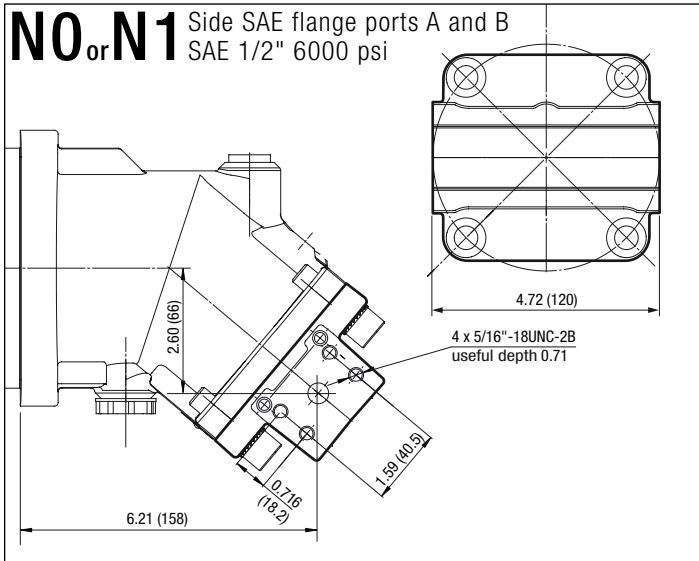

Inlet ports

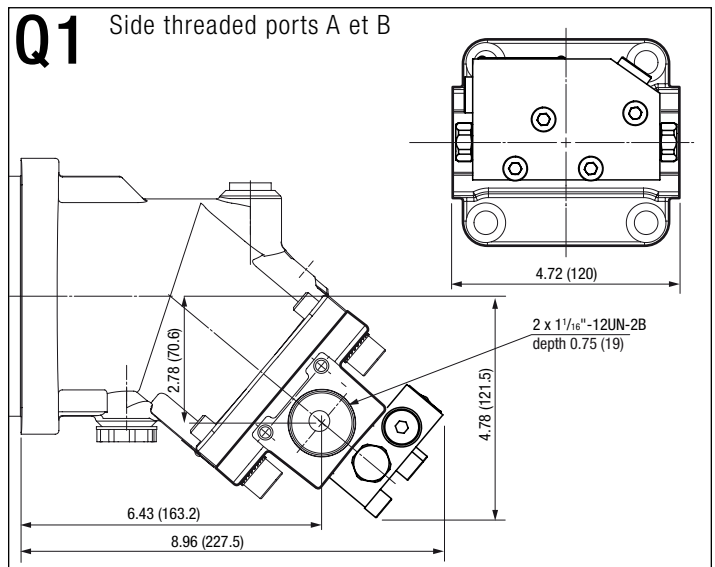
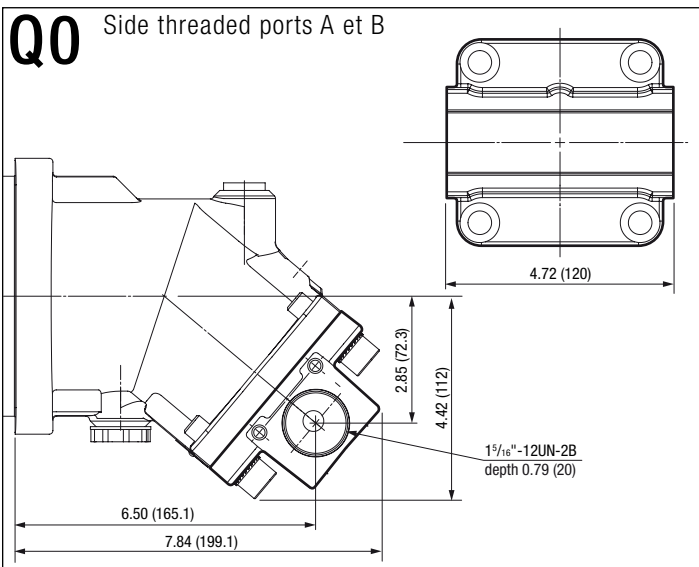
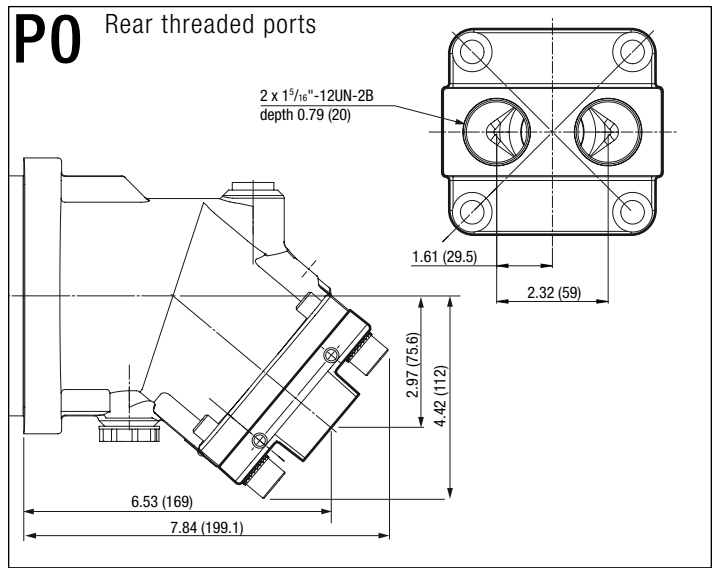
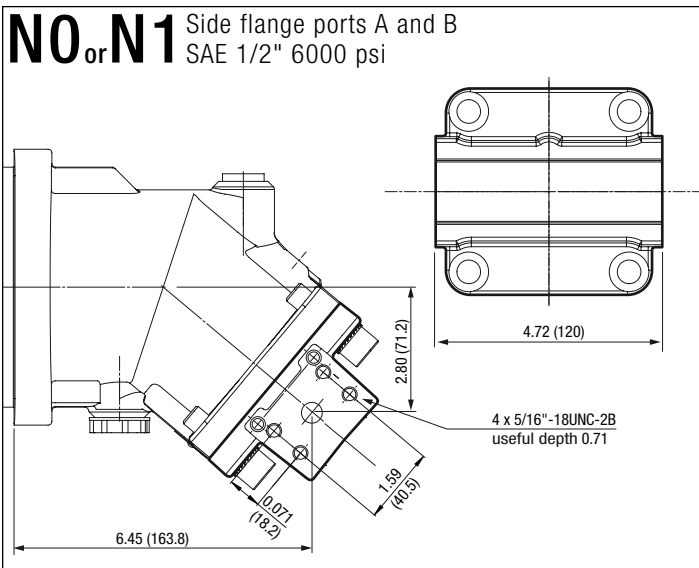
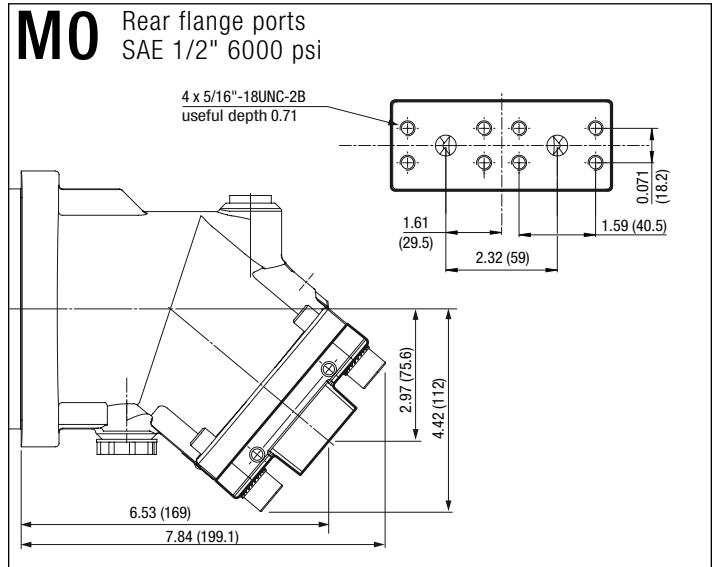
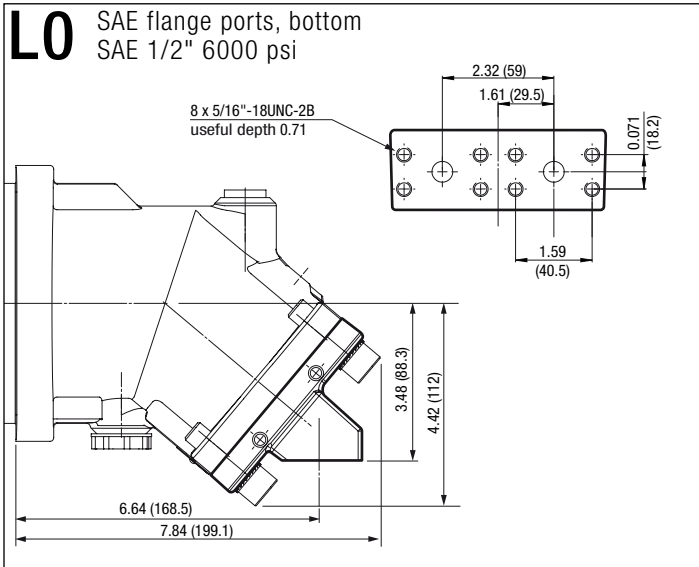

Inlet ports

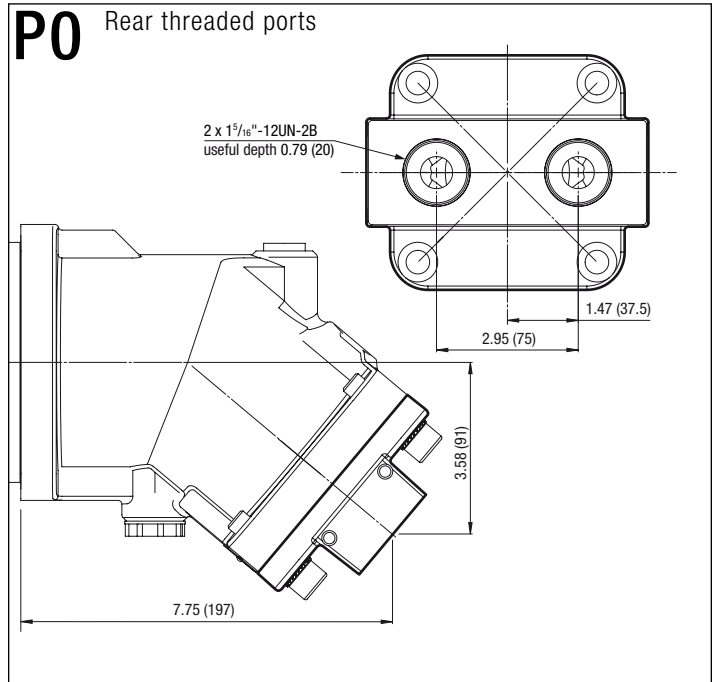
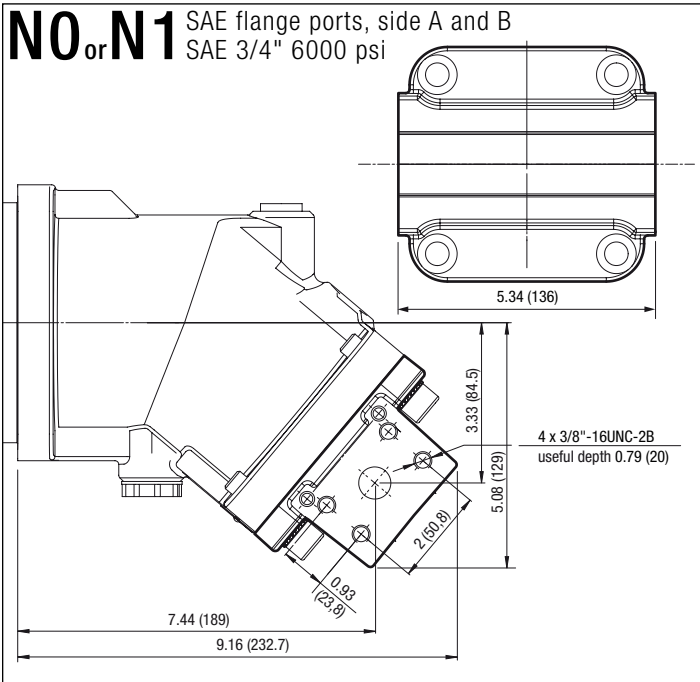
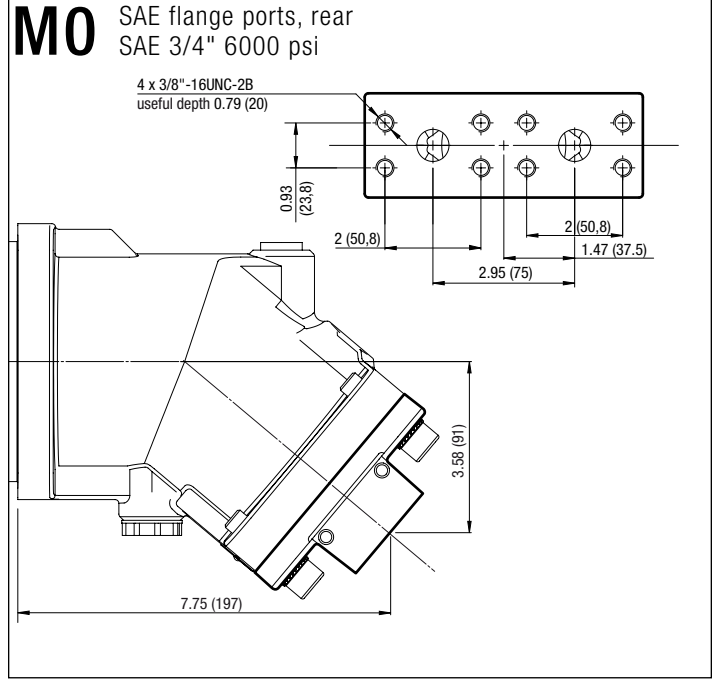
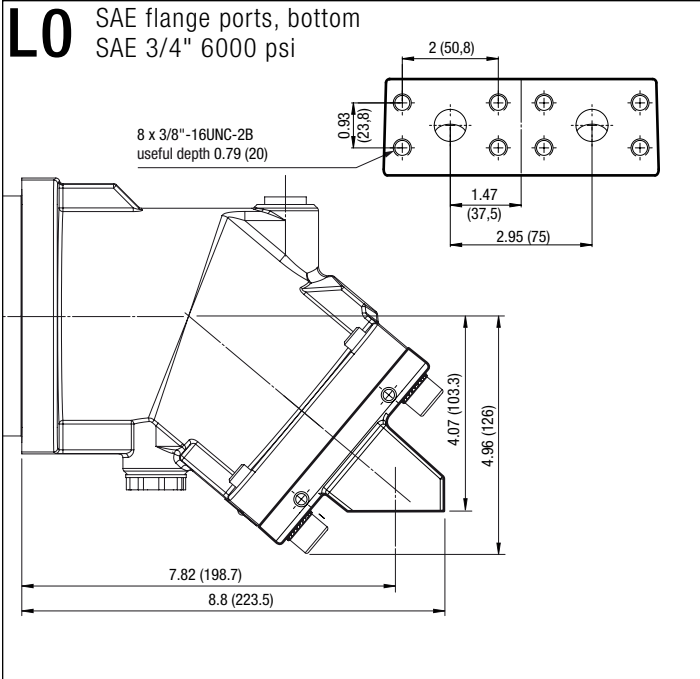

Dimensions

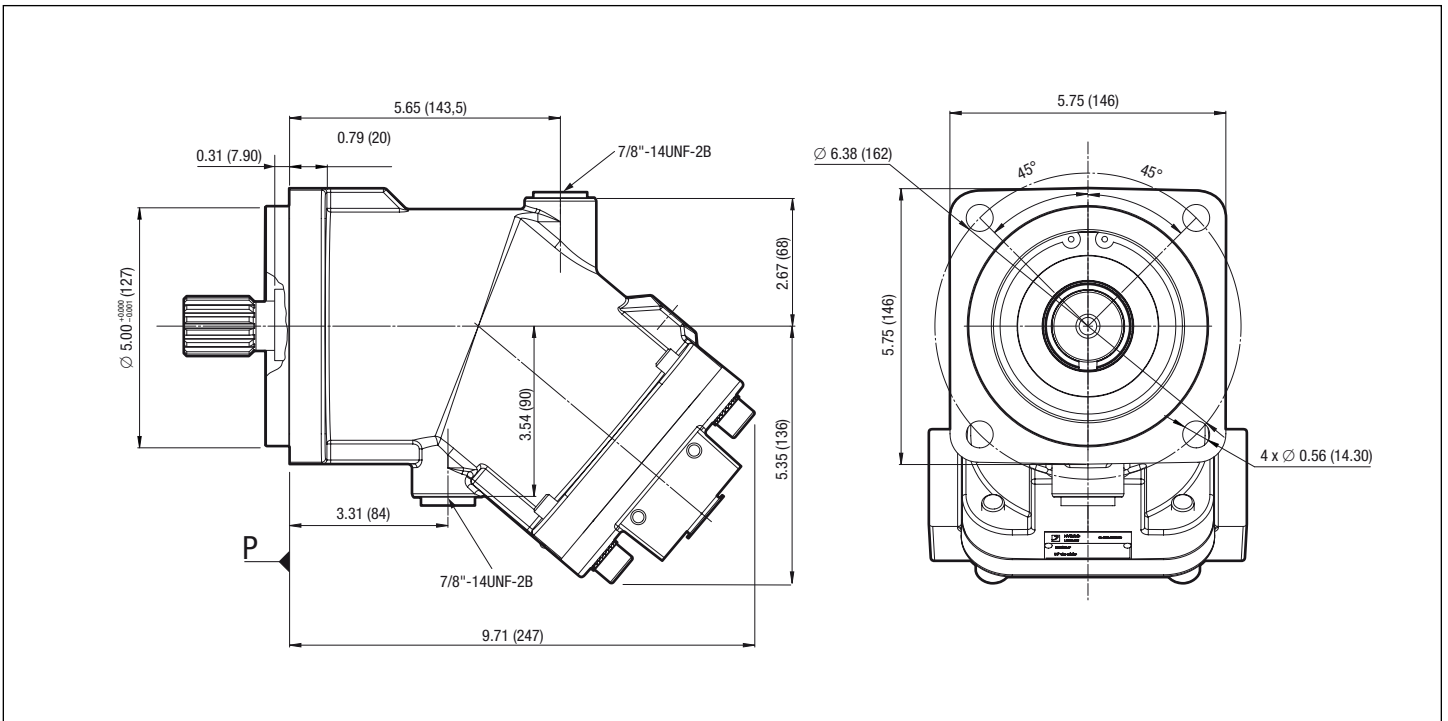

Shaft end

14

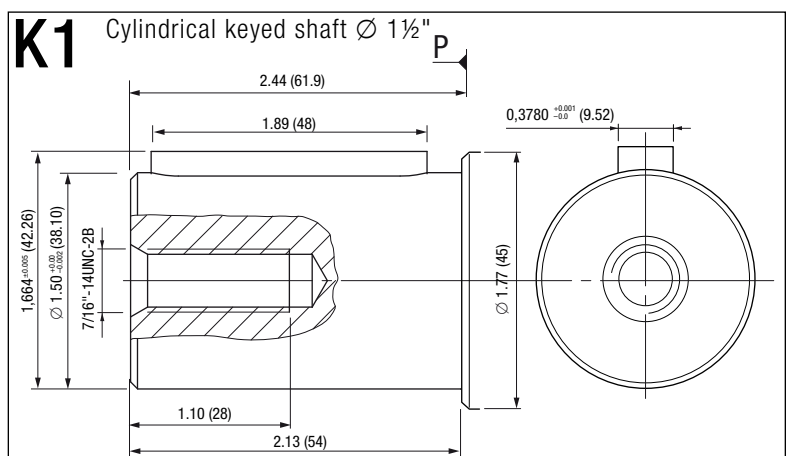
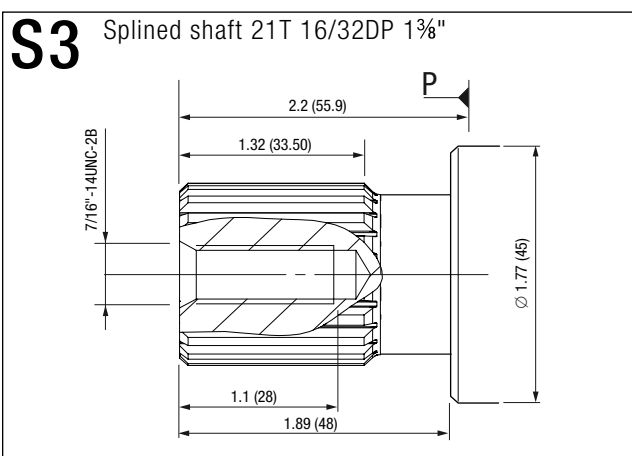
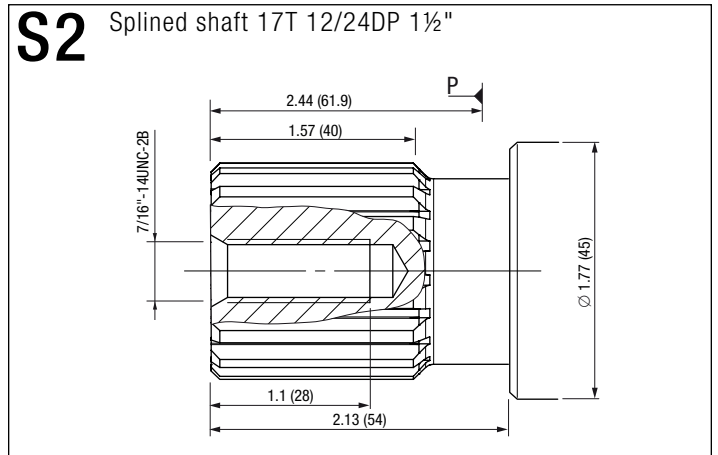
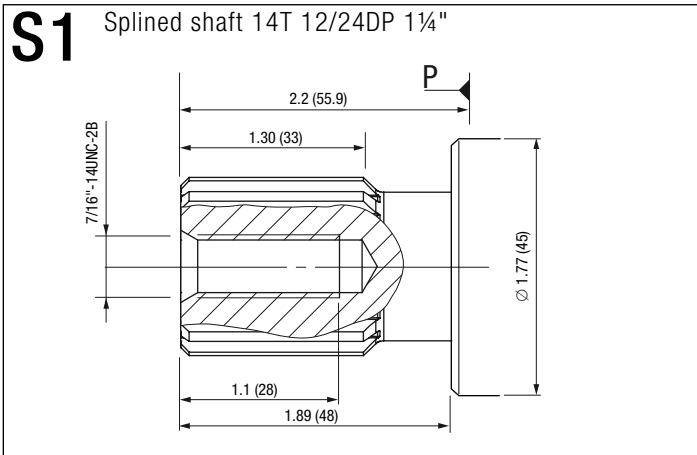

Inlet ports

L0 SAE flange ports, bottom
SAE 1" 6000 psi

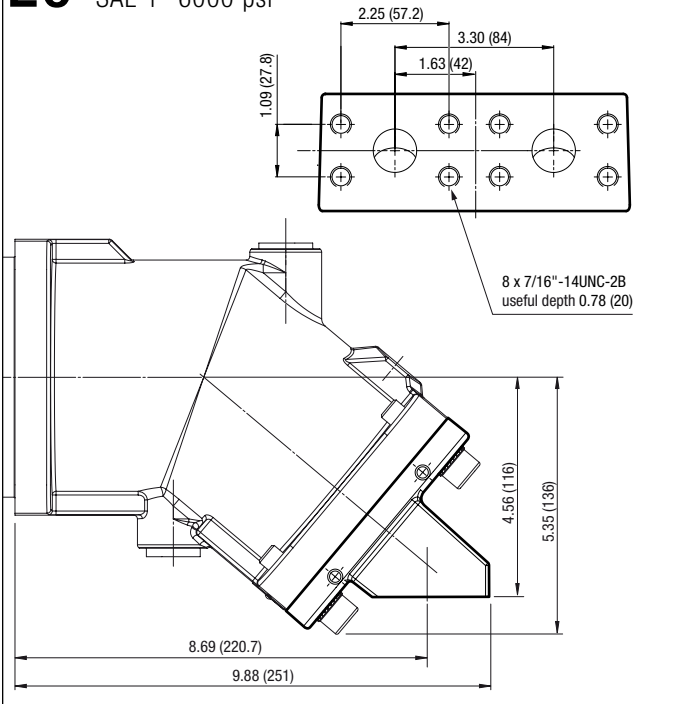

M0 SAE flange ports, rear
SAE 1" 6000 psi

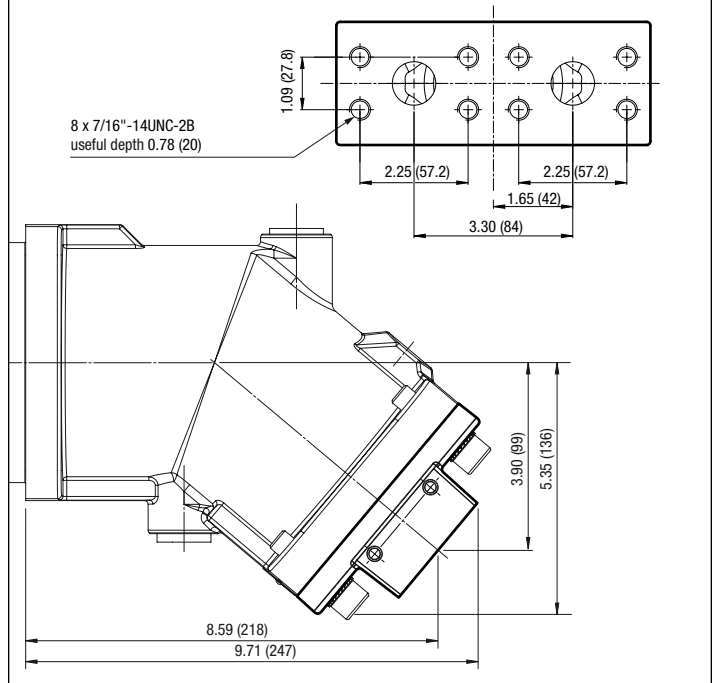

N0 or N1 SAE flange ports, side A and B
SAE 1" 6000 psi

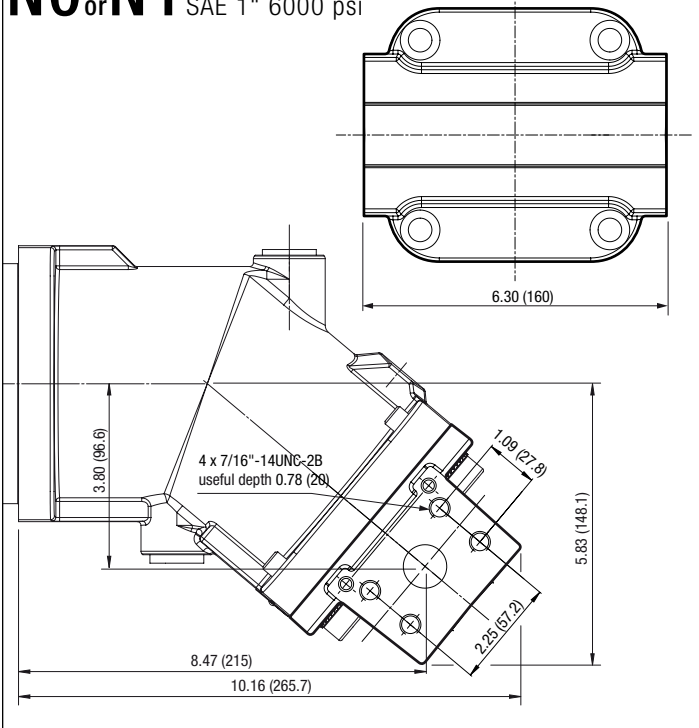

Dimensions

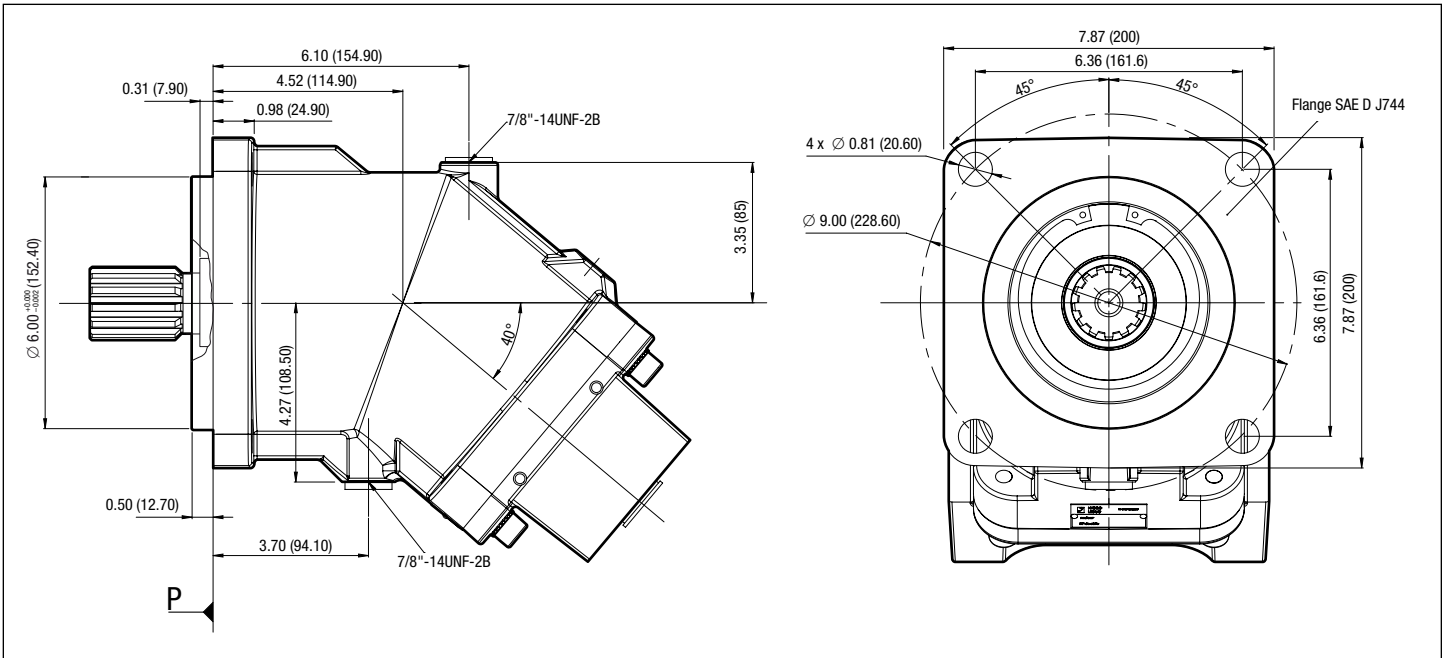

Shaft end

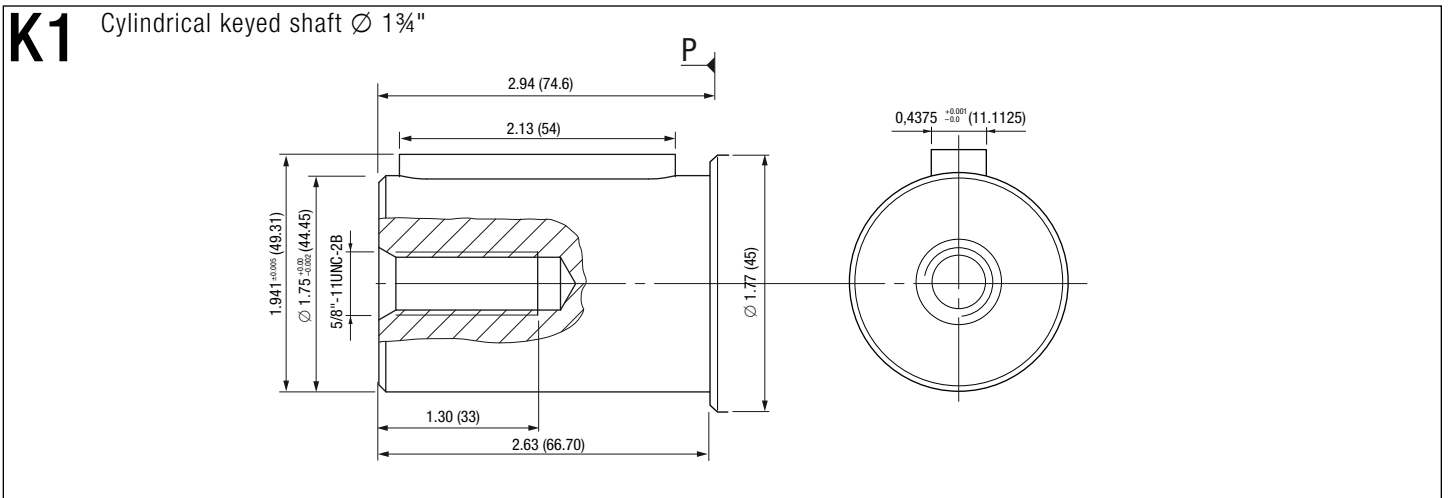
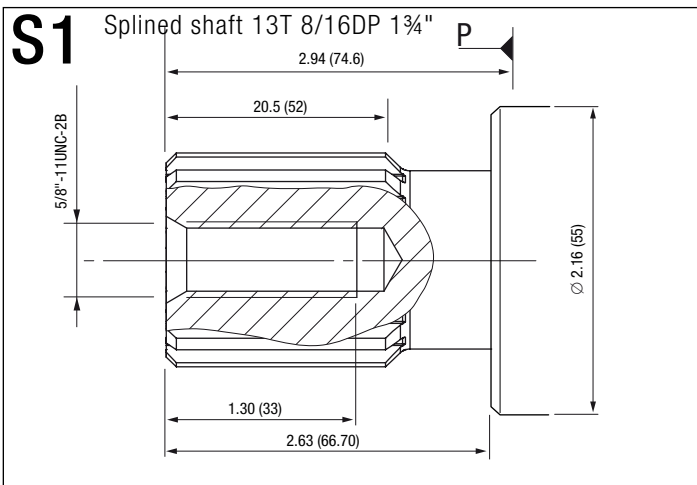

Inlet ports

M0 SAE flange ports, rear
SAE 1 1/4" 6000 psi

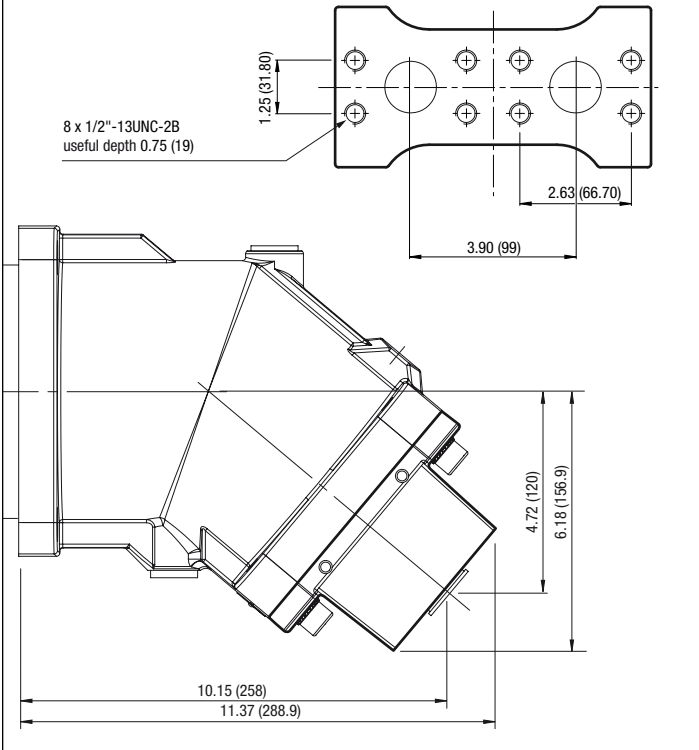

N0 or N1 SAE flange ports, side A and B
SAE 1 1/4" 6000 PSI
MA 108 R

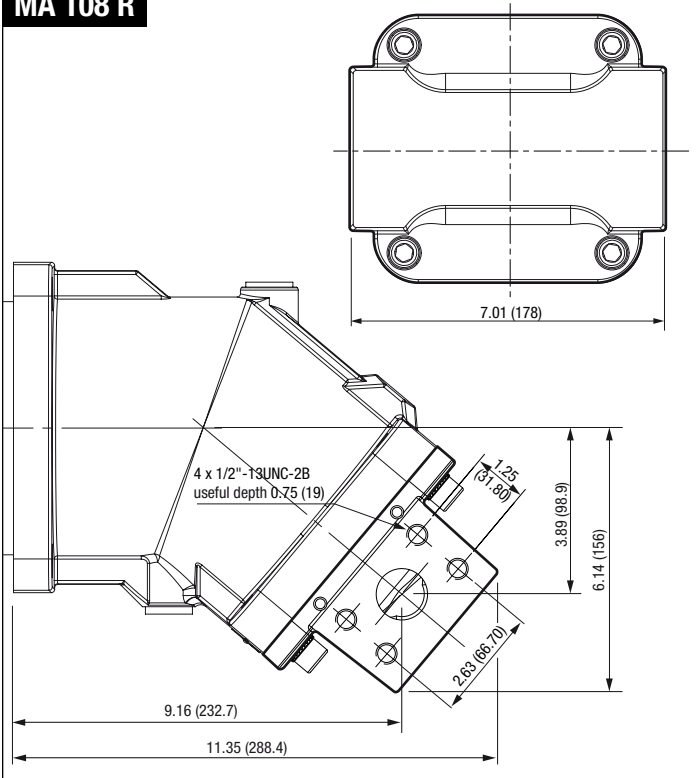

N0 or N1 SAE flange ports, side A and B
SAE 1 1/4" 6000 PSI
MA 125

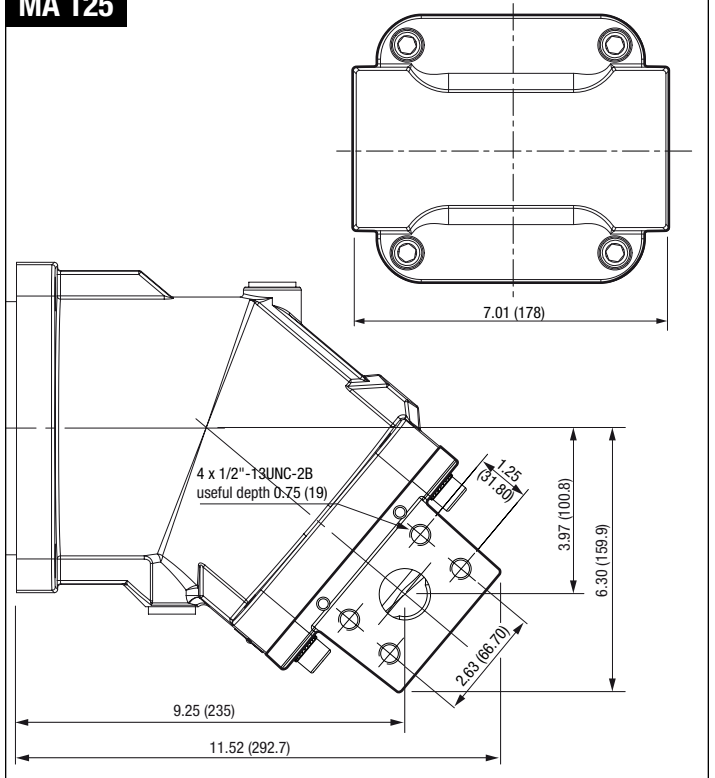

Flushing and resupply valve

Used to create flow to cool the motor. This valve is essential for all intensive uses of motors and contributes to long service life, particularly in closed loop transmission applications.

The valve takes some hydraulic fluid internally from the return connection port (low pressure) and reinjects it into the motor housing. This is then evacuated via the motor drain line.

The flushing and resupply valve is only available for use on motors with side ports (N1 or Q1 in order code).

HYDRO LEDUC reference: VBS 091180.

Schematic:

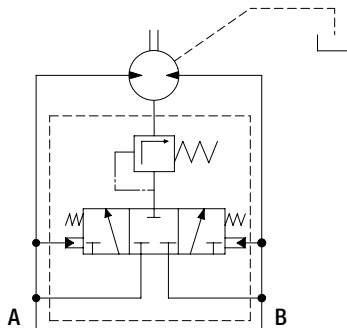

Dimensions:

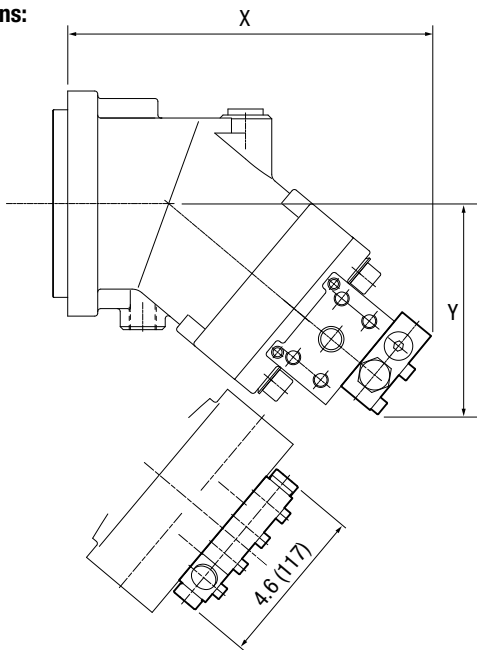

Motor displacement (Cu.In)	X inches (mm)	Y inches (mm)
1.52	8.72 (221.4)	4.58 (116.3)
1.95	8.96 (227.5)	4.78 (121.5)
2.78 - 3.07 - 3.84	10.07 (255.8)	5.41 (137.4)
4.90 - 5.49	11.26 (286)	6.02 (153)
6.61	12.01 (305)	6.17 (156.6)
7.65	12.10 (307.3)	6.24 (158.5)

Speed sensor

The MA series motors can be fitted with an induction type speed sensor, to measure rotating speed and also direction of rotation.

This accessory may only be used on motors which are suitably adapted to take it (see order code system on page 6, parameter no. 7).

HYDRO LEDUC reference: 093327.

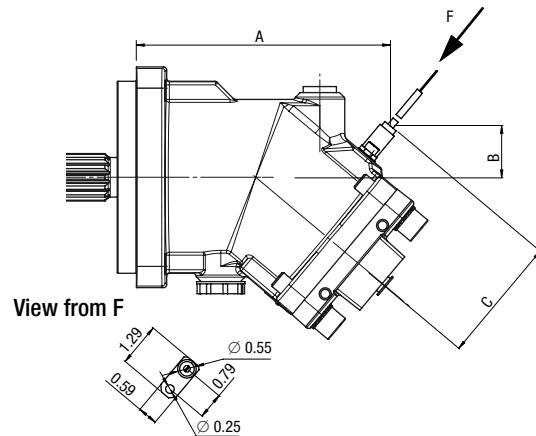

Motor displacement (Cu.In)	A inches (mm)	B inches (mm)	C inches (mm)	Sensor number of tooth
0.73 - 1.1	6.38 (162)	1.26 (32)	3.43 (87)	30
1.52	6.81 (173)	1.61 (41)	3.62 (92)	35
1.95 - 2.50	6.81 (173)	1.61 (41)	3.62 (92)	35
2.78 - 3.07 - 3.84	7.6 (193)	1.38 (35)	3.78 (96)	39
4.90 - 5.49	8.78 (223)	1.18 (30)	3.98 (101)	44
6.61 - 7.65	9.88 (251)	1.77 (45)	4.8 (122)	64

Note: maximum tightening torque = 7 lbf ft (10 m.N)
For further information, please contact us.

Technical data for the sensor:

Supply voltage**	5...32 V DC
Current consumption	maximum 6 mA without load
Output frequency	0 Hz...6kHz
Protection type	IP 69 k
Operating temperature	- 40°C...+ 125°C
Weight	around 65 g

■ LEDUC motors are certified ATEX.

As standard, all LEDUC motors are classed in Group **II** category **2 D T4**.

On request, motors may be supplied for:

- Group **II** category **2G**;
- Group **II** category **D T4**.

In these cases, the motors are not painted and are open to risk of corrosion.

Explanation of the different groups:

- **group II category 2** means it is possible to operate in an **ATEX 1** zone (probable gas atmosphere) or **ATEX 21** zone (probable dusty atmosphere).
- **G** = may operate in a gas zone.
- **D** = may operate in a dusty atmosphere.
- **T4** : maximum surface temperature of 135°C.

■ Precautions regarding ATEX

The operating temperatures of the motors must be guaranteed by the end user.
Check all parts connected to the motor for conformity with ATEX.

■ Markings on motors

Example of ATEX marking on motors:

 **II 2 D c T4 (135°C) HL 1**

If you have different requirements, please contact us.

1

2

3

4

- 1 Dimensional control of motor housing
- 2 Assembly of motor
- 3 Spline cutting (shaft)
- 4 MA motors



Installation and start-up MA series motors

Maximizing service life of bearings

In cases where there is a radial force on motor shaft, keeping the direction of that force within the shaded areas shown below will improve service life of the motor. For acceptable radial and axial forces, see page 4.

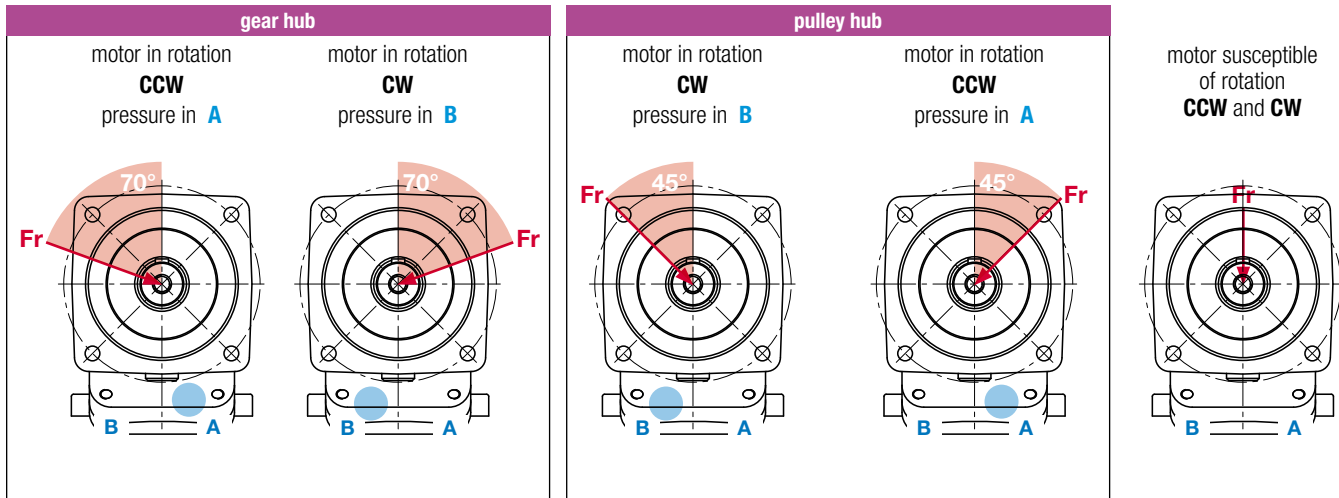

Mounting position of motors

LEDUC motors can be used in any position.

In position «shaft upwards», make sure that the motor housing is completely filled with fluid.

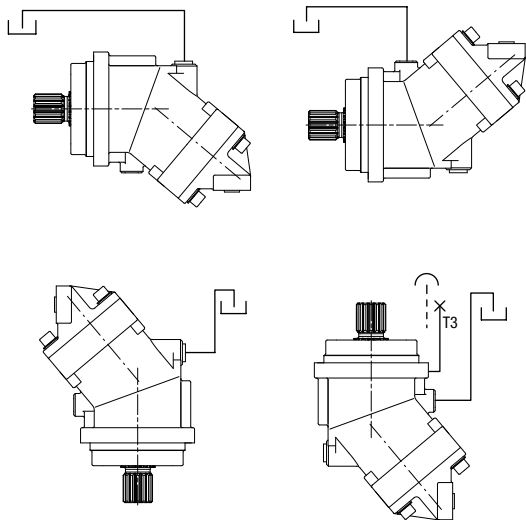

In installations where the position of the motor (H) is above the tank for the drain return, be sure the drain line is always submerged in fluid. If this is not the case, it is necessary to add a check valve on the drain line following the figure below.

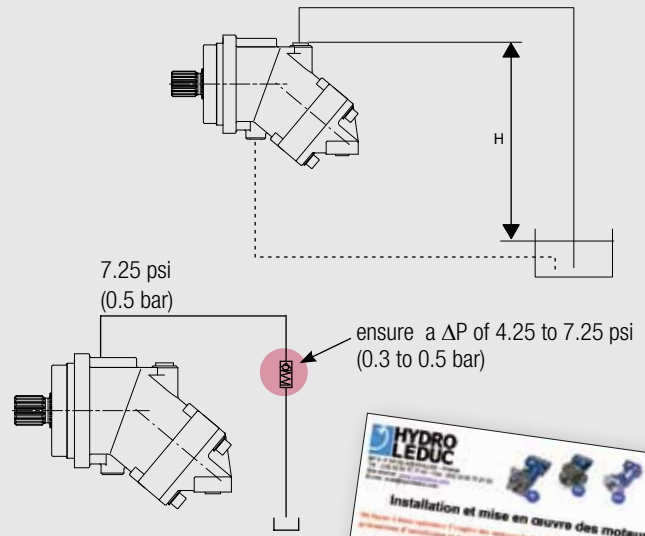

Operating conditions

See page 2.

Instructions for use

Each motor is supplied with an instruction leaflet, also available via e-mail on request mail@hydroleduc.com.

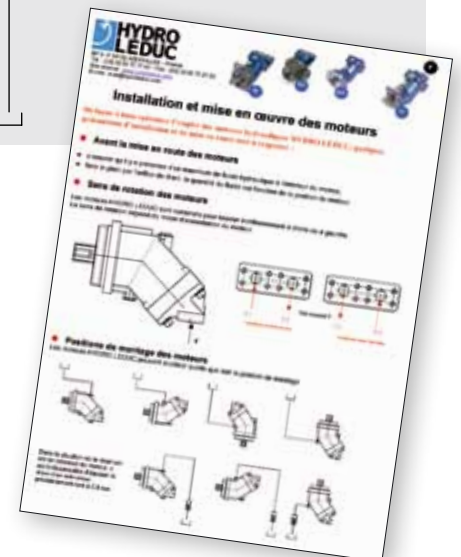

other product lines

piston pumps for trucks

HYDRO LEDUC offers 3 ranges of piston pumps perfectly suited to all truck, construction equipment, and PTO-mount applications. Fixed and variable displacement from 12 to 150 cm³ (0.73 to 9.25 Cu.In).



mobile and industrial pumps

Fixed displacement pumps, the W series, and variable displacement pumps, the DELTA series. High pressure capabilities within minimal size.

W series: flanges to ISO 3019/2, shafts to DIN 5480.
DELTA series: SAE shafts and flanges.

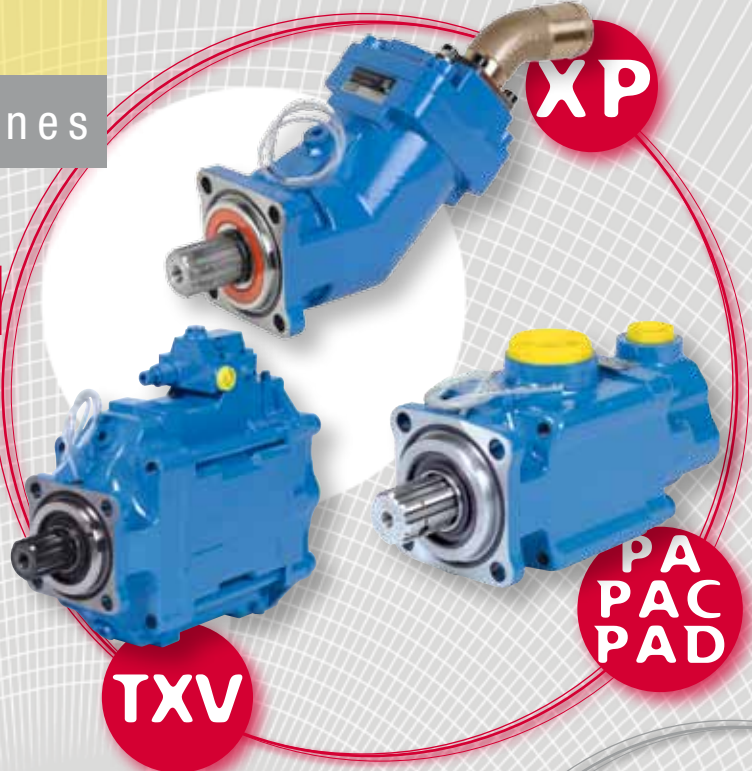

micro-hydraulics

This is a field of exceptional HYDRO LEDUC know-how:

- axial and radial piston pumps, of fixed and variable displacement,
- axial piston micro-hydraulic motors,
- micro-hydraulic units incorporating pump, electric motors, valving, controls, etc.

To users of hydraulic components which have to be housed in extremely small spaces, HYDRO LEDUC offers complete, original and reliable solutions for even the most difficult environments.



hydro-pneumactical accumulators

Bladder, diaphragm and piston accumulators.
Spherical and cylindrical accumulators.
Volume capacities from 1.22 Cu.In to 13.21 gallons (20 cc to 50 liters).
Pressures up to 7250 psi (500 bar).
Accessories for use with hydraulic accumulators.

**we are passionate
about hydraulics...**



A dedicated R&D team means HYDRO LEDUC is able to adapt or create products to meet specific customer requirements. Working in close cooperation with the decision-making teams of its customers, HYDRO LEDUC optimizes proposals based on the specifications submitted.

A passion for hydraulics

HYDRO LEDUC

Head Office & Factory
BP 9 - F-54122 AZERAILLES (FRANCE)
Tél. +33 (0)3 83 76 77 40
Fax +33 (0)3 83 75 21 58

HYDRO LEDUC GmbH

Haselwander Str. 5
D-77746 SCHUTTERWALD (DEUTSCHLAND)
Tel. +49 (0) 781-9482590
Fax +49 (0) 781-9482592

HYDRO LEDUC N.A., Inc.

14515 Briar Hills Parkway - Suite 116
HOUSTON, TEXAS 77077 (USA)
Tel. +1 281 679 9654
Fax +1 281 596 0903



Complete catalogues available at:
www.hydroleduc.com

HYDRO LEDUC

SAS with capital of 4 065 000 euros

Siret 319 027 421 00019

RC Nancy B 319 027 421

mail@hydroleduc.com

