



Brochure

Baldor explosion proof AC and DC Motors

We provide motors, generators and mechanical power transmission products, services and expertise to save energy and improve customers' processes over the total lifecycle of our products, and beyond.



Baldor Explosion Proof AC and DC Motors

Part number/Index

Specifications and Features

- 4 Energy Savings
- 5 Division 1 Capabilities
- 6 North American Certifications
- 8 Outside North America Certifications
- 10 Design Features

Motor Performance Data and Dimensions

- 12 Rigid Base
- 16 C-Face
- 20 Severe Duty
- 21 Drill Rig Duty
- 23 50 Hz
- 24 Brake Motors
- 24 Pump Motors
- 26 Submersible
- 27 Adjustable Speed AC Motors
- 30 Adjustable Speed DC Motors

- 31 Motor Dimensions
- 42 Connection Diagrams

Baldor Explosion Proof AC and DC Motors

Why Baldor?

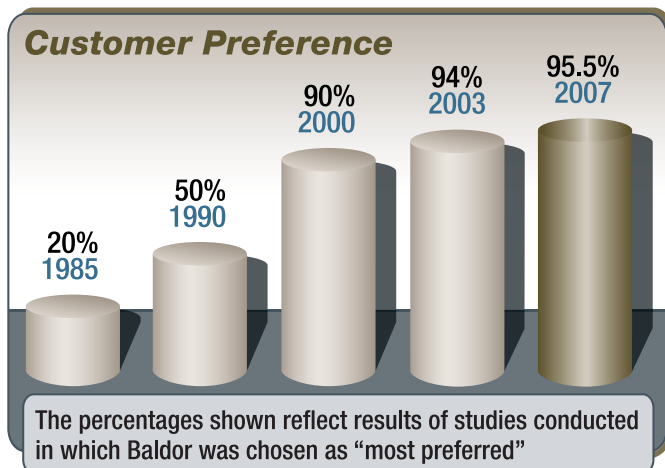

For nearly 100 years, Baldor has strived to provide customers with the best value and reliability in industrial electric motors. That dedication shows in customer preference for Baldor•Reliance motors. To be considered as the most preferred...

Baldor offers the industry's broadest line of stock products.

Save valuable time with just one call to Baldor. We offer more than 10,000 stock motors, drives and gearboxes.

Energy-efficiency leader. We began lowering the energy consumption of our motors in the 1920s, long before others were even talking about it. Today, our expansive line of Super-E® premium-efficient motors ranges from 1 through 15,000 Hp. Baldor's Super-E® line offers customers the highest overall efficiency levels in the industry.



Baldor products are available at more locations than any other brand.

Our 35 district offices across North America and hundreds of ABB offices around the world, offer immediate availability of Baldor products to thousands of customers.

Continuous innovation to improve reliability.

Baldor leads the motor industry in applying new technologies to improve motor reliability. Recent improvements to the line of Severe Duty motors are further proof that Baldor is the leader in motors for process industry applications. These improvements are explained in detail in the following pages.



Industry's shortest lead times/Flexible manufacturing.

Baldor has the industry's shortest lead times on custom motors – just ten working days. Our unique LEAN FLEX FLOW™ manufacturing process lets us produce any order in any quantity, quickly and efficiently.

Industry's best information. Only Baldor offers customers so many choices for product information with a wide variety of catalogs and product brochures, the Baldor Web site at www.baldor.com, or you may talk to a Baldor customer service person at one of our sales offices.

Baldor Explosion Proof AC and DC Motors

Explosion Proof Motors

Since the 1940s, when Baldor introduced its first explosion-proof motor, the company has designed and manufactured motors that meet or exceed industry standards, ensuring safety, energy efficiency and overall reliability.

When you specify a Baldor explosion-proof motor, you can trust that it meets your specifications, and more. Baldor follows the specs to the letter, and then takes it a step further. We listen to motor users and learn from their experiences. We design and build motors that deliver reliable performance. And we earn long-term customer relationships by exceeding their expectations.

Over 500 Stock Motor Ratings

Today, Baldor offers customers a wide range of AC and DC Explosion Proof motors directly from stock, including your choice of premium efficient or standard efficient motors, in ratings from 1/4 to 300 horsepower. Non-stock motors are delivered in as few as ten working days.

The Right Motor for your Hazardous Environment Application

Baldor has a wide range of motors that are certified for use in Hazardous Locations or potentially Hazardous Environments where concentrations of combustible gasses, vapors and or dust are present or present some of the time.

Typical customer applications that are in Class I Environments (flammable gases & vapors) include:

- Spray painting and finishing areas
- Utility gas plants
- Petroleum refining plants
- Petroleum dispensing locations
- Dry cleaning facilities
- Dip tanks containing combustible or flammable fluids
- Plant facilities extracting solvents
- Inhalation anesthetic areas
- Process facilities manufacturing or using nitro-cellulose (class II as well).
- Aircraft hangars and fuel servicing areas.
- Gas stations

Typical customer applications that are in Class II Environments (combustible dust) include:

- Flour mills
- Feed mills
- Grain elevators and grain handling facilities
- Fire work plants and storage areas
- Aluminum manufacturing and storage areas

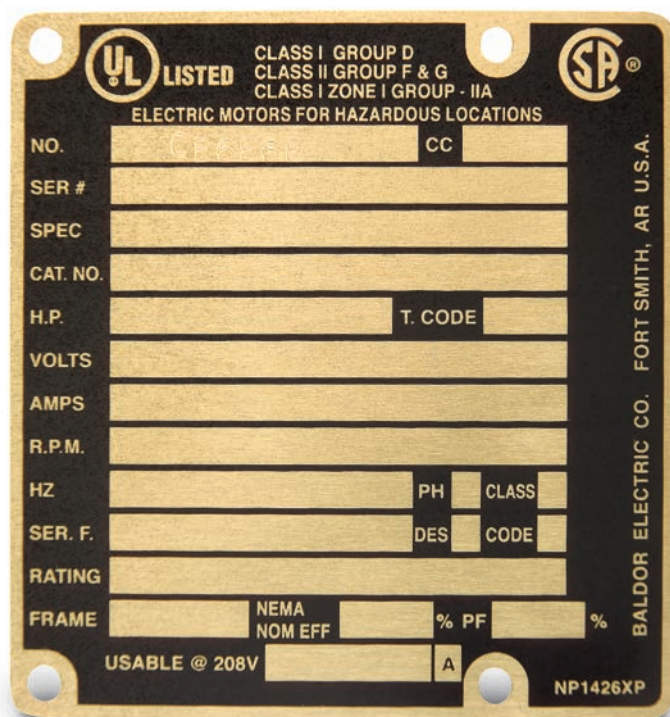

Baldor Explosion proof motors are easily recognizable by their nameplates that include the listing agency approval logos as well as all specific Class, Group and Temperature Code information.

- Magnesium manufacturing and storage areas.
- Coal preparation and handling facilities
- Starch manufacturing and storage areas
- Confectionary plants
- Pulverized sugar and cocoa manufacturing plants. Packaging and storage plants.
- Spice grinding and storage plants.

Leadership in Premium Efficiency

As countries and regions across the world establish minimum efficiency levels for motors, more companies are turning to the Baldor•Reliance Super-E. This includes plant and processing applications, as well as OEM products for shipment overseas. Super-E motors meet or exceed the efficiency levels defined by The Energy Independence & Security Act of 2007 (EISA) in the U.S., NRC in Canada, and IEC 60034-30 IE3 level in Europe. Super-E motors meet or exceed NEMA Premium® efficiencies.

A wide selection of premium efficient motors, available from stock, manufactured and sold by a company committed to building better products for industries worldwide. No wonder, since the 1920s, Baldor is recognized as the worldwide leader in energy efficient motors and drives.

Baldor Explosion Proof AC and DC Motors Energy Savings

Making Energy Efficiency Work For You

Why is Energy Efficiency Important?

Electric motor-driven systems used in industrial processes consume 63% of all electricity used in U.S. industrial sector according to a U.S. Department of Energy report published in 1998. A 2002 report shows that companies that practiced DOE "best practices" actually averaged 33 percent savings if they were to apply motor and motor system efficiency upgrades, including the use of adjustable speed drives. The potential positive impacts on companies' bottom lines and the environment are significant.

Purchase Price is Only a Small Piece of the Pie

The pie chart to the right shows the typical life cycle cost of a 100 Hp motor operating in continuous duty over a 20-year life. As you can see, the original purchase price is almost insignificant compared to what it will cost to power the motor during its useful life.

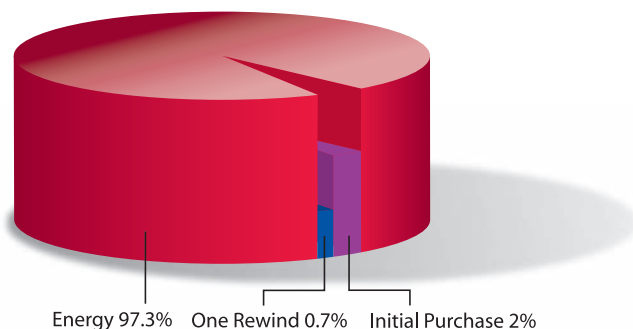

How Baldor Super-E® Efficiencies Compare to Industry Standards

Baldor's line of Super-E motors offers customers the highest level of overall efficiencies available from any motor manufacturer, meeting or exceeding NEMA Premium® efficiency.

BE\$T™ Baldor Energy Savings Tool Makes Calculating Payback Easy

In order to make payback calculations easier for customers, Baldor developed BE\$T, Baldor Energy Savings Tool. The software helps calculate energy cost and energy savings for motors, as well as payback time frames. A popular feature of BE\$T is that it allows users to make head-to-head comparisons of up to three motors, giving customers the information to make an informed decision through comparative analysis.

BE\$T, Baldor Energy Savings Tool is available as a download through Baldor's award-winning Web site ([www.baldor.com/support/software_BE\\$T.asp](http://www.baldor.com/support/software_BE$T.asp)), as well as a stand-alone CD-ROM, available from your Baldor District Office.

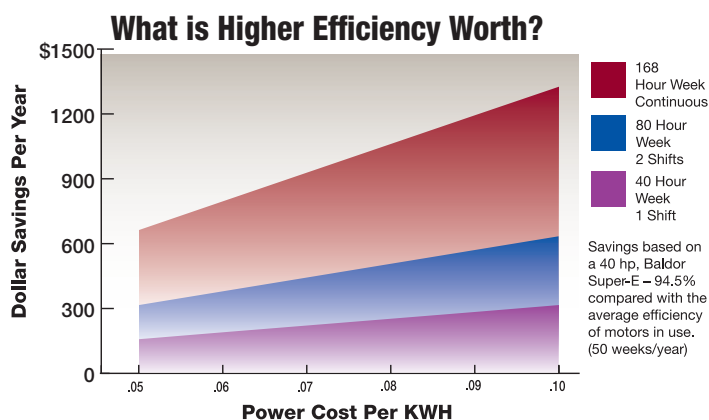
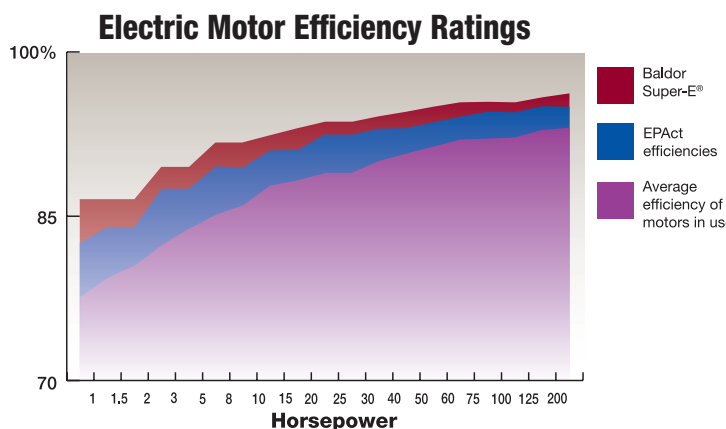

Baldor Explosion Proof AC and DC Motors

Division 1 Capabilities

Baldor Division 1, Explosion Proof Motor Capabilities – 1/4 Hp to 800 Hp NEMA Frame Size Capability

Division 1 enclosures: available as Class 1, Group C&D and Class II, Groups F&G in all sizes. Class I, Group D and Class II, Groups E,F&G are available in Cast Iron frames 182T and larger.

Single Phase – 1/4 to 5HP (48 to 215T frame), Three Phase – 1/4 to 300HP (48 to 449 frame)

Hp	kW	3600 RPM	1800 RPM	1200 RPM	900 RPM
0.25	0.18	–	48	–	–
0.33	0.25	48	48	56	–
0.50	0.37	56	48	56	143T
0.75	0.56	56	56	56	145T
1	0.75	56	56	56	182T
1.5	1.12	143T	56	145T	184T
2	1.5	145T	56	184T	213T
3	2.2	145T	182T	213T	215T
5	4	184T	184T	215T	254T
7.5	5.6	184T	213T	254T	256T
10	7.5	215T	215T	256T	284T
15	11	254T	254T	284T	286T
20	15	256T	256T	286T	324T
25	18.7	284TS	284T	324T	326T
30	22.4	286TS	286T	286T	364T
40	29	324TS	324T	364T	365T
50	37	326TS	326T	365T	404T
60	44	364TS	364T	404T	405T
75	56	365TS	365T	405T	444T
100	75	405TS	405T	444T	445T
125	93	444TS	444T	445T	447T
150	112	445TS	445T	449T	449T
200	149	449TS	447T	449T	–
250	187	449TS	447T	449T	–
300	224	449TS	449T	–	–

Above NEMA Frame Capabilities

All Large AC Division 1 motors have the following specifications: TEFC Enclosure, 1.0 service factor, 40C ambient, B rise at 1.0 SF Cast aluminum rotor, Rigid shaft, Anti-friction bearings, Self-greasing

Division 1 Enclosures: available as Class 1, Group C&D, and may be combined with Class II, Group E, Group E&F, Group F&G, Group G.

Three Phase: 460, 2300, 4000 Volts

Hp	kW	3600 RPM	1800 RPM	1200 RPM	900 RPM
150	112	E449	E449	E449	E5010
200	149	E449	E449	E5010	E5010
250	187	E5010	E5010	E5010	E5810
300	224	E5010	E5010	E5810	E5810
350	261	E5010	E5010	E5810	E5810
400	298	E5010	E5010	E5810	E5810
450	336	E5010	E5810	E5810	E5810
500	373	–	E5810	E5810	E5810*
600	447	–	E5810	E5810	–
700	522	–	E5810	E5810*	–
800	597	–	E5810*	–	–

NOTE: ** denotes Copper Bar Rotor.

Three Phase: 6600 Volts

Hp	kW	3600 RPM	1800 RPM	1200 RPM	900 RPM
250	187	E5010	E5010	E5810	E5810
300	224	E5010	E5010	E5810	E5810
350	261	E5010	E5010	E5810	E5810
400	298	–	E5810	E5810	E5810
450	336	–	E5810	E5810	–
500	373	–	E5810	–	–

Baldor Explosion Proof AC and DC Motors North American Certifications

Baldor Explosion Proof Motors for the North American Marketplace

In the North American marketplace, Baldor uses Underwriters Laboratories (U.L.) and the Canadian Standards Association (CSA) as certifying bodies to approve and label our electric motors for use in Division based hazardous locations per NFPA70 National Electric Code (NEC) and C22.1, the Canadian Electric Code. Baldor explosion proof motors may be marked with one or more of the following:



UL Listing mark for use in the United States. Products with this mark have been evaluated to U.S. safety requirements.



CSA Listing mark for use in Canada and the United States. The product is certified to the applicable American and Canadian standards



CSA Listing mark for use in Canada. The product is certified to the applicable Canadian standards

Hazardous Area Classifications

Division - defines how often the potentially explosive materials are present during normal operating conditions.

Division 1: Ignitable concentrations are present all or most of the time

Division 2: Ignitable concentrations are not likely to be present during normal operation

Classes and Groups - define the type of potentially explosive atmosphere and the specific materials it contains.

Hazard Class	Groups per NEC 500	Substance
Class I Flammable Gases / Vapors / Liquids	Group A	Acetylene
	Group B	Hydrogen
	Group C	Ethylene
	Group D	Propane
Class II Combustible Dusts	Group E	Metal Dust
	Group F	Coal Dust
	Group G	Grain Dust
Class III Ignitable Fibers & Flyings	Not divided into Groups. 165°C maximum temperature limit for all Class III equipment not subject to overloading. 120°C maximum temperature limit for all equipment subject to overloading	

Surface temperatures

The "T" Code identifies the maximum absolute motor surface temperature that will be developed under all conditions of operation, and is chosen to be below the ignition temperature of the potential explosive material in the hazardous area. Surface temperatures of Baldor Explosion-Proof Motors will not exceed the following UL and CSA maximums under fault conditions.

T Code	Maximum Motor Surface Temperature		T Code (Continued)	Surface Temperature	
	°C	°F		°C	°F
T1	450	842	T3A	180	356
T2	300	572	T3B	165	329
T2A	280	536	T3C	160	320
T2B	260	500	T4	135	275
T2C	230	446	T4A	120	248
T2D	215	419	T5	100	212
T3	200	392	T6	85	185

Baldor Explosion Proof AC and DC Motors

North American Certifications

Baldor Division 1, Class & Group Stock ratings

All Baldor Division 1, stock motor ratings will have a red circle symbol next to the catalog # that indicates the explosion proof Class and Group the motor is certified to meet.

XP Class & Group Symbol	Description
1	Class 1, Group D
2	Class 1, Group D, Class 2, Group F & G
3	Class 1, Group D, Class 2, Group E, F & G
4	Class 1, Group C & D
5	Class 1, Group C & D, Class 2, Group F & G

Thermal Protection

As required by UL and CSA, explosion proof motors with Class II, Group F&G approvals must have over temperature protection. Internally mounted automatic thermal overloads (ATO's) are used on motors 1.5hp and less. Explosion proof motors 1hp and larger without ATO's have thermostats built in for thermal protection. It is the installer's responsibility to make sure that these devices are properly connected to a suitable switching device.

Inverter Duty Applications

Only Explosion proof motors which are specifically approved and UL listed for use on adjustable frequency drives can be used on inverters. See Pages 27 to 30 in this brochure for more information.

Ambient Temperatures

Stock explosion proof motors are suitable for applications in temperatures from -25°C (-13°F) to +40°C (+104°F). Custom motor designs are available for applications in temperatures between -25°C and -60°C and above +40°C. Contact your Baldor Sales office for further information.

Equivalent Zone Markings

NEC Article 505 and 506 define a North American System of Zone Classification for Gas & Dust. Most Baldor division based explosion proof motors 50hp and below, include these equivalent Zone Markings on the nameplate as standard. Equivalent zone markings can be added upon request to other ratings. Contact your local Baldor-Reliance sales office for assistance.

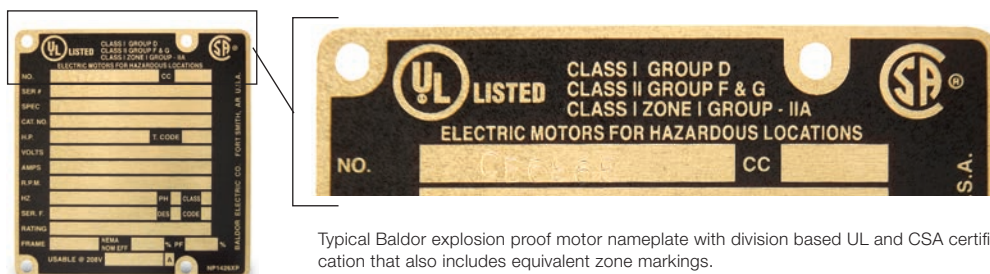

Typical Baldor explosion proof motor nameplate with division based UL and CSA certification that also includes equivalent zone markings.

Caution

Motors misapplied in hazardous environments can cause a fire or explosion resulting in destruction of property, serious injury or death. Only the end user or a qualified underwriter is to identify and select the proper class, group, division, and temperature code motor to meet the requirements of each installation. Baldor personnel, agents and distributors can advise what listings and approvals Baldor motors carry, but cannot evaluate nor recommend what motors may be suitable for use in hazardous environments.

Baldor Explosion Proof AC and DC Motors Outside North America Certifications

Baldor Custom Explosion Proof Motors for Outside North America

Baldor offers a wide variety of Custom Explosion Proof motors for use outside the US market where IEC based standards of certification are required.

Europe - ATEX Directive

IEC standards that have been adopted by countries in Europe are known as European Norms (EN). Directives (Laws) are issued by the European Union (EU) based on these EN standards. Equipment tested to EN standards bears a CE mark. The CE mark is a mandatory conformity mark for products placed on the market in the European Union. With the CE marking on a product, the manufacturer ensures that the product conforms to the essential requirements of the applicable EC directives.



Explosion Proof products that are placed on the European market must be certified to the ATEX directive (ATEX 94/9/EC). The objective of ATEX is to ensure the free movement of goods that are suitable for use in explosive atmospheres throughout the European Union. Offering one harmonized compliance procedure accepted by all EU countries eradicates the need for differing national standards. Baldor uses SIRA as our 3rd party Notified Body for ATEX certification.



Globally (Outside Europe) – IECEx System

The IECEx Scheme is the future route to global compliance certification. Its aim is to harmonize standards to allow free movement of goods by establishing a world-wide accepted standard. The IECEx scheme significantly reduces the need for re-testing and certification by conforming to international IEC standards, and therefore makes international trade easier, quicker and more cost effective.



All Baldor ATEX custom motors are dual labeled with our IECEx certification number to satisfy the broader international market.

Certificate of Conformity for Exports to Russia - GOST-R

GOST R certification is required for customs clearance in Russia and as an aid to sell or market the equipment within the country. Additionally, the RTN Use Permit (Rostechnadzor) allows the equipment to be installed and operated in Russia. Baldor is able to provide both of these upon request for all variants of our ATEX/IECEx product offering.



Typical ATEX Markings:

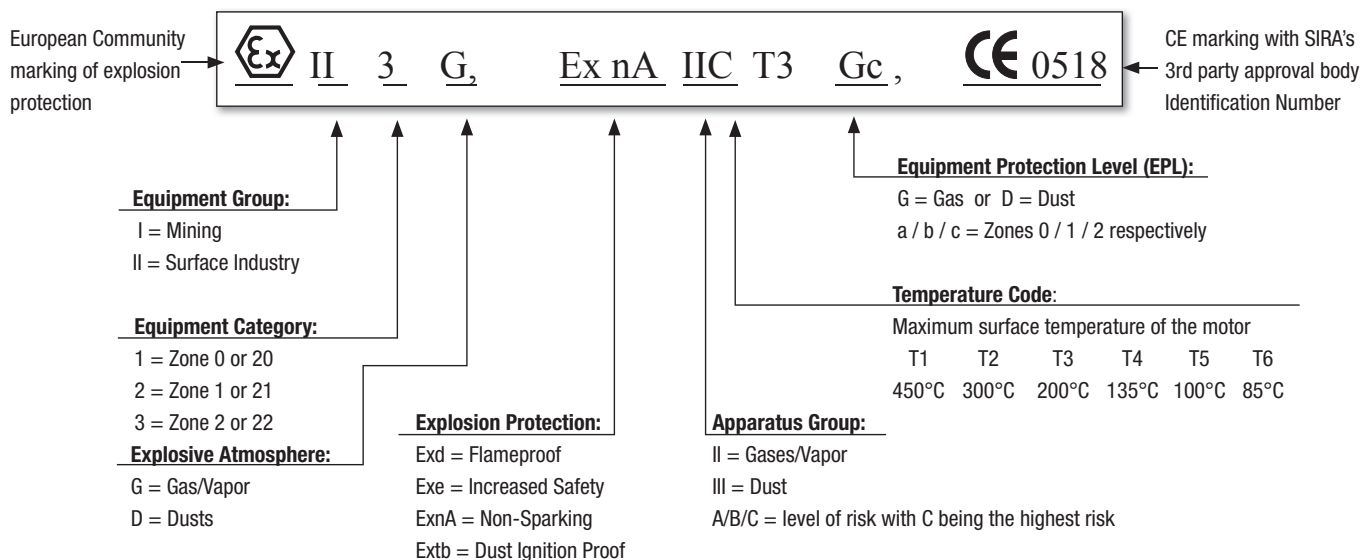

Baldor Explosion Proof AC and DC Motors Outside Nort America Certifications

Baldor Custom ATEX Capabilities Matrix - Group II (Surface Industry Applications)

Environment	Explosion Protection	Max. HP (kW)	NEMA Frame (IEC)	Max. Voltage	Apparatus Group	Temp Code	Ambient Temp. (°C)
Explosive Gas Environments (G)	Exd (Flameproof) IIB Zone 1	500HP (373kW)	143T – 449T (90M-280M)	1,000 volts	IIA & IIB	T3, T4 & T5	-20 to +40 (+65 Max)
	ExnA (Non-Sparking) Zone 2	450HP (335kW)	180T – 4412T (112M-280H)	2,300 volts	IIA, IIB & IIC	T2, T3 & T4	-20 to +40 (-30 Min)
Explosive Dust Environments (D)	Extb (Dust Ignition Proof) IIC Zone 21	500HP (373kW)	143T – 449T (90M-280M)	1,000 volts	IIIA, IIIB & IIC	T3, T4 & T5	-20 to +40 (+65 Max)
	Baldor motors marked “Extb” for Zone 21 may be additionally labeled “suitable for Zone 22 (EPL Dc)”						
Dual Protection Gas & Dust Environments (G/D)	Baldor ATEX motors can be dual labeled for “Exd” (Flameproof) and “Extb” (Dust Ignition Proof), Zones 1, 21 to meet the most hazardous explosive atmosphere applications.						
Increased Safety	“Exd” motors 180-449T, 112M-280H can be supplied with an Increased Safety conduit box separately labeled “Exe”						

Baldor takes pride in tailoring our custom motors to fit our customer’s specific requirements. For a full range of available options, pricing and availability contact your local Baldor Representative.

ABB IEC motors

ABB IEC motors are available in a wider range of explosion proof configurations and in larger power ratings. Information is available at www.abb.com/motors&generators or you may contact your local Baldor•Reliance office for assistance.

Caution

Motors misapplied in hazardous environments can cause a fire or explosion resulting in destruction of property, serious injury or death. Only the end user or a qualified underwriter is to identify and select the proper class, group, division, and temperature code motor to meet the requirements of each installation. Baldor personnel, agents and distributors can advise what listings and approvals Baldor motors carry, but cannot evaluate nor recommend what motors may be suitable for use in hazardous environments.

Baldor Explosion Proof AC and DC Motors

Motor Performance Data and Dimensions

Explosion Proof Motors – Reliability and Performance in Division 1 Applications

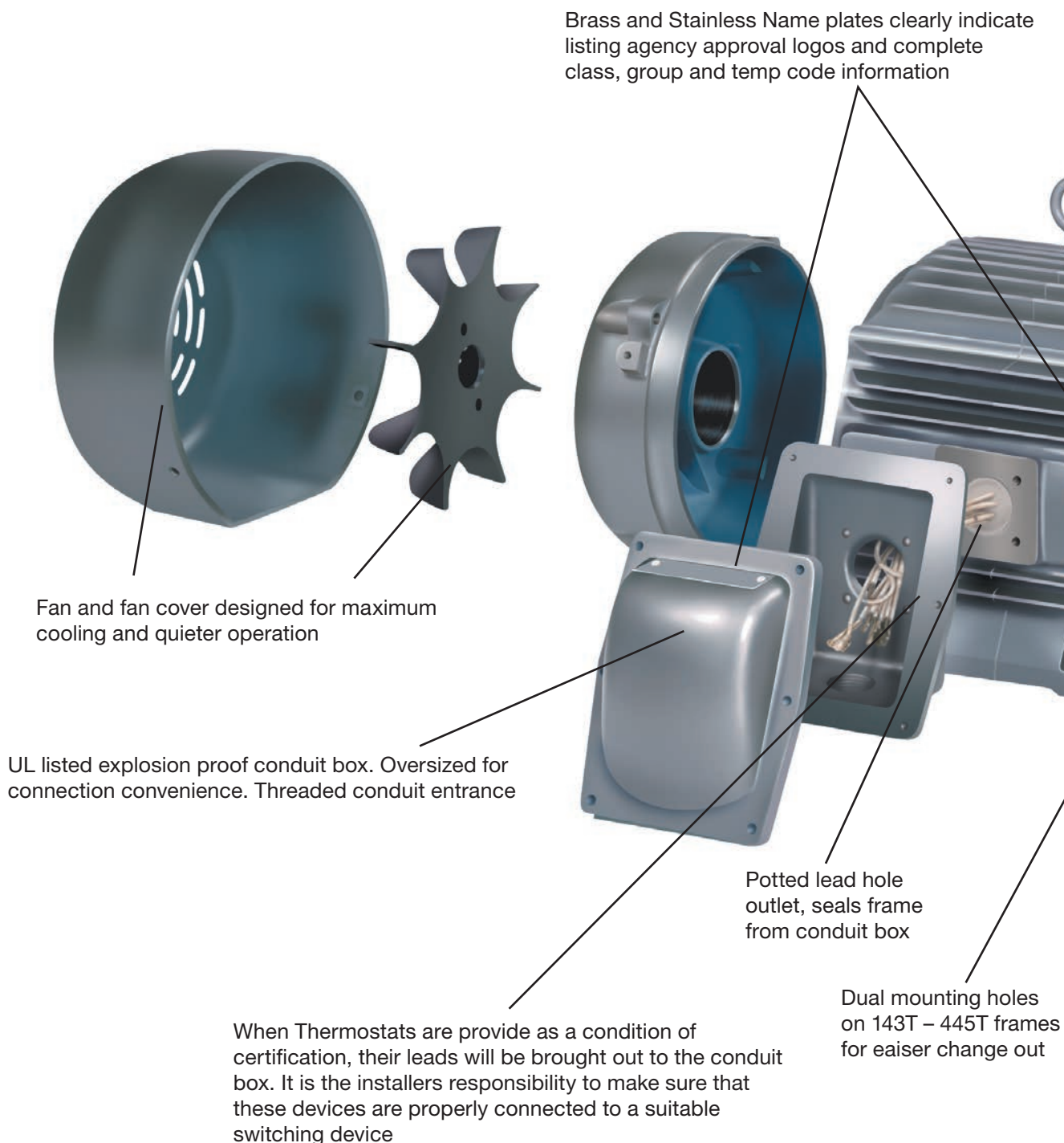

Baldor Explosion Proof AC and DC Motors

Motor Performance Data and Dimensions

Heavy Duty Frame construction is designed to contain maximum internal explosion pressure and maintain external surface temperatures below the minimum ignition temperature of the environment

Precision cast aluminum rotor minimizes vibration for long service life. Coated to prevent corrosion

Cast iron endplates and fancover standard – 250T-up (standard on all cast iron frame motors) with long flame paths. Die cast aluminum endplates with steel bearing insert standard on most steel band motors.

Longer rabbit feeds on frame and endplates provide stronger construction and longer flamepaths

Bearing retainers on pulley end of all C-face motors – allows vertical operation

Superior winding electrical designs with low temperature rises, minimize surface temperatures and provide long life even under thermal blanket effects of dust build up on frame

Close machine toleranced on inner cap and shaft clearance/seals provide proper flamepaths and prevent ingress of contamination into the bearings

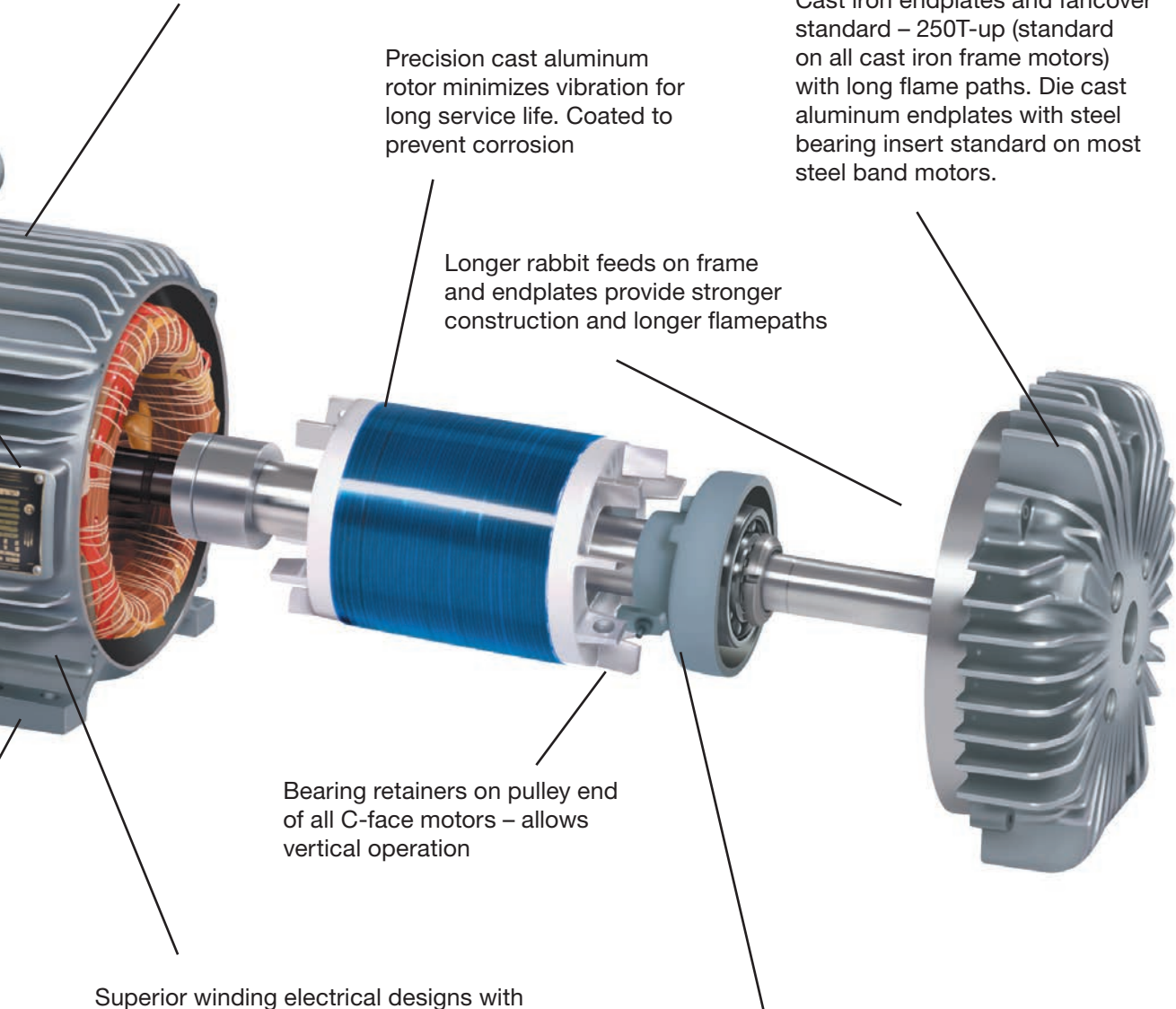

Baldor Explosion Proof AC and DC Motors

Motor Performance Data and Dimensions

Single Phase and Three Phase Explosion-Proof Motors with Rigid Base

These motors are ideal for a wide variety of applications where hazardous fumes or dust may be present. Available from stock in 1/4 hp though 300 hp, in NEMA frames 48 through 449T. U.L. and CSA approved for Division 1, Class I, Group D; Class I, Group D, Class II, Group F & G; Class I, Group C & D, Class II, Group F & G. 1.0 Service Factor.



Performance Data, Single Phase, Foot Mounted

Hp	kW	RPM	NEMA Frame	Catalog Number	XP Cls & Grp	XP Temp Code	Amps @ High V		Full Load Torque Lb. Ft.	Efficiency %			Power Factor %			Voltage	"C" Dim.	Conn. Diag. Number	Notes
							Full Load	Locked Rotor		1/2	3/4	Full Load	1/2 PF	3/4 PF	Full Load PF				
0.25	0.18	1725	48	L4003A	②	T3C	2.5	11	0.781	42.2	50	55	45	53	57	115/208-230	12.85	CD0885	-
			56	L5000A	②	T3C	2.1	10.8	0.762	50	60.6	62	47	54	64	115/208-230	13.22	CD0565	-
			56	L5000A-C	⑤	T3C	2.1	10.8	0.762	50	60.6	62	47	54	64	115/208-230	13.22	CD0565	-
0.33	0.25	1725	3450	L4005A	②	T3C	3	14	0.52	46.9	53.8	55	47	56	68	115/230	12.85	CD0565	-
			48	L4006A	②	T3C	3	13	1	41	52	60	41	52	60	115/208-230	12.85	CD0565	-
			56	L5001A	②	T3C	3	13	1	41	52	60	41	52	60	115/208-230	13.22	CD0565	-
0.5	0.37	1725	1140	L5002A	②	T4	3.4	13	1.5	41.5	50.1	54	42	50	56	115/230	14.3	CD0008	-
			3450	L5003A	②	T3C	3.7	18.5	0.75	49.7	57.4	57	49	61	71	115/230	13.22	CD0565	-
			48	L4009A	②	T3C	3.7	19.41	1.5	55.2	62	64	48	59	66	115/208-230	13.85	CD0565	-
			56	L5004A	②	T3C	3.7	19.41	1.5	55.2	62	64	48	59	66	115/208-230	14.22	CD0565	-
0.75	0.56	1725	56	L5004A-C	⑤	T3C	3.7	19.41	1.5	55.2	62	64	48	59	66	115/208-230	14.22	CD0565	-
			1140	L5005A	②	T4	4	19	2.25	57	62.3	59	41	49	63	115/230	15.17	CD0008	-
			3450	L5006A	②	T4	4.9	28.3	1.13	50	58	62	60	70	75	115/230	14.3	CD0008	-
			56	L5007A	②	T4	5.3	34	2.25	58.2	65.4	66	45	56	68	115/230	15.17	CD0008	-
1	0.75	1725	56	L5007A-C	⑤	T4	5.3	34	2.25	58.2	65.4	66	45	56	68	115/230	15.17	CD0008	-
			1140	L5022	①	T2C	5.7	24.3	3.43	57.6	61.8	59.5	48	59	74	115/208-230	16.04	CD0001	-
			3450	L5009A	②	T4	6	37.9	1.51	63.2	68.3	66	66	76	81	115/230	15.17	CD0008	-
			56	L5023A	②	T2C	6.5	37	3	63	66.8	67	53	65	73	115/230	15.17	CD0008	-
1.5	1.12	1725	143T	L5023T	①	T2C	6.4	39	3	67.6	70	67	53	67	73	115/208-230	15.23	CD0001	-
			1140	L5026	②	T3C	7	34	4.6	62.6	68.5	67	48	59	67	115/208-230	16.92	CD0001	-
			3450	L5030T	②	T3C	7.5	42	2.3	65.3	68.4	70	64	73	82	115/208-230	15.23	CD0001	-
2	1.5	1725	184	L5013	②	T3C	9.5	68	4.5	66.9	72.6	70	50	61	70	115/230	16.92	CD0001	-
			3450	L5031T	②	T3C	11.5	78	3	64.2	70.5	74	65	75	82	115/208-230	16.11	CD0001	-
3	2.2	1725	145T	L5027T	①	T2C	11	61	6	72.3	74.3	75	58	69	81	115/230	17.42	CD0001	-
			184T	L5028T	①	T2C	14.5	86	4.5	71	73.5	76	83	88	87	115/230	17.42	CD0001	-
5	4	1725	215	L5018	②	T3C	15	90	9	75	79.1	79	61	72	77	115/230	19.49	CD0076	-
			184T	L5020	①	T2C	21	139	15.1	84.1	85.7	84	87	91	92	230	19.9	CD0017A02	-

- ① Class I, Group D
- ② Class I, Group D, Class II, Group F & G
- ⑤ Class I, Group C & D, Class II, Group F & G

CAUTION: These Explosion-proof motors are not suitable for use with adjustable speed drives. Inverter Duty Explosion-proof motors must be used, see page 27.

Baldor Explosion Proof AC and DC Motors

Motor Performance Data and Dimensions

Three Phase, Foot Mounted (continued)

Hp	KW	RPM	NEMA Frame	Catalog Number	XP Cls & Grp	XP Temp Code	Amps @ High V		Full Load Torque Lb. Ft.	Efficiency %			Power Factor %			Voltage	"C" Dim.	Conn. Diag. Number	Notes
							Full Load	Locked Rotor		1/2	3/4	Full Load	1/2 PF	3/4 PF	Full Load PF				
0.25	0.18	1725	48	M6002A	②	T3C	0.65	3.45	0.75	55.5	62.5	63	33	43	56	208-230/460	12.85	CD0007	-
0.33	0.25	1725	56	M7002A	②	T3C	0.8	4.4	1	59	65	67	40	50	57	208-230/460	13.22	CD0007	-
0.33	0.25	1140	56	M7003A	②	T4	0.8	4.1	1.5	58	64	70	39	48	57	208-230/460	14.36	CD0007	-
0.5	0.37	3450	56	M7005A	②	T3C	1.1	6	0.75	56.3	64	68	44	56	63	208-230/460	13.22	CD0007	-
0.5	0.37	1725	48	M6007A	②	T3C	1	6.7	1.5	65	71.7	74	39	51	63	208-230/460	12.85	CD0007	-
0.5	0.37	1725	56	M7006A	②	T3C	1	6.7	1.5	65	71.1	74	39	51	63	208-230/460	13.22	CD0007	-
0.5	0.37	1140	56	M7007A	②	T4	1.2	5.8	2.25	57	64	70	37	47	55	208-230/460	14.36	CD0007	-
0.75	0.56	3450	56	M7009A	②	T3C	1.3	7.6	1.2	70.6	73.6	75	58	67	73	208-230/460	13.22	CD0007	-
0.75	0.56	1725	56	M7010A	②	T3C	1.5	10	2.25	69.7	74.7	73	42	55	58	208-230/460	14.22	CD0007	-
0.75	0.56	1140	56	M7031A	②	T4	1.4	8	3.4	71.1	75	77	44	55	63	208-230/460	15.23	CD0007	-
0.75	0.56	1140	143T	M7031TA	②	T4	1.4	8	3.4	71.1	75	77	44	55	63	208-230/460	15.23	CD0007	-
1	0.75	3450	56	M7013	②	T3C	1.8	11	1.5	72.1	76.8	75.5	53	68	71	208-230/460	13.22	CD0005	-
1	0.75	1740	56	M7014	②	T3C	1.8	12.4	2.99	68	73.6	75.5	45	57	67	208-230/460	14.3	CD0005	19
1	0.75	1760	143T	EM7014T	②	T3C	1.5	12.1	2.97	81.9	84.8	85.5	49	62	71	230/460	15.23	CD0005	19
1	0.75	1760	143T*	EM7114T	②	T3C	1.5	12.1	2.97	81.9	84.8	85.5	49	62	71	230/460	16.28	CD0005	19
1	0.75	1760	143T*	EM7114T-C	⑤	T4	1.5	12.1	2.97	81.9	84.8	85.5	49	62	70	230/460	16.28	CD0005	19
1	0.75	1750	182	M7015	②	T3C	1.6	13.2	2.99	78	81.4	82.5	50	63	73	230/460	15.23	CD0005	19
1	0.75	1155	56	M7032	①	T2C	1.9	10.3	4.5	73.9	77.8	78.5	41	54	63	230/460	15.17	CD0005	-
1	0.75	1155	145T	EM7032T	②	T3C	1.8	10.8	4.51	79.4	82.3	82.5	43	55	64	230/460	17.48	CD0005	19
1.5	1.12	3500	143T	EM7018T	②	T3C	1.9	17.9	2.22	82	84.6	84	67	79	85	230/460	14.36	CD0005	19
1.5	1.12	1735	56	M7034	②	T3C	2.3	17.5	4.5	77.3	80.9	81.5	51	65	74	208-230/460	14.3	CD0005	19
1.5	1.12	18760	145T	EM7034T	②	T3C	2.2	18.3	4.47	84.5	86.9	86.5	51	65	73	230/460	16.1	CD0005	19
1.5	1.12	1765	145T*	EM7134T	②	T3C	2.3	20.7	4.54	83.8	86.4	86.5	49	62	71	208-230/460	16.28	CD0005	-
1.5	1.12	1765	145T*	EM7134T-C	⑤	T4	2.3	20.7	4.54	83.8	86.4	86.5	49	62	76	208-230/460	16.28	CD0005	-
1.5	1.12	1755	184	M7019	②	T3C	2.4	19	4.43	79.4	83	84	48	62	70	230/460	15.23	CD0005	19
1.5	1.12	1170	182T	EM7020T	②	T3C	2.6	14.7	6.8	86	88.3	87.5	42	53	61	230/460	17.42	CD0005	19
1.5	1.12	1170	182T*	EM7120T	②	T3C	2.6	14.7	6.8	86	88.3	87.5	42	53	0	230/460	18.24	CD0005	19
2	1.5	3490	143T	EM7071T	②	T3C	2.5	25.9	2.98	83.5	85.9	85.5	75	84	88	230/460	16.1	CD0005	19
2	1.5	1735	56	M7037	②	T3C	3	24.8	6.05	79.2	82.2	82.5	53	67	76	208-230/460	15.17	CD0005	-
2	1.5	1755	145T	EM7037T	②	T3C	2.9	24.3	5.95	84	86.5	86.5	51	64	73	230/460	16.1	CD0005	19
2	1.5	1750	145T*	EM7137T	②	T3C	2.9	25	5.95	85.1	87.1	86.5	53	66	75	230/460	16.28	CD0005	19
2	1.5	1750	145T*	EM7137T-C	⑤	T3C	2.9	25	5.95	85.1	87.1	86.5	53	66	75	208-230/460	16.28	CD0005	-
2	1.5	1750	184	M7023	②	T3C	3.1	23.8	5.96	81	83.6	84	50	63	72	230/460	15.23	CD0005	19
2	1.5	1170	184T	EM7041T	②	T3C	3.5	20.9	9	86.7	88.6	88.5	41	52	61	230/460	18.92	CD0005	19
3	2.2	3450	145T	EM7075T	①	T3C	3.6	33	4.5	87.9	88.2	86.5	81	88	92	230/460	17.48	CD0005	-
3	2.2	3450	182T	EM7026T	②	T3C	3.7	33.3	4.7	86.2	87.3	86.5	82	88	91	230/460	16.05	CD0005	19
3	2.2	3460	182T*	EM7126T	②	T3C	3.8	30.9	4.73	86.5	87.4	86.5	76	84	87	230/460	17.56	CD0005	19
3	2.2	3460	184	M7026	②	T3C	3.7	30.5	4.7	84.9	86.2	85.5	80	88	91	230/460	15.55	CD0005	19
3	2.2	1760	182T	EM7042T	②	T3C	4.2	30.8	7.1	86	88.5	89.5	49	62	75	230/460	18.92	CD0005	19
3	2.2	1755	182T*	EM7142T	②	T3C	4.1	29.8	9.06	88.9	90.1	89.5	58	70	77	230/460	17.56	CD0005	19
3	2.2	1760	182T*	EM7142T-C	⑤	T4	4	31.69	8.93	89	90	89.5	62	73	80	230/460	17.56	CD0005	19
3	2.2	1770	213	M7027	②	T3C	4.1	34.5	8.87	85.4	87.7	87.5	58	71	77	230/460	16.44	CD0005	19
3	2.2	1160	213T	EM7036T	②	T3C	4.6	34.4	13.4	87.7	89.4	89.5	49	61	68	230/460	20.32	CD0005	19

* Cast Iron Frame

① Class I, Group D

② Class I, Group D, Class II, Group F & G

⑤ Class I, Group C & D, Class II, Group F & G

19 60/50 Hertz motor. 60 Hertz data shown,

contact your local Baldor•Reliance office for 50 Hertz data.

CAUTION: These Explosion-proof motors are not suitable for use with adjustable speed drives. Inverter Duty Explosion-proof motors must be used, see page 27.

Baldor Explosion Proof AC and DC Motors

Motor Performance Data and Dimensions

Three Phase, Foot Mounted (continued)

Hp	kW	RPM	NEMA Frame	Catalog Number	XP Cls & Grp	XP Temp Code	Amps @ High V		Full Load Torque Lb. Ft.	Efficiency %			Power Factor %			Voltage	"C" Dim.	Conn. Diag. Number	Notes
							Full Load	Locked Rotor		1/2	3/4	Full Load	1/2 PF	3/4 PF	Full Load PF				
5	4	3450	184T	EM7072T	②	T3C	5.9	57.2	7.67	88.9	89.4	88.5	81	88	91	230/460	18.12	CD0005	19
5	4	3475	184T*	EM7172T	②	T3C	6.3	51.7	7.5	87.8	89	88.5	64	77	84	230/460	17.56	CD0005	19
5	4	1750	184T	EM7044T	②	T3C	6.7	49.1	14.9	89.7	90.3	89.5	60	72	78	230/460	18.92	CD0005	19
5	4	1750	184T*	EM7144T	②	T3C	6	45.5	15	89.6	89.6	89.5	62	74	79	230/460	17.56	CD0005	19
5	4	1750	184T*	EM7144T-C	⑤	T4	6	45.5	15	89.6	89.6	89.5	62	74	79	230/460	17.56	CD0005	19
5	4	1760	215	M7030	②	T3C	6.6	49.6	14.8	62	74	87.5	62	74	79	230/460	18.06	CD0005	19
5	4	1160	215T	EM7040T	②	T3C	7.3	51.6	22.7	89.8	90.4	89.5	55	66	72	230/460	22.32	CD0005	19
7.5	5.6	3450	184T	EM7073T	①	T2C	8.4	91	11.4	90.6	90.7	89.5	85	90	93	230/460	18.92	CD0005	-
7.5	5.6	3525	213T	EM7045T	②	T3C	8.6	63.1	11.1	89.1	90.2	89.5	80	87	90	230/460	19.57	CD0005	19
7.5	5.6	3525	213T*	EM7145T	②	T3C	8.6	75	11.2	90	91.4	90.2	79	87	90	230/460	19.9	CD0005	19
7.5	5.6	1770	213T	EM7047T	②	T3C	9.4	69.3	17.8	90.8	91.9	91.7	56	70	81	230/460	19.57	CD0005	19
7.5	5.6	1770	213T*	EM7147T	②	T3C	9.5	68	22.1	91.6	92.3	91.7	65	76	81	230/460	19.9	CD0005	19
7.5	5.6	1770	213T*	EM7147T-C	⑤	T4	9.5	68	22.1	91.6	92.3	91.7	65	76	81	230/460	19.91	CD0005	19
7.5	5.6	1180	254T*	EM7048T	②	T3C	10.7	67	32.4	89.3	90.7	91	53	64	70	230/460	25.5	CD0005	19
10	7.5	3500	215T	EM7074T	①	T2C	11.2	117	15	90.8	92.3	91.7	84	90	92	230/460	20.82	CD0005	-
10	7.5	3500	215T*	EM7174T	②	T3C	11.1	88.5	14.9	93	93.2	92.4	79	88	90	230/460	19.31	CD0005	-
10	7.5	1770	215T	EM7070T	②	T3C	12	103	29.5	92.1	92.4	91.7	66	79	85	230/460	22.32	CD0005	19
10	7.5	1760	215T*	EM7170T	②	T3C	12.2	81	29.8	92.5	92.9	91.7	71	80	83	230/460	19.9	CD0005	19
10	7.5	1760	215T*	EM7170T-C	⑤	T3C	12.2	81	29.8	92.5	92.9	91.7	71	80	83	230/460	19.91	CD0005	19
10	7.5	1180	256T*	EM7065T	②	T3C	14.6	95.3	44.4	89.8	91.4	91	52	63	70	230/460	25.5	CD0005	19
15	22.4	3520	254T*	EM7053T	②	T3C	17.5	110	22.1	91	91.6	91	77	85	87	230/460	25.5	CD0180	19
15	22.4	1765	254T*	EM7054T	②	T3C	18	125	45	92.1	93	92.4	71	81	84	230/460	25.5	CD0005	19
15	22.4	1765	254T*	EM7054T-C	⑤	T4	18	125	45	92.1	93	92.4	71	81	84	230/460	25.5	CD0005	19
15	22.4	1180	284T*	EM7057T	②	T3C	20	122	65.7	90.6	92	91.7	58	69	75	230/460	28.61	CD0180	19
20	15	3520	256T*	EM7059T	②	T3C	23	161	29.6	92.2	92.4	91	78	86	89	230/460	25.5	CD0005	19
20	15	1765	256T*	EM7056T	②	T3C	24	166	54.1	92.5	93.2	93	72	81	84	230/460	25.5	CD0180	19
20	15	1765	256T*	EM7056T-C	⑤	T4	24	166	54.1	92.5	93.2	93	72	81	84	230/460	25.5	CD0180	19
20	15	1180	286T*	EM7079T	②	T3C	27	165	89.4	91.1	91.9	91.7	60	71	77	230/460	28.61	CD0180	19
25	18.7	3520	284T*	EM7063T	②	T3C	28.5	177	37.4	91.5	91.7	91.7	80	87	89	230/460	27.24	CD0180	19
25	18.7	1780	284T*	EM7058T	②	T3C	30.5	179	71.2	91.5	92.2	93.6	69	79	82	230/460	28.61	CD0005	19
25	18.7	1780	284T*	EM7058T-C	⑤	T4	30.5	179	71.2	91.5	92.2	93.6	69	79	82	230/460	28.61	CD0005	19
25	18.7	1180	324T*	EM7082T	②	T3C	32	198	111	92.8	93.5	93	65	75	79	230/460	32	CD0180	19
30	22.4	3520	286T*	EM7083T	②	T3C	33	194	44.6	92.9	93.3	91.7	85	90	90	230/460	27.24	CD0180	19
30	22.4	1770	286T*	EM7060T	②	T3C	36	235	89.1	93.7	94.3	93.6	66	75	83	230/460	28.61	CD0005	19
30	22.4	1780	286T*	EM7060T-C	⑤	T4	37	216	90	93.5	94.1	93.6	67	78	82	230/460	28.61	CD0005	19
30	22.4	1180	326T*	EM7080T	②	T3C	39	243	133	92.5	93.2	93	62	73	78	230/460	32	CD0005	19
40	29	3530	324T*	EM7067T	②	T3C	46	299	53.3	88.1	89.8	92.4	78	85	88	230/460	30.5	CD0180	19
40	29	1775	324T*	EM7062T	②	T3C	48	334	118	93.6	94.4	94.1	67	77	82	230/460	32	CD0180	19
40	29	1775	324T*	EM7062T-C	⑤	T4	48	334	118	93.6	94.4	94.1	67	77	82	230/460	32.12	CD0180	19
40	20	1180	364T*	EM7084T	②	T3C	47.2	275	178	94.4	94.5	94.1	74	81.5	84.3	230/460	33.44	416820-002	19
50	37	3540	326T*	EM7081T	②	T3C	56	408	74.4	93.8	94.2	93	82	88	90	230/460	30.5	CD0180	19
50	37	1775	326T*	EM7064T	②	T3C	57	392	149	94.4	94.9	94.5	73	82	87	230/460	32	CD0180	19
50	37	1775	326T*	EM7064T-C	⑤	T4	57	392	149	94.4	94.9	94.5	73	82	87	230/460	32.12	CD0180	19
50	37	1180	365T*	EM7085T	②	T4	60.1	358	222	94.4	94.6	94.1	70.9	79.4	82.7	230/460	33.44	416820-002	19

* Cast Iron Frame

① Class I, Group D

② Class I, Group D, Class II, Group F & G

⑤ Class I, Group C & D, Class II, Group F & G

19 60/50 Hertz motor. 60 Hertz data shown, contact your local Baldor•Reliance office for 50 Hertz data.

35 Design A, Exceeds Design B in rush limits

CAUTION: These Explosion-proof motors are not suitable for use with adjustable speed drives. Inverter Duty Explosion-proof motors must be used, see page 27.

Baldor Explosion Proof AC and DC Motors

Motor Performance Data and Dimensions

Three Phase, Foot Mounted (continued)

Hp	kW	RPM	NEMA Frame	Catalog Number	XP Cls & Grp	XP Temp Code	Amps @ High V		Full Load Torque Lb. Ft.	Efficiency %			Power Factor %			Voltage	"C" Dim.	Conn. Diag. Number	Notes
							Full Load	Locked Rotor		1/2	3/4	Full Load	1/2 PF	3/4 PF	Full Load PF				
60	44	1780	364T*	EM7066T	②	T4	68	430	177	95.2	95.3	95	78.7	85	87	230/460	33.44	416820-002	19
60	44	1780	364T*	EM7066T-C	⑤	T4	68	430	177	95.2	95.3	95	78.7	85	87	230/460	33.44	416820-002	19
60	44	1185	404T*	EM7086T	②	T4	67.3	434	266	94.6	94.9	94.5	79.3	86	88.3	230/460	38.31	416820-002	19
75	56	1780	365T*	EM7068T	⑤	T4	84.1	510	221	96.1	95.9	95.4	78.2	85.1	87.5	230/460	33.44	416820-002	19
75	56	1185	405T*	EM7087T	②	T4	84.2	537	333	94.8	95	94.5	79.3	85.9	88.3	230/460	38.31	416820-002	19
100	75	1780	405T*	EM7090T	⑤	T4	112	708	295	95.5	95.7	95.4	77.9	84.9	87.5	230/460	38.31	416820-002	19
125	93	1780	444T*	EM74124T-4	⑤	T4	139	907	368	94.5	95.3	95.4	81.7	87.4	88.5	460	44.62	416820-036	19
150	112	1785	447T*	EM74154T-4	⑤	T4	164	1075	441	95.6	96	95.8	86	89.1	89.2	460	47.83	416820-036	19
200	149	1785	449T*	EM74204T-4	⑤	T4	216	1387	588	96.1	96.4	96.2	88.9	90.4	89.9	460	52.83	416820-036	19
250	187	1785	447T*	M74254T-4	⑤	T4	281	1783	738	94.6	95.2	95	82.2	86.9	87.6	460	47.83	416820-036	19
300	224	1785	449T*	M74304T-4	⑤	T4	328	2191	883	95.3	95.9	95.8	86.5	89.4	89.3	460	52.83	416820-036	19

Three Phase, 575V, Foot Mounted

Hp	kW	RPM	NEMA Frame	Catalog Number	XP Cls & Grp	XP Temp Code	Amps @ High V		Full Load Torque Lb. Ft.	Efficiency %			Power Factor %			Voltage	"C" Dim.	Conn. Diag. Number	Notes
							Full Load	Locked Rotor		1/2	3/4	Full Load	1/2 PF	3/4 PF	Full Load PF				
0.5	0.37	1725	56	M7006-5	②	T3C	0.9	5.9	1.5	59	66.7	74	41	52	60	575	14.3	CD0006	-
0.75	0.56	1725	56	M7010-5	②	T3C	1.2	6.7	2.3	64	70.4	76	46	58	69	575	14.3	CD0006	-
1	0.75	3450	56	M7013-5	②	T3C	1.2	8.8	1.5	72.1	76.8	75.5	53	68	76	575	13.22	CD0006	-
1	0.75	1740	56	M7014-5	②	T3C	1.5	9.57	2.99	67.4	72.9	75.5	45	57	67	575	14.3	CD0006	-
1	0.75	1760	143T	EM7014T-5	②	T3C	1.2	9.66	2.97	81.9	84.8	85.5	49	62	71	575	14.36	CD0006	-
1.5	1.12	3500	143T	EM7018T-5	②	T3C	1.5	14.5	2.22	82.1	84.3	84	66	78	85	575	14.36	CD0006	-
1.5	1.12	1760	145T	EM7034T-5	②	T3C	1.8	14.6	4.47	84.5	87	86.5	51	65	73	575	15.23	CD0006	-
2	1.5	3490	145T	EM7071T-5	②	T3C	2	21	2.98	83.6	85.5	85.5	74	84	88	575	15.23	CD0006	-
2	1.5	1755	145T	EM7037T-5	②	T3C	2.4	19.6	5.95	83.8	86.4	86.5	50	64	73	575	16.1	CD0006	-
3	2.2	1760	182T	EM7042T-5	②	T3C	3.3	25.9	8.88	87.7	89.5	89.5	54	67	75	575	17.42	CD0006	-
5	4	3450	184T	EM7072T-5	②	T3C	4.7	45.7	7.64	88.4	89.1	88.5	81	88	91	575	18.12	CD0006	35
5	4	1750	184T	EM7044T-5	②	T3C	5.3	39.3	14.9	89.6	90.5	89.5	60	72	78	575	18.12	CD0006	-
7.5	5.6	1770	213T	EM7047T-5	②	T3C	7.6	58.5	22.2	91.1	92.3	91.7	61	74	81	575	20.32	CD0006	35
10	7.5	1760	215T*	EM7170T-5	②	T3C	9.8	66.3	29.8	92.1	92.7	91.7	70	79	83	575	19.9	CD0006	-
15	11	1765	254T*	EM7054T-5	②	T3C	14.8	99	44.5	91.3	92.5	92.4	67	78	82	575	25.5	CD0006	-
20	15	1765	256T*	EM7056T-5	②	T3C	19.2	140	59	92.8	93.2	93	72	78	84	575	25.5	CD0006	-
25	18.7	1780	284T*	EM7058T-5	②	T3C	24.5	150	74	91	92.7	93.6	70	79	82	575	28.61	CD0006	-
30	22.4	1770	286T*	EM7060T-5	②	T3C	29	177	89.2	93.9	94.4	93.6	69	77	83	575	28.61	CD0006	-
40	29	1775	324T*	EM7062T-5	②	T3C	39	267	118	93.6	94.3	94.1	67	77	82	575	32	CD0006	-

* Cast Iron Frame

① Class I, Group D

② Class I, Group D, Class II, Group F & G

⑤ Class I, Group C & D, Class II, Group F & G

19 60/50 Hertz motor. 60 Hertz data shown,

contact your local Baldor•Reliance office for 50 Hertz data.

35 Design A, Exceeds Design B in rush limits

CAUTION: These Explosion-proof motors are not suitable for use with adjustable speed drives. Inverter Duty Explosion-proof motors must be used, see page 27.

Baldor Explosion Proof AC and DC Motors

Motor Performance Data and Dimensions

Single & Three Phase Explosion-Proof C-Face Motors

Baldor motors for use on pumps, blowers and valves that require a NEMA C-face mounting configuration. Installed where hazardous fumes or dust may be present. Positively locked drive end bearing. 1.0 Service Factor. Available from stock in single and three phase, 1/3 hp through 50 hp, in NEMA frames 56C through 326TC. UL and CSA approved for Division 1, Class I, Group D; Class I, Group D, Class II, Group F & G.



Single Phase, C-Face, Foot Mounted

Hp	kW	RPM	NEMA Frame	Catalog Number	XP Cls & Grp	XP Temp Code	Amps @ High V		Full Load Torque Lb. Ft.	Efficiency %			Power Factor %			Voltage	"C" Dim.	Conn. Diag. Number	Notes
							Full Load	Locked Rotor		1/2	3/4	Full Load	1/2 PF	3/4 PF	Full Load PF				
0.33	0.25	1725	56C	CL5001A	②	T3C	6/3.2-3	13	1	41	52	60	41	52	60	115/208-230	13.22	CD0565	-
0.5	0.37	3450	56C	CL5003A	②	T3C	7.4/3.7	18.5	0.75	49.7	57.4	57	49	61	71	115/230	13.22	CD0565	-
0.5	0.37	1725	56C	CL5004A	②	T3C	7.4/3.9-3.7	19.41	1.5	55.2	62	64	48	59	66	115/208-230	14.22	CD0565	-
0.75	0.56	1725	56C	CL5007A	②	T4	10.6/5.3	34	2.25	58.2	65.4	66	45	56	68	115/230	15.17	CD0008	-
1	0.75	3450	56C	CL5009A	②	T4	6-Dec	37.9	1.51	63.2	68.3	66	66	76	81	115/230	15.17	CD0008	-
1	0.75	1725	56C	CL5023A	②	T2C	13/6.5	74	3	63	66.8	67	53	65	73	115/230	15.17	CD0008	-
1.5	1.12	3450	143TC	CL5030T	②	T3C	15/7.9-7.5	42	2.3	65.3	68.4	70	64	73	82	115/208-230	15.23	CD0001	-
1.5	1.12	1725	184C	CL5013	②	T3C	19/9.5	68	4.5	66.9	72.6	70	50	61	70	115/230	16.93	CD0001	-
2	1.5	3450	143TC	CL5031T	②	T3C	23/12-11.5	78	3	64.2	70.5	74	65	75	82	115/208-230	16.1	CD0001	-
2	1.5	1725	182TC	CL5027T	①	T2C	22/11	61	6	72.3	74.3	75	58	69	81	115/230	18.86	CD0001	-
3	2.2	3450	184TC	CL5028T	①	T2C	29/14.5	86	4.5	71	73.5	76	83	88	87	115/230	18.86	CD0001	-
3	2.2	1725	215C	CL5018	①	T2C	30/15	90	9	75	79.1	79	61	72	77	115/230	19.56	CD0076	-
5	4	1725	215C	CL5020	①	T2C	21	139	15.1	84.1	85.7	84	87	91	92	230	20.69	CD0017A02	-

① Class I, Group D

② Class I, Group D, Class II, Group F & G

CAUTION: These Explosion-proof motors are not suitable for use with adjustable speed drives. Inverter Duty Explosion-proof motors must be used, see page 27.

Baldor Explosion Proof AC and DC Motors

Motor Performance Data and Dimensions

Three Phase, C-Face, Foot Mounted

Hp	kW	RPM	NEMA Frame	Catalog Number	XP Cls & Grp	XP Temp Code	Amps @ High V			Full Load Torque Lb. Ft.	Efficiency %			Power Factor %			Voltage	"C" Dim.	Conn. Diag. Number	Notes
							Full Load	Locked Rotor			1/2	3/4	Full Load	1/2 PF	3/4 PF	Full Load PF				
0.5	0.37	3450	56C	CM7005A	②	T3C	2.4-2.2/1.1	6	0.75	56.3	64	68	44	56	63	208-230/460	13.22	CD0007		
0.5	0.37	1725	56C	CM7006A	②	T3C	2.1-2/1	6.7	1.5	65	71.7	74	39	51	63	208-230/460	13.22	CD0007	-	
0.75	0.56	3450	56C	CM7009A	②	T3C	2.7-2.6/1.3	7.6	1.2	70.6	73.6	75	58	67	73	208-230/460	13.22	CD0007	-	
0.75	0.56	1725	56C	CM7010A	②	T3C	3.2-3/1.5	10	2.25	69.7	74.7	73	42	55	58	208-230/460	14.22	CD0007		
1	0.75	3450	56C	CM7013	②	T3C	3.7-3.6/1.8	11	1.5	72.1	76.8	75.5	53	68	71	208-230/460	13.22	CD0005	-	
1	0.75	1740	56C	CM7014	②	T3C	3.9-3.6/1.8	12.4	2.99	68	73.6	75.5	45	57	67	208-230/460	14.3	CD0005	19	
1	0.75	1760	143TC	CEM7014T	②	T3C	3/1.5	12.1	2.97	81.9	84.8	85.5	49	62	71	230/460	14.36	CD0005	19	
1.5	1.12	3500	143TC	CEM7018T	②	T3C	3.8/1.9	17.9	2.22	82	84.6	84	67	79	85	230/460	14.36	CD0005	19	
1.5	1.12	1735	56C	CM7034	②	T3C	5-4.6/2.3	17.5	4.5	77.3	80.9	81.5	51	65	74	208-230/460	14.3	CD0005	19	
1.5	1.12	1760	145TC	CEM7034T	②	T3C	4.4/2.2	18.3	4.47	84.5	86.9	86.5	51	65	73	230/460	15.23	CD0005	19	
2	1.5	3490	145TC	CEM7071T	②	T3C	5/2.5	25.9	2.98	83.5	85.9	85.5	75	84	88	230/460	15.23	CD0005	19	
2	1.5	1735	56C	CM7037	②	T3C	6.0/3.0	24.8	6.05	79.2	82.2	82.5	53	67	76	230/460	15.17	CD0005	19	
2	1.5	1755	145TC	CEM7037T	②	T3C	5.8/2.9	24.3	5.95	84	86.5	86.5	51	64	73	230/460	16.1	CD0005	19	
3	2.2	3450	145TC	CEM7075T	①	T3C	7.2/3.6	33	4.5	87.9	88.2	86.5	81	88	92	230/460	16.09	CD0005	-	
3	2.2	1760	182TC	CEM7042T	②	T3C	8.4/4.2	30.8	7.1	86	88.5	89.5	49	62	75	230/460	18.86	CD0005	19	
5	4	3450	184TC	CEM7072T	②	T3C	11.8/5.9	57.2	7.67	88.9	89.4	88.5	81	88	91	230/460	18.86	CD0005	19, 35	
5	4	1750	184TC	CEM7044T	②	T3C	13.4/6.7	49.1	14.9	89.7	90.3	89.5	60	72	78	230/460	19.55	CD0005	19	
7.5	5.6	3450	184TC	CEM7073T	①	T2C	16.8/8.4	91	11.4	90.6	90.7	89.5	85	90	93	230/460	20.36	CD0005	35	
7.5	5.6	3470	213TC	CEM7045T	②	T3C	17.2/8.6	63.1	11.1	89.1	90.2	89.5	80	87	90	230/460	20.33	CD0005	19	
7.5	5.6	1770	213TC	CEM7047T	②	T3C	18.8/9.4	69.3	17.8	90.8	91.9	91.7	56	70	81	230/460	21.08	CD0005	19, 35	
10	7.5	3500	215TC*	CEM7174T	②	T3C	22.2/11.1	88.5	14.9	93	93.2	92.4	79	88	90	230/460	20.65	CD0005	19	
10	7.5	1760	215TC*	CEM7170T	②	T3C	24.4/12.2	81	29.8	92.5	92.9	91.7	71	80	83	230/460	20.65	CD0005	19	
15	11	3520	254TC*	CEM7053T	②	T3C	35/17.5	110	22.1	91	91.6	91	77	85	87	230/460	26	CD0180	19	
15	11	1765	254TC*	CEM7054T	②	T3C	36/18	125	45	92.1	93	92.4	71	81	84	230/460	26	CD0005	19	
20	15	3520	256TC*	CEM7059T	②	T3C	46/23	161	29.6	92.2	92.4	91	78	86	89	230/460	26	CD0005	19	
20	15	1765	256TC*	CEM7056T	②	T3C	48/24	166	54.1	92.5	93.2	93	72	81	84	230/460	26	CD0180	19	
25	18.7	3520	284TSC*	CEM7063T	②	T3C	57/28.5	177	37.4	91.5	91.7	91.7	80	87	89	230/460	27.24	CD0180	19	
25	18.7	1780	284TC*	CEM7058T	②	T3C	61/30.5	179	71.2	91.5	92.2	93.6	69	79	82	230/460	28.61	CD0005	19	
30	22.4	1770	286TC*	CEM7060T	②	T3C	72/36	235	89.1	93.7	94.3	93.6	66	75	83	230/460	28.61	CD0005	19	
40	29	1775	324TC*	CEM7062T	②	T3C	96/48	334	118	93.6	94.4	94.1	67	77	82	230/460	32	CD0180	19	
50	37	1775	326TC*	CEM7064T	②	T3C	114/57	392	149	94.4	94.9	94.5	73	82	87	230/460	32	CD0180	19	

* Cast Iron Frame

① Class I, Group D

② Class I, Group D, Class II, Group F & G

19 60/50 Hertz motor. 60 Hertz data shown, contact your local Baldor•Reliance office for 50 Hertz data.

35 Design A, Exceeds Design B in rush limits

CAUTION: These Explosion-proof motors are not suitable for use with adjustable speed drives. Inverter Duty Explosion-proof motors must be used, see page 27.

Baldor Explosion Proof AC and DC Motors

Motor Performance Data and Dimensions

Single Phase, C-Face, Footless

Hp	kW	RPM	NEMA Frame	Catalog Number	XP Cls & Grp	XP Temp Code	Amps @ High V		Full Load Torque Lb. Ft.	Efficiency %			Power Factor %			Voltage	"C" Dim.	Conn. Diag. Number	Notes
							Full Load	Locked Rotor		1/2	3/4	Full Load	1/2 PF	3/4 PF	Full Load PF				
0.25	0.18	1725	56C	VL5000A	②	T3C	4.2/2-2.1	10.8	0.762	50	60.6	62	47	54	64	115/208-230	13.22	CD0565	-
0.33	0.25	3450	56C	VL4005A	②	T3C	7/3.5	37	0.489	40	48.9	57	43	50	71	115/230	13.22	CD0565	-
0.33	0.25	1725	56C	VL5001A	②	T3C	6/3.2-3	13	1	41	52	60	41	52	60	115/208-230	13.22	CD0565	-
0.33	0.25	1140	56C	VL5002A	②	T4	6.8/3.4	13	1.5	41.5	50.1	54	42	50	56	115/230	14.3	CD0008	-
0.5	0.37	3450	56C	VL5003A	②	T3C	7.4/3.7	18.5	0.75	49.7	57.4	57	49	61	71	115/230	13.22	CD0565	-
0.5	0.37	1725	56C	VL5004A	②	T3C	7.4/3.9-3.7	19.41	1.5	55.2	62	64	48	59	66	115/208-230	14.22	CD0565	-
0.5	0.37	1140	56C	VL5005A	②	T4	8.0/4.0	19	2.25	57	62.3	59	41	49	63	115/230	15.17	CD0008	-
0.75	0.56	3450	56C	VL5006A	②	T4	9.8/4.9	28.3	1.13	50	58	62	60	70	75	115/230	14.3	CD0008	-
0.75	0.56	1725	56C	VL5007A	②	T4	10.6/5.3	34	2.25	58.2	65.4	66	45	56	68	115/230	15.17	CD0008	-
1	0.75	3450	56C	VL5009A	②	T4	12.0/6.0	37.9	1.51	63.2	68.3	66	66	76	81	115/230	15.17	CD0008	-
1	0.75	1725	56C	VL5023A	①	T2C	13/6.5	37	3	63	66.8	67	53	65	73	115/230	15.17	CD0008	-
1.5	1.12	3450	56C	VL5030	②	T3C	15/7.9-7.5	42	2.3	65.3	68.4	70	64	73	82	115/208-230	15.17	CD0001	-
1.5	1.12	1725	56C	VL5024A	①	T2C	16/8	47	4.5	73.9	77.8	75	59	72	78	115/230	17.42	CD0008	-
2	1.5	1725	184C	VL5027	①	T2C	22/11.6-11	61	6	72.3	74.3	75	58	69	81	115/208-230	18.43	CD0001	-

Three Phase, C-Face, Footless

Hp	kW	RPM	NEMA Frame	Catalog Number	XP Cls & Grp	XP Temp Code	Amps @ High V		Full Load Torque Lb. Ft.	Efficiency %			Power Factor %			Voltage	"C" Dim.	Conn. Diag. Number	Notes
							Full Load	Locked Rotor		1/2	3/4	Full Load	1/2 PF	3/4 PF	Full Load PF				
0.25	0.18	1725	56C	VM7001A	②	T3C	1.4-1.3/1.7	3.45	0.75	55.5	62.5	63	33	43	56	208-230/460	13.22	CD0007	-
0.33	0.25	1725	56C	VM7002A	②	T3C	1.8-1.6/1.8	4.4	1	59	65	67	40	50	57	208-230/460	13.22	CD0007	-
0.5	0.37	3450	56C	VM7005A	②	T3C	2.4-2.2/1.1	6	0.75	56.3	64	68	44	56	63	208-230/460	13.22	CD0007	-
0.5	0.37	1725	56C	VM7006A	②	T3C	2.1-2/1	6.7	1.5	65	71.7	74	39	51	63	208-230/460	13.22	CD0007	-
0.5	0.37	1140	56C	VM7007A	②	T4	2.5-2.4/1.2	5.8	2.25	57	64	70	37	47	55	208-230/460	14.3	CD0007	-
0.75	0.56	3450	56C	VM7009A	②	T3C	2.7-2.6/1.3	7.6	1.2	70.6	73.6	75	58	67	73	208-230/460	13.22	CD0007	-
0.75	0.56	1725	56C	VM7010A	②	T3C	3.2-3/1.5	10	2.25	69.7	74.7	73	42	55	58	208-230/460	14.22	CD0007	-
0.75	0.56	1140	56C	VM7031A	②	T4	3-2.8/1.4	8	3.4	71	75	77	42	55	63	208-230/460	15.17	CD0007	-
1	0.75	3450	56C	VM7013	②	T3C	3.7-3.6/1.8	19.6	1.51	76.7	79.7	75.5	65	75	71	208-230/460	13.22	CD0005	-
1	0.75	1725	56C	VM7014	②	T3C	3.8-3.6/1.8	14.6	3	70.5	76	75.5	46	57	64	208-230/460	15.22	CD0005	-
1	0.75	1750	143TC	VM7014T	②	T3C	3.2/1.6	13.2	2.99	78	81.4	82.5	50	63	73	230/460	14.33	CD0005	19
1	0.75	1155	56C	VM7032	①	T2C	3.8/1.9	10.3	4.52	73.9	77.8	78.5	41	54	63	230/460	14.3	CD0005	-
1.5	1.12	3450	143TC	VM7018T	②	T3C	4.2/2.1	16.4	2.25	80.6	82.7	82.5	75	83	88	230/460	14.33	CD0005	19
1.5	1.12	1735	56C	VM7034	②	T3C	5-4.6/2.3	17.5	4.5	77.3	80.9	81.5	51	65	74	208-230/460	14.3	CD0005	19
1.5	1.12	1755	145TC	VM7034T	②	T3C	4.8/2.4	19	4.43	79.4	83	84	48	62	70	230/460	15.21	CD0005	19
1.5	1.12	1150	145TC	VM7035T	①	T2C	5.4/2.7	20.2	6.78	82.1	84.9	85.5	41	53	61	208-230/460	17.48	CD0005	-
2	1.5	3450	145TC	VM7071T	②	T3C	5.2/2.6	22.7	2.71	77.2	80.3	84	73	80	88	230/460	15.21	CD0005	19
2	1.5	1735	56C	VM7037	②	T3C	6.0/3.0	24.8	6.05	79.2	82.2	82.5	53	67	76	230/460	15.17	CD0005	19
2	1.5	1750	145TC	VM7037T	②	T3C	6.2/3.1	23.8	5.96	81	83.6	84	50	63	72	230/460	15.21	CD0005	19
3	2.2	3450	145TC	VM7075T	①	T2C	7.9-7.4/3.7	35.5	4.67	85.6	86.6	85.5	78	86	90	208-230/460	16.1	CD0005	-
3	2.2	3460	182TC	VM7026T	②	T3C	7.8-7.4/3.7	30.5	4.7	84.9	86.2	85.5	80	88	91	208-230/460	17.49	CD0005	19
3	2.2	1750	182TC	VM7042T	②	T3C	8.2/4.1	69.2	9.01	86.4	88.1	87.5	58	70	78	230/460	18.86	CD0005	19
5	4	3465	184TC	VM7072T	②	T3C	11.2/5.6	55.2	5.45	81.6	85	87.5	81	89	93	230/460	18.06	CD0005	19, 35
5	4	1745	184TC	VM7044T	②	T3C	13.6/6.8	48.4	15	87.1	88.3	87.5	59	72	78	230/460	18.06	CD0005	19, 35
7.5	5.6	3450	184TC	VM7073T	①	T2C	17.4/8.7	98.8	11.5	88.4	89.3	88.5	83	91	93	230/460	20.36	CD0005	35
7.5	5.6	3500	213TC	VM7045T	②	T3C	17.8/8.9	73.8	11.3	87.4	89.2	88.5	81	87	89	230/460	19.19	CD0005	19, 35
7.5	5.6	1770	213TC	VM7047T	②	T3C	20.2/10.1	77.5	22.2	88.1	89.7	89.5	58	71	77	230/460	19.19	CD0005	19, 35
10	7.5	1760	215TC	VM7170T	②	T3C	26/13	85.5	26.9	87.2	88.7	89.5	61	72	80	230/460	20.65	CD0005	19

① Class I, Group D

② Class I, Group D, Class II, Group F & G

19 60/50 Hertz motor. 60 Hertz data shown, contact your local Baldor•Reliance office for 50 Hertz data.

35 Design A, Exceeds Design B in rush limits

CAUTION: These Explosion-proof motors are not suitable for use with adjustable speed drives. Inverter Duty Explosion-proof motors must be used, see page 27.

Baldor Explosion Proof AC and DC Motors

Motor Performance Data and Dimensions

Three Phase, 575 Volt, C-Face, Footless

Hp	kW	RPM	NEMA Frame	Catalog Number	XP Cls & Grp	XP Temp Code	Amps @ High V		Full Load Torque Lb. Ft.	Efficiency %			Power Factor %			Voltage	"C" Dim.	Conn. Diag. Number	Notes
							Full Load	Locked Rotor		1/2	3/4	Full Load	1/2 PF	3/4 PF	Full Load PF				
0.5	0.37	1725	56C	VM7006-5	②	T3C	0.9	5.9	1.5	59	66.7	74	41	52	60	575	14.3	CD0006	-
0.75	0.56	1725	56C	VM7010-5	②	T3C	1.2	6.7	2.3	64	70.4	76	46	58	69	575	14.3	CD0006	-
1	0.75	1740	56C	VM7014-5	②	T3C	1.5	9.57	2.99	67.4	72.9	75.5	45	57	67	575	14.3	CD0006	-
1	0.75	1760	143TC	VEM7014T-5	②	T3C	1.2	9.66	2.97	81.9	84.4	85.5	49	62	71	575	14.33	CD0006	-
1	0.75	1740	143TC	VM7014T-5	②	T3C	1.2	7.8	3	81.2	82.9	82.5	63	74	80	575	14.33	CD0006	-
1.5	1.12	1760	145TC	VEM7034T-5	②	T3C	1.8	14.6	4.47	84.5	87	86.5	51	65	73	575	15.21	CD0006	-
1.5	1.12	1755	145TC	VM7034T-5	②	T3C	1.9	15.2	4.43	79.1	83.1	84	48	61	70	575	15.21	CD0006	-
2	1.5	1755	145TC	VEM7037T-5	②	T3C	2.4	19.6	5.95	83.8	86.4	86.5	50	64	73	575	16.09	CD0006	-
2	1.5	1740	145TC	VM7037T-5	②	T3C	2.2	16.8	6	83.8	85.2	84	61	73	79	575	15.21	CD0006	-
3	2.2	1760	182TC	VEM7042T-5	②	T3C	3.3	25.9	8.88	87.7	89.5	89.5	54	67	75	575	18.86	CD0006	-
3	2.2	1750	182TC	VM7042T-5	②	T3C	3.3	25.9	8.9	86.1	87.8	87.5	59	71	78	575	18.86	CD0006	-
5	4	1750	184TC	VEM7044T-5	②	T3C	5.3	39.3	14.9	89.6	90.5	89.5	60	72	78	575	18.86	CD0006	-
5	4	1750	184TC	VM7044T-5	②	T3C	5.2	41	15	87.3	88.4	87.5	63	74	80	575	18.8	CD0006	-
7.5	5.6	1770	213TC	VM7047T-5	②	T3C	8.1	61.4	22.2	88.4	89.6	89.5	59	71	77	575	19.19	CD0006	-

② Class I, Group D, Class II, Group F & G

CAUTION: These Explosion-proof motors are not suitable for use with adjustable speed drives. Inverter Duty Explosion-proof motors must be used, see page 27.

Baldor Explosion Proof AC and DC Motors

Motor Performance Data and Dimensions

Severe Duty, Explosion-Proof Motors Rigid Base, 1.15 Service Factor

These Baldor motors are built suitable for harsh industrial environments requiring protection against corrosion, that contain hazardous gas and vapor, dust fibers, filings or other material that may have explosive properties. 1.15 Service factor, Severe Duty design includes rugged cast iron construction with corrosion resistant epoxy finish. Shaft slingers & inner caps installed on both ends of motor for bearing protection. Includes normally closed thermostats. UL & CSA approved for Division 1 Class I, Group D, Class II, Group E, F & G, T3C temperature code.



Three Phase, Foot Mounted

Hp	kW	RPM	NEMA Frame	Catalog Number	XP Cls & Grp	XP Temp Code	Amps @ High V		Full Load Torque Lb. Ft.	Efficiency %			Power Factor %			Voltage	"C" Dim.	Conn. Diag. Number	Notes
							Full Load	Locked Rotor		1/2	3/4	Full Load	1/2 PF	3/4 PF	Full Load PF				
3	2.2	1755	182T*	EM7542T-I	ⓐ	T3C	8.2/4.1	29.8	9.06	88.9	90.1	89.5	58	70	77	230/460	17.59	CD0005	-
3	2.2	1165	213T*	EM7536T-I	ⓐ	T3C	9/4.5	33.2	13.6	89	90.1	89.5	53	64	71	230/460	20.02	CD0005	-
5	4	3505	L184T*	EM7572T-I	ⓐ	T3C	12/6.0	44	7.49	89.2	89.6	88.5	74.3	83.7	87.7	230/460	17.12	416820-001	-
5	4	1750	L184T*	EM7544T-I	ⓐ	T3C	13.2/6.6	46	15	89.4	90.1	89.5	62.3	73.6	79.9	230/460	17.12	416820-001	-
5	4	1165	L215T*	EM7540T-I	ⓐ	T3C	13.6/6.8	46	22.5	89.7	90.2	89.5	59.8	71	76.9	230/460	20.12	416820-001	-
7.5	5.6	1770	213T*	EM7547T-I	ⓐ	T3C	19/9.5	68	22.1	91.6	92.3	91.7	65	76	81	230/460	20.02	CD0005	35
7.5	5.6	1180	254T*	EM7548T-I	ⓐ	T3C	21.4/10.7	69.7	32.4	89.7	91.5	91.7	52	63	71	230/460	25.81	CD0005	-
10	7.5	1765	L215T*	EM7670T-I	ⓐ	T3C	24.6/12.3	81	29.8	92.3	92.4	91.7	67.9	77.9	83	230/460	20.12	416820-002	-
10	7.5	1170	256T*	EM7565T-I	ⓐ	T3C	25/12.5	78	44.8	91.7	91.8	91	70.2	78.8	82.2	230/460	24.56	416820-002	-
15	11	1765	254T*	EM7554T-I	ⓐ	T3C	37/18.5	122.9	44.6	91.9	92.6	92.4	66	77	82	230/460	25.81	CD0005	-
20	15	3520	256T*	EM7559T-I	ⓐ	T3C	44.6/22.3	145	29.8	92.3	92.4	91.7	86.4	90.4	91.1	230/460	24.56	416820-002	-
20	15	1765	256T*	EM7556T-I	ⓐ	T3C	24	145	59.6	93.5	93.6	93	73.5	81	83.8	230/460	24.56	416820-036	-
25	18.7	1770	284T*	EM7558T-I	ⓐ	T3C	60/30.0	186	74.2	92.3	93.5	93.6	73	81	84	230/460	28.61	CD0005	-
30	22.4	1765	286T*	EM7560T-I	ⓐ	T3C	72.2/36.1	217	89.1	94.1	94.2	93.6	73.9	80.9	83.1	230/460	27.44	416820-002	-
40	29	1775	324T*	EM7562T-I	ⓐ	T3C	94/47	325	118	93.8	94.5	94.1	74	82	85	230/460	32	CD0180	-
50	37	1775	326T*	EM7564T-I	ⓐ	T3C	117/58.8	355	148	95.1	95.1	94.5	75.6	82.2	84.2	230/460	30.44	416820-002	-
50	37	1180	365T*	EM7585T-I	ⓐ	T3C	120/60.1	358	222	94.1	94.6	94.1	70.9	79.4	83	230/460	33.44	416820-002	-
60	44	1780	364T*	EM7566T-I	ⓐ	T3C	136/67.8	432	177	95.4	95.5	95	76.6	84.2	87	230/460	33.44	416820-002	-
75	56	1780	365T*	EM7568T-I	ⓐ	T3C	168/84.1	510	221	96.1	95.9	95.4	78.2	85.1	87.5	230/460	33.44	416820-002	-
75	56	1185	405T*	EM7587T-I	ⓐ	T3C	174/86.9	541	332	95	95.3	95	73	81.6	85.1	230/460	38.31	416820-002	-
100	75	1780	405T*	EM7590T-I	ⓐ	T3C	112	708	295	95.5	95.7	95.4	77.9	84.9	87.5	460	38.31	416820-036	-
100	75	1188	444T*	EM7599T-I	ⓐ	T3C	115	725	442	94.7	95.2	95	77.3	83.7	85.6	460	44.62	416820-036	-
125	93	1785	444T*	EM7600T-I	ⓐ	T3C	139	907	368	95.5	95.9	95.8	81.4	86.7	87.9	460	44.62	416820-036	-
150	112	1785	445T*	EM7596T-I	ⓐ	T3C	165	1085	441	96.4	96.6	96.2	83.1	87.7	88.5	460	44.62	416820-036	-

* Cast Iron Frame

ⓐ Class I, Group D, Class II, Group E, F & G

35 Design A, Exceeds Design B in rush limits

CAUTION: These Explosion-proof motors are not suitable for use with adjustable speed drives. Inverter Duty Explosion-proof motors must be used, see page 27.

Baldor Explosion Proof AC and DC Motors

Motor Performance Data and Dimensions

Drill Rig Duty, Explosion Proof, 1.15 Service Factor



Baldor has a family of explosion proof motors designed for on and off shore drill rig service, bulk fuel terminals, and transfer stations. For use in high humidity hazardous-duty applications driving pumps, compressors, blowers, fans, and many other loads that require 1.15 service factor explosion proof motors. Design includes Class 1, Group C & D approval for use in areas where hydrogen sulfide is present. These motors feature Labyrinth-type recessed shaft slinger for increased bearing protection. Explosion-proof breather/drain to prevent build up of condensation. Class F insulation. Corrosion resistant finish with two part epoxy coating. Suitable for 55°C at 1.0 service factor. UL and CSA approved for Division 1, Class I, Group C & D.

Three Phase, Foot Mounted

Hp	kW	RPM	NEMA Frame	Catalog Number	XP Cls & Grp	XP Temp Code	Amps @ High V		Full Load Torque Lb. Ft.	Efficiency %			Power Factor %			Voltage	"C" Dim.	Conn. Diag. Number	Notes
							Full Load	Locked Rotor		1/2	3/4	Full Load	1/2 PF	3/4 PF	Full Load PF				
1	0.75	3450	143T	EM7013T-I	(4)	T3C	2.8/1.4	10.5	1.47	71.7	76.4	77	72	82	87	230/460	14.12	CD0005	19
1	0.75	1760	143T	EM7014T-I	(4)	T3C	3/1.5	12.1	2.97	82.1	84.8	85.5	49	62	71	230/460	14.12	CD0005	19
1	0.75	1155	145T	EM7032T-I	(4)	T3C	3.6/1.8	10.8	4.51	79.4	82.3	82.5	43	55	64	230/460	15.09	CD0005	19
1.5	1.12	3500	143T	EM7018T-I	(4)	T3C	3.8/1.9	17.9	2.22	82	84.6	84	67	79	85	230/460	14.12	CD0005	19
1.5	1.12	1760	143T	EM7034T-I	(4)	T3C	4.4/2.2	18.3	4.47	84.5	86.9	86.5	51	65	73	230/460	15.09	CD0005	19
1.5	1.12	1170	182T	EM7020T-I	(4)	T3C	5.2/2.6	14.7	6.8	86	88.3	87.5	42	53	61	230/460	18.27	CD0005	19
2	1.5	3490	145T	EM7071T-I	(4)	T3C	5/2.5	25.9	2.98	83.6	85.7	85.5	75	84	88	230/460	15.09	CD0005	19
2	1.5	1755	145T	EM7037T-I	(4)	T3C	5.8/2.9	22.9	5.37	82.9	85.5	86.5	49	62	73	230/460	15.81	CD0005	19
2	1.5	1170	184T	EM7041T-I	(4)	T3C	7/3.5	20.9	9	86.7	88.6	88.5	41	52	61	230/460	19.52	CD0005	19
3	2.2	3450	182T	EM7026T-I	(4)	T3C	7.4/3.7	33.3	4.7	86.2	87.3	86.5	82	88	91	230/460	16.77	CD0005	19
3	2.2	1760	182T	EM7042T-I	(4)	T3C	8.4/4.2	30.8	7.1	86	88.5	89.5	49	62	75	230/460	18.27	CD0005	19
3	2.2	1160	213T	EM7036T-I	(4)	T3C	9.2/4.6	34.4	13.4	87.7	89.4	89.5	49	61	68	230/460	20.32	CD0005	19
5	4	3470	184T	EM7072T-I	(4)	T3C	11.2/5.6	59.3	7.66	90.7	90.8	90.2	83	90	94	230/460	18.27	CD0005	19, 35
5	4	1750	184T	EM7044T-I	(4)	T3C	13/6.5	53.7	15	89.7	90.7	89.5	62	74	80	230/460	19.52	CD0005	19
5	4	1160	215T	EM7040T-I	(4)	T3C	14.6/7.3	51.6	22.7	89.8	90.4	89.5	55	66	72	230/460	22.32	CD0005	19, 35
7.5	5.6	3470	213T	EM7045T-I	(4)	T3C	17.2/8.6	63.1	11.1	89.1	90.2	89.5	80	87	90	230/460	19.57	CD0005	19
7.5	5.6	1770	213T	EM7047T-I	(4)	T3C	18.8/9.4	69.3	17.8	90.8	91.9	91.7	56	70	81	230/460	20.32	CD0005	19, 35
7.5	5.6	1190	254T*	EM7048T-I	(4)	T3C	21.4/10.7	67	32.4	89.3	90.7	91	53	64	70	230/460	25.5	CD0005	19
10	7.5	3500	215T*	EM7174T-I	(4)	T3C	22.2/11.1	88.5	14.9	93	93.2	92.4	79	88	90	230/460	20.03	CD0005	19
10	7.5	1765	215T*	EM7170T-I	(4)	T3C	24.6/12.3	92.9	26.8	93.4	92.3	92.4	61	74	81	230/460	20.03	CD0005	19, 35
10	7.5	1180	256T*	EM7065T-I	(4)	T3C	30/15	95.3	44.4	89.8	91.4	91	52	63	70	230/460	25.5	CD0005	19
15	11	3520	254T*	EM7053T-I	(4)	T3C	35/17.5	110	22.1	91	91.6	91	77	85	87	230/460	25.5	CD0180	19
15	11	1765	254T*	EM7054T-I	(4)	T3C	36/18	125	45	92.1	93	92.4	71	81	84	230/460	25.5	CD0005	19
15	11	1180	284T*	EM7057T-I	(4)	T3C	40/20	122	65.7	90.6	92	91.7	58	69	75	230/460	28.61	CD0180	19
20	15	3530	256T*	EM7059T-I	(4)	T3C	44/22	171	29.8	92.5	93	91	87	91	91	230/460	25.5	CD0180	19, 35
20	15	1765	256T*	EM7056T-I	(4)	T3C	48/24	171	60	92.9	93.5	93	74	83	84	230/460	25.5	CD0180	19
20	15	1180	286T*	EM7079T-I	(4)	T3C	54/27	165	89.4	91.1	91.9	91.7	60	71	77	230/460	28.61	CD0180	19, 35
25	18.7	3520	284TS*	EM7063T-I	(4)	T3C	57/28.5	177	37.4	91.5	91.7	91.7	80	87	89	230/460	27.23	CD0180	19
25	18.7	1780	284T*	EM7058T-I	(4)	T3C	61/30.5	188	74	93.4	93.9	93.6	69	78	82	230/460	28.61	CD0005	19
25	18.7	1180	324T*	EM7082T-I	(4)	T3C	63/32	198	111	92.8	93.5	93	65	75	79	230/460	32	CD0180	19, 35
30	22.4	3520	286TS*	EM7083T-I	(4)	T3C	66/33	194	44.6	92.9	93.3	91.7	85	90	90	230/460	27.23	CD0180	19
30	22.4	1770	286T*	EM7060T-I	(4)	T3C	72/36	235	89.1	93.7	94.3	93.6	66	75	83	230/460	28.61	CD0005	19
30	22.4	1180	326T*	EM7080T-I	(4)	T3C	78/39	243	133	92.5	93.2	93	62	73	78	230/460	32	CD0005	19, 35
40	29	3530	324TS*	EM7067T-I	(4)	T3C	92/46	305	59.2	91.6	92.6	92.4	79	86	88	230/460	30.5	CD0180	19
40	29	1775	324T*	EM7062T-I	(4)	T3C	96/48	338	118	93.5	94.2	94.1	69	78	82	230/460	32	CD0180	19
40	29	1180	364T*	EM7084T-I	(4)	T3C	94.4/47.2	275	178	94.4	94.5	94.1	74	81.5	84.3	230/460	33.44	416820-002	19
50	37	3540	326TS*	EM7081T-I	(4)	T3C	112/56	4.8	74.4	93.8	94.2	93	82	88	90	230/460	30.5	CD0180	19, 35
50	37	1775	326T*	EM7064T-I	(4)	T3C	114/57	384	143	94.5	94.4	94.5	73	82	87	230/460	32	CD0180	19
50	37	1180	365T*	EM7085T-I	(4)	T3C	120/60.1	358	222	94.4	94.6	94.1	70.9	79.4	82.7	230/460	33.44	416820-002	19
60	44	3560	364TS*	EM7310T-I	(4)	T3C	135/67.3	415	88.5	92.7	93.7	93.6	79.6	86.4	89	230/460	31.31	416820-002	19
60	44	1780	364T*	EM7066T-I	(4)	T3C	136/67.8	432	177	95.4	95.5	95	76.6	84.2	87	230/460	33.44	416820-002	19
60	44	1185	404T*	EM7086T-I	(4)	T3C	135/67.3	434	266	94.6	94.9	94.5	79.3	86	88.3	230/460	38.31	416820-002	19
75	56	3555	365TS*	EM7313T-I	(4)	T3C	167/83.4	465	111	93	93.8	93.6	83	88.3	89.9	230/460	31.31	416820-002	19
75	56	1780	365T*	EM7068T-I	(4)	T3C	168/84.1	510	221	96.1	95.9	95.4	78.2	85.1	87.5	230/460	33.44	416820-002	19
75	56	1185	405T*	EM7087T-I	(4)	T3C	168/84.2	537	333	94.8	95	94.5	79.3	85.9	88.3	230/460	38.31	416820-002	19
100	75	1780	405T*	EM7090T-I	(4)	T3C	224/112	708	295	95.5	95.7	95.4	77.9	84.9	87.5	230/460	38.31	416820-002	19

* Cast Iron Frame

(4) Class I, Group C & D

19 60/50 Hertz motor. 60 Hertz data shown, contact your local

Baldor•Reliance office for 50 Hertz data.

35 Design A, Exceeds Design B in rush limits

CAUTION: These Explosion-proof motors are not suitable for use with adjustable speed drives. Inverter Duty Explosion-proof motors must be used, see page 27.

Baldor Explosion Proof AC and DC Motors

Motor Performance Data and Dimensions

Drill Rig Duty, Three Phase, 575 Volt, Foot Mounted

Hp	kW	RPM	NEMA Frame	Catalog Number	XP Cls & Grp	XP Temp Code	Amps @ High V		Full Load Torque Lb. Ft.	Efficiency %			Power Factor %			Voltage	"C" Dim.	Conn. Diag. Number	Notes
							Full Load	Locked Rotor		1/2	3/4	Full Load	1/2 PF	3/4 PF	Full Load PF				
3	2.2	1760	182T	EM7042T-I-5	④	T3C	3.3	25.9	8.88	87.7	89.5	89.5	54	67	75	575	18.27	CD0006	-
5	4	1750	184T	EM7044T-I-5	④	T3C	5.2	43	15	89.7	90.7	89.5	62	74	80	575	19.52	CD0006	-
7.5	5.6	1770	213T	EM7047T-I-5	④	T3C	7.6	58.5	22.2	91.9	92.3	91.7	61	74	81	575	20.32	CD0006	35
10	7.5	1765	215T*	EM7170T-I-5	④	T3C	9.8	78	29.7	93.6	92.9	92.4	62	75	80	575	20.03	CD0006	35
15	11	1765	254T*	EM7054T-I-5	④	T3C	14.8	99	44.5	91.3	92.5	92.4	67	78	82	575	25.5	CD0006	-
20	15	1765	256T*	EM7056T-I-5	④	T3C	19.2	140	59	92.8	93.1	93	69	80	84	575	25.5	CD0006	-
25	18.7	1780	284T*	EM7058T-I-5	④	T3C	24.5	158	73.9	90.6	92.5	93.6	70	79	82	575	28.61	CD0006	-
30	22.4	1770	286T*	EM7060T-I-5	④	T3C	29	177	89.2	93.9	94.4	93.6	69	77	83	575	28.61	CD0006	-
40	29	1775	324T*	EM7062T-I-5	④	T3C	39	267	118	93.6	94.3	94.1	67	77	82	575	32	CD0006	-
50	37	1775	326T*	EM7064T-I-5	④	T3C	45.6	318	149	94.4	94.9	94.5	81	80	87	575	32	CD0006	-
60	44	1780	364T*	EM7066T-I-5	④	T3C	54.2	346	177	95.4	95.5	95	76.6	84.2	87	575	33.44	416820-036	-
75	56	1780	365T*	EM7068T-I-5	④	T3C	67.2	408	221	96.1	95.9	95.4	78.2	85.1	87.5	575	33.44	416820-036	-
100	75	1780	405T*	EM7090T-I-5	④	T3C	89.6	566	295	95.5	95.7	95.4	77.9	84.9	87.5	575	38.31	416820-036	-

Drill Rig Duty, Single Phase, C-Face, Foot Mounted

Hp	kW	RPM	NEMA Frame	Catalog Number	XP Cls & Grp	XP Temp Code	Amps @ High V		Full Load Torque Lb. Ft.	Efficiency %			Power Factor %			Voltage	"C" Dim.	Conn. Diag. Number	Notes
							Full Load	Locked Rotor		1/2	3/4	Full Load	1/2 PF	3/4 PF	Full Load PF				
0.33	0.25	1725	56C	CL5001-I	④	T3C	6.6/2.9-3.3	15.5	1	39.9	48.7	55	43	52	58	115/208-230	14.31	CD0001	-
0.5	0.37	1725	56C	CL5004-I	④	T3C	8/3.8-4	24	1.5	52	60	64	45	54	63	115/208-230	14.31	CD0001	-
0.75	0.56	1725	56C	CL5007-I	④	T3C	10.6/5.3	71.5	2.24	59.8	67.1	68	47	57	70	115/208-230	15.17	CD0001	-
1	0.75	1725	56C	CL5023-I	④	T3C	12/6.0	38.6	3.11	62.3	66.5	68	66	80	77	115/230	16.05	CD0001	-

Drill Rig Duty, Three Phase, C-Face, Foot Mounted

Hp	kW	RPM	NEMA Frame	Catalog Number	XP Cls & Grp	XP Temp Code	Amps @ High V		Full Load Torque Lb. Ft.	Efficiency %			Power Factor %			Voltage	"C" Dim.	Conn. Diag. Number	Notes
							Full Load	Locked Rotor		1/2	3/4	Full Load	1/2 PF	3/4 PF	Full Load PF				
0.5	0.37	1740	56C	CM7006-I	④	T3C	1.6/8	6.34	1.49	73.8	78.4	80	45	59	63	230/460	13.14	CD0005	19
0.75	0.56	1750	56C	CM7010-I	④	T3C	2.8/1.4	9.47	1.81	65.8	71.9	78.5	40	51	66	230/460	14.28	CD0005	19
1	0.75	1750	56C	CM7014-I	④	T3C	3.2/1.6	13.2	2.99	78	81.4	82.5	50	63	73	230/460	14.28	CD0005	19
1.5	1.12	1760	145TC	CEM7034T-I	④	T3C	4.4/2.2	18.3	4.47	84.5	86.9	86.5	51	65	73	230/460	15.23	CD0005	19
2	1.5	1755	145TC	CEM7037T-I	④	T3C	5.8/2.9	22.9	5.37	82.9	85.5	86.5	49	62	73	230/460	16.1	CD0005	19
3	2.2	1760	182TC	CEM7042T-I	④	T3C	8.4/4.2	30.8	7.1	86	88.5	89.5	49	62	75	230/460	19.59	CD0005	19
5	4	1750	184TC	CEM7044T-I	④	T3C	13/6.5	53.7	15	89.7	90.7	89.5	62	74	80	230/460	20.84	CD0005	19
7.5	5.6	1770	213TC	CEM7047T-I	④	T3C	18.8/9.4	69.3	17.8	90.8	91.9	91.7	56	70	81	230/460	21.07	CD0005	19, 35
10	7.5	1765	215TC	CEM7170T-I	④	T3C	24.6/12.3	92.9	26.8	93.4	92.3	92.4	61	74	81	230/460	20.78	CD0005	19, 35
15	11	1765	254TC	CEM7054T-I	④	T3C	36/18	125	45	92.1	93	92.4	71	81	84	230/460	26	CD0005	19
20	15	1765	256TC	CEM7056T-I	④	T3C	48/24	171	60	92.9	93.5	93	74	83	84	230/460	26	CD0180	19
25	18.7	1780	284TC	CEM7058T-I	④	T3C	61/30.5	188	74	93.4	93.9	93.6	69	78	82	230/460	28.61	CD0005	19
30	22.4	1770	286TC	CEM7060T-I	④	T3C	72/36	235	89.1	93.7	94.3	93.6	66	75	83	230/460	28.61	CD0005	19
40	29	1775	324TC	CEM7062T-I	④	T3C	96/48	338	118	93.5	94.2	94.1	69	78	82	230/460	32	CD0180	19
50	37	1775	326TC	CEM7064T-I	④	T3C	114/57	384	143	94.5	94.4	94.5	73	82	87	230/460	32	CD0180	19

* Cast Iron Frame

④ Class I, Group C & D

19 60/50 Hertz motor. 60 Hertz data shown, contact your local Baldor•Reliance office for 50 Hertz data.

35 Design A, Exceeds Design B in rush limits

CAUTION: These Explosion-proof motors are not suitable for use with adjustable speed drives. Inverter Duty Explosion-proof motors must be used, see page 27.

Baldor Explosion Proof AC and DC Motors

Motor Performance Data and Dimensions

Drill Rig Duty, Three Phase, C-Face, Footless

Hp	kW	RPM	NEMA Frame	Catalog Number	XP Cls & Grp	XP Temp Code	Amps @ High V		Full Load Torque Lb. Ft.	Efficiency %			Power Factor %			Voltage	"C" Dim.	Conn. Diag. Number	Notes
							Full Load	Locked Rotor		1/2	3/4	Full Load	1/2 PF	3/4 PF	Full Load PF				
0.5	0.37	1740	56C	VM7006-I	④	T3C	1.6/8	6.34	1.49	73.8	78.4	80	45	59	69	230/460	13.14	CD0005	19
0.75	0.56	1750	56C	VM7010-I	④	T3C	2.8/1.4	10.5	2.26	71	76.2	78.5	44	56	66	230/460	14.31	CD0005	19
1	0.75	1750	56C	VM7014-I	④	T3C	3.2/1.6	13.2	2.99	78	81.4	82.5	50	63	73	230/460	14.31	CD0005	19
1	0.75	1750	143TC	VM7014T-I	④	T3C	3.2/1.6	13.2	2.99	78	81.34	82.5	50	63	73	230/460	14.36	CD0005	19
1.5	1.12	1755	56C	VM7034-I	④	T3C	4.8/2.4	19	4.43	79.4	83	84	48	62	70	230/460	15.17	CD0005	19
1.5	1.12	1755	145TC	VM7034T-I	④	T3C	4.8/2.4	19	4.43	79.4	83	84	48	62	70	230/460	15.23	CD0005	19
2	1.5	1750	145TC	VM7037T-I	④	T3C	6.2/3.1	23.8	5.96	81	83.6	84	50	63	72	230/460	15.23	CD0005	19
3	2.2	1750	182TC	VM7042T-I	④	T3C	8.2/4.1	34.6	9.01	86.4	88.1	87.5	58	70	78	230/460	19.91	CD0005	19
5	4	1750	184TC	VM7044T-I	④	T3C	13.4/6.7	49.1	10.8	85.2	87.2	87.5	54	67	80	230/460	19.91	CD0005	19
7.5	5.6	1760	213TC	VM7047T-I	④	T3C	20.4/10.2	67	18	85.4	87.7	89.5	53	66	76	230/460	21.06	CD0005	19
10	7.5	1760	215TC	VM7170T-I	④	T3C	28.4/14.2	97	26.7	86.8	89.1	89.5	52	64	73	230/460	20.77	CD0005	19

50 Hz, Explosion Proof, C-Face Motors,

Baldor motors for use on 50 hertz input power. Ideal for use on pumps, blowers and valves that require a NEMA C-face mounting configuration. Installed where hazardous fumes or dust may be present. Positively locked drive end bearing. 1.0 service factor. Available from stock in Single and Three phase, 1/3 Hp through 2 Hp, 56C through 145TC frames. UL and CSA approved for Division 1, Class I, Group D; Class I, Group D, Class II, Group F & G.



Single Phase, IP54

Hp	kW	RPM	NEMA Frame	Catalog Number	XP Cls & Grp	XP Temp Code	Amps @ High V		Full Load Torque Lb. Ft.	Efficiency %			Power Factor %			Voltage	"C" Dim.	Conn. Diag. Number	Notes
							Full Load	Locked Rotor		1/2	3/4	Full Load	1/2 PF	3/4 PF	Full Load PF				
0.33	0.25	1500	56C	CL5001A-50	②	T3C	2.6	13	1.2	50.6	58.3	59.5	46	56	68	110/220	14.22	CD0565	-
0.5	0.37	1500	56C	CL5004A-50	②	T3C	3.6	17	1.8	62.2	67.5	62	57	69	76	110/220	15.22	CD0565	-
0.75	0.56	1500	56C	CL5007A-50	②	T4	4.8	23	2.7	66.6	71.4	70	56	68	76	110/220	15.17	CD0008	-
1	0.75	1500	56C	CL5023-50	①	T3C	6.2	68	3.6	67	69	68	63	75	82	110/220	16.05	CD0001	-
2	1.5	1500	182TC	CL5027T-50	①	T2C	11.5	74	7.4	76	78	77	56	68	78	110/220	20.36	CD0001	-

Three Phase, IP54

Hp	kW	RPM	NEMA Frame	Catalog Number	XP Cls & Grp	XP Temp Code	Amps @ High V		Full Load Torque Lb. Ft.	Efficiency %			Power Factor %			Voltage	"C" Dim.	Conn. Diag. Number	Notes
							Full Load	Locked Rotor		1/2	3/4	Full Load	1/2 PF	3/4 PF	Full Load PF				
0.5	0.37	1500	56C	CM7006-57	⑧	1	6.31	1.8	66.3	71.8	73	50	62	67	230/400	14.22	CD0022	-	
0.75	0.55	1500	56C	CM7010-57	⑧	1.7	12.34	2.74	68.1	73.5	75.5	41	52	61	230/400	15.22	CD0022	-	
1	0.75	3000	56C	CM7013-57	⑧	1.7	11.8	1.8	74.8	79.3	78.5	62	73	78	230/400	14.22	CD0022	-	
1	0.75	1500	56C	CM7014-57	⑧	2	12.1	3.7	75.4	76.6	74	53	63	76	230/400	15.22	CD0022	-	
1.5	1.1	3000	143TC	CM7018T-57	⑧	2.4	18.2	2.73	78	80.7	80	70	82	88	230/400	14.36	CD0022	-	
1.5	1.1	1500	143TC	CM7034T-57	⑧	2.5	18.1	5.46	79.9	82.2	81.5	56	70	79	230/400	15.23	CD0022	-	
2	1.5	3000	145TC	CM7071T-57	⑧	3.2	22.6	3.7	76.6	80	78.5	73	83	91	230/400	15.23	CD0022	-	
2	1.5	1500	145TC	CM7037T-57	⑧	3.4	20	7.27	80.3	83	83	54	67	76	230/400	16.1	CD0022	-	

* Cast Iron Frame

① Class I, Group D

② Class I, Group D, Class II, Group F & G

④ Class I, Group C & D

19 60/50 Hertz motor. 60 Hertz data shown,

contact your local Baldor•Reliance office for 50 Hertz data.

CAUTION: These Explosion-proof motors are not suitable for use with adjustable speed drives. Inverter Duty Explosion-proof motors must be used, see page 27.

Baldor Explosion Proof AC and DC Motors

Motor Performance Data and Dimensions

Brake Motors, Explosion Proof, Three Phase, C-Face with Rigid Base



In hazardous location applications requiring quick stops and holds, Baldor offers explosion proof brake motors from stock in 3/4 hp through 3 hp, NEMA frames 56C through 215TC. These 3-phase motors are C-face mounted, and feature a spring-set brake. In the event of a power outage, a manual release allows continued operation, and then resets automatically when power is restored. Explosion-proof brakes require external connections. UL and CSA approved for Division 1, Class I, Group D; Class I, Group D, Class II, Group F & G.

All brake motors with brakes that have 20 lb-ft. static torque ratings or smaller can be mounted horizontally or vertically. For larger ratings consult a Baldor District Office.

Hp	kW	RPM	NEMA Frame	Enclosure	Catalog Number	XP Cls & Grp	XP Temp Code	Amps @ High V		Full Load Torque Lb. Ft.	Efficiency %		Power Factor %			Voltage	"C" Dim.	Conn. Diag. Number	Brake Rating	Notes	
								Full Load	Locked Rotor		1/2	3/4	Full Load	1/2 PF	3/4 PF						Full Load PF
0.5	0.37	1800	56C	XPNV	CBM7006	②	T3C	0.8	6.34	1.49	73.8	78.4	75.5	45	59	69	208-230/460	19.44	CD0005	3	-
0.75	0.56	1800	56C	XPNV	CBM7010	①	T2C	1.4	10.5	2.26	71.7	76.6	78.5	44	56	66	208-230/460	19.13	CD0005	6	2, 60
1	0.75	1800	143TC	XPNV	CBM7014T	②	T3C	1.5	12.2	2.99	81.6	84.2	80	56	70	79	208-230/460	20.37	CD0005	6	2, 60
2	1.5	1800	182TC	XPNV	CBM7023T	①	T2C	2.9	26	6	80.8	83.7	84	57	69	76	230/460	23.24	CD0005	10	2, 60
3	2.2	1800	182TC	XPFC	CEBM7142T	②	T3C	4.1	32	8.9	87	89.1	89.5	53.7	65.7	73	230/460	27.22	416820-1	15	-
3	2.2	1800	215TC	XPNV	CBM7027T	①	T2C	4.3	33	9	81.3	84.2	84	56	69	77	230/460	27.31	CD0005	15	2, 40, 60
5	4	1800	184TC	XPFC	CEBM7144T	②	T3C	6.5	46	14.9	88	89.5	89.5	54.5	66.5	73.7	230/460	27.22	416820-1	25	-

Jet Pump Explosion-Proof Motors



In applications where a threaded shaft jet pump motor is used in hazardous locations, Baldor offers explosion-proof motors available from stock in single and three phase, 1/2 hp through 2 hp, in NEMA frame 56J. They are UL and CSA approved for Class I – Group D and Class II – Group F and G.

Performance Data, Single Phase

Hp	kW	RPM	NEMA Frame	Catalog Number	XP Cls & Grp	XP Temp Code	Amps @ High V		Full Load Torque Lb. Ft.	Efficiency %		Power Factor %			Voltage	"C" Dim.	Conn. Diag. No.	Notes	
							Full Load	Locked Rotor		1/2	3/4	Full Load	1/2	3/4					Full Load
0.50	0.37	3450	56J	JL5003A	②	T4	3.9	23.0	0.75	41.2	49.7	55.0	51	59	69	115/230	14.79	CD0008	-
0.75	0.56	3450	56J	JL5006A	②	T4	4.9	28.3	1.2	50.0	58.0	62.0	60	70	75	115/230	14.79	CD0008	-
1	0.75	3450	56J	JL5009A	②	T4	6.0	35.0	1.5	65.0	67.0	66.0	64	75	81	115/230	15.68	CD0008	30
1.5	1.12	3450	56J	JL5030	②	T4	7.5	42.0	2.3	65.3	68.4	70.0	64	73	82	115/208-230	15.68	CD0001	-
2	1.5	3450	56J	JL5031	②	T4	11.5	78.0	3.0	64.2	70.5	74.0	65	75	82	115/208-230	16.56	CD0001	-

Performance Data, Three Phase

Hp	kW	RPM	NEMA Frame	Catalog Number	XP Cls & Grp	XP Temp Code	Amps @ High V		Full Load Torque Lb. Ft.	Efficiency %		Power Factor %			Voltage	"C" Dim.	Conn. Diag. No.	Notes	
							Full Load	Locked Rotor		1/2	3/4	Full Load	1/2	3/4					Full Load
1	0.75	3450	56J	JM7013	②	T4	1.8	11.0	1.5	72.1	76.8	75.5	53	68	71	230/460	13.72	CD0005	-
1.5	1.12	3450	56J	JM7018	②	T4	2.3	16.0	2.3	66.7	72.7	75.5	59	71	76	208-230/460	14.79	CD0005	-
2	1.5	3450	56J	JM7071	②	T4	2.7	17.5	3.0	78.2	80.3	78.5	80	87	93	208-230/460	15.67	CD0005	-

* Cast Iron Frame

① Class I, Group D

② Class I, Group D, Class II, Group F & G

④ Class I, Group C & D

2 1.00 Service Factor

40 Brake motors may be mounted vertically with brake below motor.

60 Totally Enclosed Non-Ventilated, Continuous Duty.

CAUTION: These Explosion-proof motors are not suitable for use with adjustable speed drives. Inverter Duty Explosion-proof motors must be used, see page 27.

Baldor Explosion Proof AC and DC Motors

Motor Performance Data and Dimensions

Close-Coupled Pump, Explosion-Proof Motors

Where close-coupled pump shaft configurations are required in hazardous locations, Baldor offers explosion-proof motors available from stock in three phase, 3 hp through 10 hp, in NEMA frames 145JM through 215JM. They are UL and CSA approved for Division 1, Class I, Group D, Class II, Group F & G, and are rated at a 1.0 Service Factor.



Three Phase

Hp	kW	RPM	Frame	Catalog Number	XP Cls & Grp	XP Temp Code	Amps @ High V		Full Load Torque Lb. Ft.	Efficiency %			Power Factor %			Voltage	"C" Dim.	Conn. Diag. No.
							Full Load	Locked Rotor		1/2	3/4	Full Load	1/2	3/4	Full Load			
3	2.2	3450	145JM	JMM7075T	①	T2C	3.8	32.9	4.6	83.0	84.3	82.5	74	83	89.0	208-230/460	17.80	CD0005
3	2.2	3450	182JM	JMM7026T	①	T2C	3.9	35.0	4.5	78.1	81.5	81.5	77	85	89.0	208-230/460	19.00	CD0005
5	4	3450	184JM	JMM7072T	①	T2C	6.0	47.0	7.5	85.8	86.5	85.5	88	93	93.0	230/460	20.38	CD0005
7.5	5.6	3450	184JM	JMM7073T	①	T2C	8.6	76.0	11.3	87.8	88.1	87.5	84	90	94.0	230/460	21.88	CD0005
7.5	5.6	3450	213JM	JMM7045T	①	T2C	9.3	88.7	11.4	82.6	85.4	84.0	84	89	88.0	230/460	20.05	CD0005
10	7.5	3450	215JM	JMM7074T	①	T2C	12.0	100	15.0	83.4	85.9	86.5	85	91	91.0	230/460	21.19	CD0005

① Class I, Group D

Close-Coupled Pump, Drill Rig Duty, Explosion-Proof Motors

Baldor motors designed for on and off shore drill rig service, bulk fuel terminals, and transfer stations where close-coupled pump shaft configurations are required. For use in high humidity hazardous-duty applications driving pumps, compressors, blowers and fans. These motors feature Labyrinth-type recessed shaft slinger for increased bearing protection. Explosion-proof breather/drain to prevent build up of condensation. Class F insulation. Corrosion resistant finish with two part epoxy coating. Rated for 55° C ambient and 1.15 service factor (EJPM71170T-I has 1.0 S.F.). UL and CSA approved for Division 1, Class I, Group C & D. Available from stock 3 hp to 10 hp with 182JP to 184JP mounting.



Three Phase, JP Mount with Rigid Base

Hp	kW	Actual RPM	NEMA Frame	Catalog Number	XP Cls & Grp	XP Temp Code	Amps @ High V		Full Load Torque Lb.Ft.	Efficiency %			Power Factor %			Voltage	"C" Dim.	Conn. Diag. #	Notes
							Full Load	Locked Rotor		1/2	3/4	Full Load	1/2 pf	3/4 pf	Full Load pf				
3	2.2	1755	182JP	EJPM7142T-I	④	T3C	4.1	28.7	7.24	86.9	88.7	89.5	52	65	77	230/460	22.09	CD0005	1, 19, 30
5	4	1750	184JP	EJPM7144T-I	④	T3C	6	43.9	10.8	87.7	88.7	89.5	52	65	79	230/460	22.09	CD0005	1, 19, 30
7.5	5.6	1770	213TCZ	EJPM71147T-I	④	T3C	9.5	65.8	17.8	90.1	91.3	91.7	58	71	81	230/460	25.65	CD0005	1, 19, 97
10	7.5	1765	215TCZ	EJPM71170T-I	④	T3C	12.3	95.7	29.7	93.6	92.6	92.4	64	76	81	230/460	25.65	CD0005	19, 97

① Class I, Group D

④ Class I, Group C & D

1 Class F insulated motor with 1.15 Service Factor or higher that operates within Class "B" temperature limits at rated horsepower

19 60/50 Hertz motor. 60 Hertz data shown, contact your local Baldor•Reliance office for 50 Hertz data

30 Usable at 208 volts

97 One size smaller flange and shaft

CAUTION: These Explosion-proof motors are not suitable for use with adjustable speed drives. Inverter Duty Explosion-proof motors must be used, see page 27.

Baldor Explosion Proof AC and DC Motors

Motor Performance Data and Dimensions

Submersible Explosion-Proof Motors

Baldor Submersible motors are designed for wet pit applications that require Continuous Duty in water/ sewage and 15 Minute Duty in air. Single phase designs are suitable for use on Sine wave power only. Three Phase designs are suitable for 10:1 Variable torque for Division 1, Class I, Group D, T2A temperature code.



Single Phase

Hp	kW	RPM	NEMA Frame	Catalog Number	XP Cls & Grp	XP Temp Code	Amps @ High V		Full Load Torque Lb. Ft.	Efficiency %			Power Factor %			Motor Voltage	Connected Voltage	Dim Sheet	Conn. Diag. Number	Notes
							Full Load	Locked Rotor		1/2	3/4	Full Load	1/2 PF	3/4 PF	Full Load PF					
1	0.75	1730	180TY	C18G2730	④	T3C	8.1	40	3.04	42.7	50.6	55	60.8	67.9	72.9	115/230	230	66930-20	416820-102	97
1	0.75	1150	180TY	C18G2700	④	T3C	8.6	36.5	4.57	45.4	52.1	55.6	55.2	62.2	68.1	115/230	230	66930-20	416820-102	97
1.5	1.12	1735	180TY	C18G2731	④	T3C	10.6	100	4.54	51.3	58.7	62.5	60.2	68.2	73.6	115/230	230	66930-20	416820-102	97
1.5	1.12	1150	180TY	C18G2701	④	T3C	12.5	51.2	6.82	48.1	54.9	57	54.9	62.2	68.1	115/230	230	66930-20	416820-102	97
2	1.5	1720	180TY	C18G2702	④	T3C	14	69	6.11	50	57.2	60.9	65.6	71.1	73.9	115/230	230	66930-20	416820-102	97
3	2.2	1725	180TY	C18G2703	④	T3C	20	97	9.13	58.6	63.6	64.7	59.5	69.1	75.4	115/230	230	66930-17	416820-102	-
3	2.2	1725	180TY	C18G2704	④	T3C	20	97	9.13	58.6	63.6	64.7	59.5	69.1	75.4	115/230	230	66930-20	416820-102	97
3	2.2	1160	210TY	C21G2701	④	T3C	21	86	13.6	56.7	62.9	65.6	54.1	63.7	69.1	115/230	230	66930-20	416820-102	97
5	4	1730	210TY	C21G2702	④	T3C	30	146	15.2	63.9	67.5	69	66.9	76.1	80.4	230	230	66930-18	416820-101	-

Submersible Explosion-Proof, Three Phase Motors

Hp	kW	RPM	NEMA Frame	Catalog Number	XP Cls & Grp	XP Temp Code	Amps @ High V		Full Load Torque Lb. Ft.	Efficiency %			Power Factor %			Motor Voltage	Connected Voltage	Dim Sheet	Conn. Diag. Number	Notes
							Full Load	Locked Rotor		1/2	3/4	Full Load	1/2 PF	3/4 PF	Full Load PF					
1	0.75	1745	180TY	P18G2784	④	T3C	1.7	13.7	3.01	50	58.5	63.5	77.5	83	86.4	230 / 460	230	66930-20	416820-1	97
1.5	1.12	1735	180TY	P18G2787	④	T3C	2.3	18.3	4.45	59.3	66.7	70.5	77.5	83.1	86.2	230 / 460	230	66930-20	416820-1	97
2	1.5	1730	180TY	P18G2791	④	T3C	2.9	22	6.06	64.3	70.7	73.5	74.7	82.5	86.4	230 / 460	230	66930-20	416820-1	97
2	1.5	1730	180TY	P18G2792	④	T3C	3.3	25.3	6.06	64.3	70.7	73.5	74.7	82.5	86.4	200 / 400	200	66930-20	416820-1	97
3	2.2	1750	180TY	P18G2794	④	T3C	4.4	31.1	9.01	70.5	75.9	78.1	68.7	77.2	81.7	230 / 460	230	66930-20	416820-1	97
3	2.2	1160	180TY	P18G2707	④	T3C	5.2	26	13.6	72	76.6	78	54.4	63.8	69.3	230 / 460	230	66930-17	416820-1	-
5	4	1725	180TY	P18G2701	④	T3C	7	40	15.2	77	79.9	80.2	71.9	79.9	83.9	230 / 460	230	66930-17	416820-1	-
5	4	1725	180TY	P18G2702	④	T3C	7	40	15.2	77	79.9	80.2	71.9	79.9	83.9	230 / 460	460	66930-17	416820-1	-
5	4	1725	180TY	P18G2739	④	T3C	8.05	46	15.2	77	79.9	80.2	71.9	79.9	83.9	200 / 400	200	66930-17	416820-1	-
5	4	1150	180TY	P18G2709	④	T3C	8	38	22.8	77.9	80.7	80.9	55.4	66	72	230 / 460	230	66930-17	416820-1	-
5	4	870	210TY	P21G2747	④	T3C	8.3	40.5	30.2	79.1	82.1	82.6	48.2	59.9	67.9	460	460	66930-18	416820-24	-
7.5	5.6	1730	180TY	P18G2703	④	T3C	10.1	62.5	22.7	80.7	82.9	82.7	72.1	80.1	83.9	230 / 460	230	66930-17	416820-1	-
7.5	5.6	1730	180TY	P18G2704	④	T3C	10.1	62.5	22.7	80.7	82.9	82.7	72.1	80.1	83.9	230 / 460	460	66930-17	416820-1	-
7.5	5.6	1150	210TY	P21G2705	④	T3C	11.3	59	34.2	79.2	81.7	81.7	59.6	70.2	75.7	230 / 460	230	66930-18	416820-1	-
10	7.5	1755	210TY	P21G2701	④	T3C	13	76	29.9	83	85.3	85.6	72.8	80.6	84.1	230 / 460	230	66930-18	416820-1	-
10	7.5	1755	210TY	P21G2702	④	T3C	13	76	29.9	83	85.3	85.6	72.8	80.6	84.1	230 / 460	460	66930-18	416820-1	-
10	7.5	1145	210TY	P21G2707	④	T3C	14.4	79	45.8	83.8	84.8	83.8	63	73.1	77.7	230 / 460	230	66930-18	416820-1	-
15	11	1745	210TY	P21G2703	④	T3C	20.1	114	45.1	83.3	85.4	85.4	69.2	77.9	82	230 / 460	230	66930-18	416820-2	-
15	11	1745	210TY	P21G2704	④	T3C	20.1	114	45.1	83.3	85.4	85.4	69.2	77.9	82	230 / 460	460	66930-18	416820-2	-
15	11	1160	250TY	P25G2707	④	T3C	20.3	110	67.8	86	87.2	86.5	68	76.7	80	230 / 460	460	66930-18	416820-1	-
20	15	1740	210TY	P21G2737	④	T3C	26.2	141	60.4	86.1	87.2	86.6	69.7	78.6	82.7	230 / 460	460	66930-20	416820-2	97
20	15	1740	210TY	P21G2758	④	T3C	26.2	141	60.4	86.1	87.2	86.6	69.7	78.6	82.7	230 / 460	460	66930-18	416820-2	-
20	15	1160	250TY	P25G2710	④	T3C	27.4	144	90.5	86.7	87.6	86.7	66.6	75.4	78.8	230 / 460	460	66930-18	416820-2	-
25	18.7	1760	250TY	P25G2702	④	T3C	32.1	175	74.6	87.2	88.7	88.5	71.3	79.3	82.5	230 / 460	460	66930-18	416820-1	-
25	18.7	1760	250TY	P25G2747	④	T3C	32.1	175	74.6	87.2	88.7	88.5	71.3	79.3	82.5	230 / 460	460	66930-28	416820-1	97
25	18.7	1160	250TY	P25G2712	④	T3C	35.2	182	113	86.3	87.4	86.7	59.9	71	76.6	230 / 460	460	66930-18	416820-2	-
30	22.4	1750	250TY	P25G2704	④	T3C	39.9	208	89.9	87.5	88.9	88.7	64.5	74.5	79.4	230 / 460	460	66930-18	416820-1	-
30	22.4	1175	320TY	P32G2700	④	T3C	40.7	213	134	88.2	89.7	89.7	60.7	71.3	76.8	460	460	66930-18	416820-25	-
40	29	1740	250TY	P25G2706	④	T3C	51.7	257	121	89.2	89.8	89	70.4	78.5	81.4	460	460	66930-18	416820-25	-
50	37	1770	320TY	P32G2701	④	T3C	64.3	362	148	89.3	90.9	91.1	67.9	76.2	79.8	460	460	66930-18	416820-25	-
50	37	1770	320TY	P32G2724	④	T3C	64.3	362	148	89.3	90.9	91.1	67.9	76.2	79.8	460	460	66930-28	416820-25	-
50	37	1175	320TY	P32G2702	④	T3C	65.9	348	224	90.1	90.9	90.5	62.5	73.2	78.5	460	460	66930-18	416820-25	-
60	44	1770	320TY	P32G2706	④	T3C	74.9	415	178	91.3	92.2	92	69.1	77.8	81.4	460	460	66930-18	416820-25	-
75	56	1765	320TY	P32G2703	④	T3C	91.3	514	223	92.3	92.9	92.6	72.8	80.2	83	460	460	66930-18	416820-25	-
75	56	1170	360TY	P36G2700	④	T3C	90.9	508	338	93.6	93.3	92.3	73.7	81.2	83.8	460	460	66930-60	416820-25	-
100	75	1770	360TY	P36G2701	④	T3C	116	703	296	90.4	91.6	91.6	76	83.4	86.2	460	460	66930-60	416820-25	-
100	75	1165	360TY	P36G2702	④	T3C	122	703	451	91.7	92	91.2	76	82.4	84.2	460	460	66930-60	416820-25	-

④ Class I, Group C & D

97 One size smaller flange and shaft

Baldor Explosion Proof AC and DC Motors

Motor Performance Data and Dimensions

Adjustable Speed AC Three Phase, Inverter Drive® Explosion-Proof Motors

These TEFC motors are designed for use with inverters in hazardous locations. Ratings are available for a 10:1 constant or variable torque speed rating. They may be used with a Baldor inverter or one manufactured by another company. The 1/2 hp through 2 hp motors meet Division 1, Class I – Group D and Class II – Group F and G, with Temperature rating T3C (160 degrees). The 3 hp through 75 hp motors meet Division 1, Class I – Group D only, with Temperature Code T2A (280 degrees). NEMA frames 56C through 405T. ISR® Inverter Spike Resistant wire is standard. All motors are rated at a 1.0 Service Factor, and have Class F insulation to meet NEMA MG 1-2011, Part 31. All ratings constant horsepower 60 to 90 Hz.



Mechanical Design Characteristics

Specification	Description	Frames			
		56C	143TC-215TC	254TC-365TC	405T
Bearing Retention	Locked bearings for universal mounting	•	•	•	•
Bearings	Premium grade, double shielded	•	•		
	Premium grade, open with Lube Lock®			•	•
Conduit Box & Lid	U. L. approved cast iron explosion-proof	•	•	•	•
Drive End	C-Face for mounting flexibility on NEMA TC frames	•	•		•
Endplates	Aluminum with steel bearing journal	•	thru145TC		
	Cast iron - rugged and durable		from 182TC	•	•
Explosion-Proof Classifications	Class I, Group D, Class II, Group F & G. Temp. Rating 160°C	•	thru 145TC		
	Class I, Group D only. Temperature Rating 280°C		from 182TC	•	•
Frame	Steel band	•	thru 145TC		
	Cast iron		from 182TC	•	•
Foot Mounting	Rigid base, dual hole foot pattern for mounting flexibility	•	•	•	•
Ground Screw	Inside terminal box for convenience	•	•	•	•
Lifting Provisions	Eyebolt		•	•	•
Lubricant	Exxon POLYREX®EM or equivalent	•	•	•	•
Nameplate	UL/CSA listed nameplate. Includes base volts and frequency, connection diagram	•	•	•	•
Rotor Construction	Special high pressure aluminum die cast with low loss electrical steel and special slot configuration	•	•	•	•
Shaft Material	C1035 steel	•	•		
	C1137 steel			•	•

Electrical Design Characteristics

Specification	Description	Frames			
		56C	143TC-215TC	254TC-365TC	405T
Insulation	Class F Meets NEMA MG 1-2011, Part 31	•	•	•	•
Magnet Wire	200°C moisture resistant,	•	•	•	•
Service Factor	1.00	•	•	•	•
Voltage	230 / 460V @ 60 Hertz	•	•	•	•

Baldor Explosion Proof AC and DC Motors

Motor Performance Data and Dimensions

AC Inverter Drive® Explosion-Proof Fan-Cooled Motors

UL and CSA approved for use in hazardous locations. 1/2 through 2 hp Class I, Group D, Class II, Group F & G. Temperature rating T3C (160°C). 3 hp and larger Division 1, Class I, Group D only. Temperature Code T2B (260°C). 1.0 service factor. Class F insulation. All ratings constant horsepower 60 to 90 Hz.

Performance Data 230/460 Volt Ratings

10:1 Variable Torque and 2:1 Constant Torque Ratings

Hp	kW	Base Spd	Max. RPM	Max. Frame	NEMA Encl.	Catalog No.	XP Cls & Grp	XP Temp Code	460 Volt Line Amps		Output Torque Lb-Ft.			% Effic. Line	Wk ² Lb-Ft ²	Ap'x Wgt. Lbs.	"C" Dim.	Conn. Diag. No.
									Idle	F.L.	F.L.	L.R.	B.D.					
3	2.2	1760	2700	182TC*	TEFC	IDXM7142T	①	T2B	2.2	4.0	9.0	22.0	31.0	89.5	0.26	147	18.24	CD0005
5	4	1760	2700	184TC*	TEFC	IDXM7144T	①	T2B	3.4	6.5	15.0	32.0	50.0	89.5	0.4	161	18.24	CD0005
7.5	5.6	1760	2700	213TC*	TEFC	IDXM7147T	①	T2B	4.9	9.7	22.4	42.9	69.9	90.2	0.85	228	20.69	CD0005
10	7.5	1760	2700	215TC*	TEFC	IDXM7170T	①	T2B	5.5	12.5	30.0	56.0	121	91.7	1.14	196	20.69	CD0005
15	11	1765	2700	254TC*	TEFC	IDXM7054T	①	T2B	6.95	18.0	45.0	88.0	143	92.4	1.84	356	26.00	CD0005
20	15	1765	2700	256TC*	TEFC	IDXM7056T	①	T2B	8.5	24.0	60.0	120	183	93.0	2.27	393	26.00	CD0180
25	18.7	1780	2700	284T*	TEFC	IDXM7058T	①	T2B	11.9	30.5	74.0	137	226	93.6	3.98	494	28.61	CD0005
30	22.4	1780	2700	286T*	TEFC	IDXM7060T	①	T2B	14.5	36.0	90.0	143	256	94.1	4.46	555	28.61	CD0005
40	29	1780	2700	324T*	TEFC	IDXM7062T	①	T2B	16.01	47.0	118	207	385	94.1	7.5	782	32.12	CD0180
50	37	1780	2700	326T*	TEFC	IDXM7064T	①	T2B	19.13	57.0	148	290	451	94.5	9.64	772	32.12	CD0180
60	44	1780	2700	364T*	TEFC	IDXM7066T	①	T2B	23.5	69.0	177	278	556	95.0	11.7	1006	33.25	CD0180
75	56	1780	2700	405T*	TEFC	IDXM7068T	①	T2B	23.6	85.0	225	388	515	94.1	22.4	1369	38.75	CD0005

10:1 Variable Torque and Constant Torque Ratings

Hp	kW	Base Spd	Max. RPM	Max. Frame	NEMA Encl.	Catalog No.	XP Cls & Grp	XP Temp Code	460 Volt Line Amps		Output Torque Lb-Ft.			% Effic. Line	Wk ² Lb-Ft ²	Ap'x Wgt. Lbs.	"C" Dim.	Conn. Diag. No.
									Idle	F.L.	F.L.	L.R.	B.D.					
0.50	0.37	1750	2700	56C	TEFC	IDXM7006	②	T3C	0.5	0.8	1.5	5.6	6.7	82.5	0.09	42	14.30	CD0005
0.75	0.56	1750	2700	56C	TEFC	IDXM7010	②	T3C	0.61	1.1	2.25	8.4	8.8	82.5	0.12	46	14.30	CD0005
1	0.75	1750	2700	143TC	TEFC	IDXM7014T	②	T3C	0.81	1.4	3.0	10.0	14.5	85.5	0.142	50	15.23	CD0005
1.5	1.12	1750	2700	145TC	TEFC	IDXM7034T	②	T3C	1.13	2.1	4.5	19.0	23	88.5	0.166	53	15.23	CD0005
2	1.5	1750	2700	145TC	TEFC	IDXM7037T	②	T3C	1.3	2.6	6.0	25.3	27.4	88.5	0.237	70	17.48	CD0005
3	2.2	1760	2700	182TC*	TEFC	IDXM7542T	②	T3C	2.2	4.0	9.0	22.0	31.0	89.5	0.26	144	18.24	CD0005
5	4	1760	2700	213TC*	TEFC	IDXM7544T	①	T2B	2.6	6.3	15.0	29.4	41.2	90.2	0.608	212	20.65	CD0005
7.5	5.6	1760	2700	215TC*	TEFC	IDXM7547T	①	T2B	4.9	9.7	22.4	42.9	69.9	90.2	0.84	225	20.65	CD0005
10	7.5	1760	2700	254TC*	TEFC	IDXM7570T	①	T2B	5.4	12.8	29.7	75.0	110	92.4	2.09	378	26.00	CD0005
15	11	1765	2700	256TC*	TEFC	IDXM7554T	①	T2B	7.0	17.0	45.0	93.0	151	92.4	2.1	381	26.00	CD0005
20	15	1765	2700	284T*	TEFC	IDXM7556T	①	T2B	8.6	24.5	59.0	96.0	167	90.2	3.5	516	28.61	CD0005
25	18.7	1780	2700	324T*	TEFC	IDXM7558T	①	T2B	10.6	30.0	74.0	114	226	91.7	6.16	705	32.12	CD0180
30	22.4	1780	2700	326T*	TEFC	IDXM7560T	①	T2B	13.3	35.0	89.0	147	276	94.5	7.5	731	32.12	CD0180
40	29	1780	2700	364T*	TEFC	IDXM7562T	①	T2B	12.2	48.0	118	218	297	92.4	11.7	913	33.25	CD0005
50	37	1780	2700	365T*	TEFC	IDXM7564T	①	T2B	12.2	57.0	147	266	343	92.4	11.7	971	33.25	CD0180
60	44	1780	2700	405T*	TEFC	IDXM7566T	①	T2B	17.8	69.0	177	332	425	93.6	22.4	1341	38.75	CD0005

* Cast Iron Frame

① Class I, Group D

② Class I, Group D, Class II, Group F & G

Baldor Explosion Proof AC and DC Motors

Motor Performance Data and Dimensions

Explosion-Proof Inverter Drive® Motor Capabilities

Hp	kW	2:1 CTSR 10:1 VTSR Frame	10:1 CTSR 10:1 VTSR Frame	Base Speed	Maximum Speed	Hp	kW	2:1 CTSR 10:1 VTSR Frame	10:1 CTSR 10:1 VTSR Frame	Base Speed	Maximum Speed	
0.5	0.37	56*	56	3600	3600	30	22.4	286T	326T	3600	3600	
			56	1800	2700			286T*	326T	1800	2700	
			56	1200	1800			326T	364T	1200	1800	
0.75	0.56	56*	56	3600	3600	40	29	324T	364T	3600	3600	
			56	1800	2700			324T*	364T	1800	2700	
			143T	1200	1800			364T	404T	1200	1800	
1	0.75	143T*	56	3600	3600	50	37	326T	365T	3600	3600	
			143T	1800	2700			326T*	365T	1800	2700	
			145T	1200	1800			404T	405T	1200	1800	
1.5	1.12	145T*	143T	3600	3600	60	44	365T	405T	3600	3600	
			145T	1800	2700			364T*	405T	1800	2700	
			182T	1200	1800			404T	444T	1200	1800	
2	1.5	145T*	145T	3600	3600	75	56	365T	444T	3600	3600	
			145T	1800	2700			405T*	444T	1800	2700	
			213T	1200	1800			444T	445T	1200	1800	
3	2.2	182T	182T	3600	3600	100	75	444T	445T	3600	3600	
			182T*	1800	2700			444T	445T	1800	2700	
			213T	1200	1800			445T	447T	1200	1800	
5	4	184T*	184T	3600	3600	125	93	445T	447T	3600	3600	
			184T*	1800	2700			445T	449T	1800	2700	
			215T	1200	1800			447T	449T	1200	1800	
7.5	5.6	213T	213T	3600	3600	150	112	447T	449T	3600	3600	
			213T*	1800	2700			447T	449T	1800	2700	
			254T	1200	1800			449T	449T	1200	1800	
10	7.5	215T	254T	3600	3600	200	149	449T	449T	3600	3600	
			215T*	1800	2700			449T	449T	1800	2700	
			256T	1200	1800			449T	449T	1200	1800	
15	11	254T*	254T	3600	3600	250	187	449T	449T	3600	3600	
			254T*	1800	2700			449T	449T	1800	2700	
			284T	1200	1800			449T	N/A	1200	1800	
20	15	256T	284T	3600	3600	300	224	449T	N/A	3600	3600	
			256T*	1800	2700			449T	N/A	1800	2700	
			286T	1200	1800			N/A	N/A	1200	1800	
25	18.7	284T*	284T	3600	3600							
			284T*	1800	2700							
			324T	1200	1800							

Note: * Areas are available from stock.

Matched Performance™: The Perfect Motor and Control for Your Application

Many motor and drive manufacturers claim that their products are designed to work together, but only Baldor backs up the claim with specific data. Introduced in 1993, Matched Performance provides lab-tested performance curve data on Baldor motors and controls, 1 to 800 hp, including inverters, vectors and servos. Showing peak torque, continuous torque, maximum speed and current, each Matched Performance curve illustrates the continuous and intermittent torque available from the motor at various speeds. This lets you know the motor's safe operating envelope below and above its base speed.

*** NOTE:** Baldor Inverters are supplied with NEMA 1 enclosures which are not approved for hazardous locations and should be remotely mounted. If the inverter drive needs to be mounted near the motor, contact your local Baldor district office.

Matched Performance Curve for 15 Hp Inverter Drive® Explosion-Proof Motor and Control*

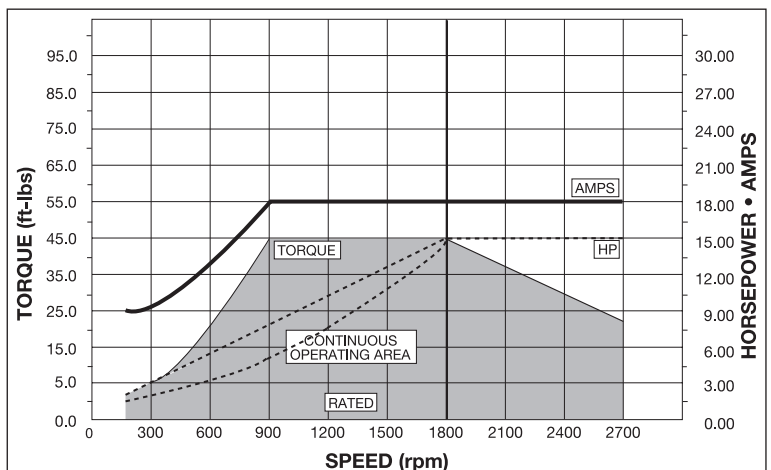

Motor: IDXM7054T - 15 Hp
Control: ID15H415-E - 15 Hp Series 15H Inverter

Baldor Explosion Proof AC and DC Motors

Motor Performance Data and Dimensions

Explosion-Proof SCR Drive Permanent Magnet and Shunt Wound DC Motors



When it comes to explosion-proof SCR Drive DC motors, Baldor offers two choices. Permanent Magnet motors are available from stock in 1/4 hp through 1-1/2 hp, in NEMA frames 56C and 145TC. Shunt Wound motors are available from stock in 1/2 hp through 3 hp, in NEMA frames 182CZ to 215CY. Both types are UL and CSA approved for Division 1, Class I – Group D and Class II – Groups F and G, with a 1.0 Service Factor. Most models include a thermostat on the field winding.

SCR Drive Permanent Magnet DC Motors

Hp	kW	Base Speed	NEMA Frame	Catalog No.	XP Cls & Grp	XP Temp Code	Voltage Direct Current		Full Load Amperage		Ap'x. Shpg. Wgt.	Conn. Diag. No.
							Arm.	Fld.	Arm.	Fld.		
0.25	0.18	1750	56C	CDPX3410	②	T3C	90	PM	2.7	PM	38	CD0194
0.25	0.18	1750	56C	CDPX3406	②	T3C	180	PM	1.3	PM	38	CD0194
0.33	0.25	1750	56C	CDPX3420	②	T3C	90	PM	3.6	PM	42	CD0194
0.33	0.25	1750	56C	CDPX3416	②	T3C	180	PM	1.7	PM	44	CD0194
0.50	0.37	1750	56C	CDPX3430	②	T3C	90	PM	5.2	PM	46	CD0194
0.50	0.37	1750	56C	CDPX3426	②	T3C	180	PM	2.5	PM	46	CD0194
0.75	0.56	1750	56C	CDPX3440	②	T3C	90	PM	7.0	PM	51	CD0194
0.75	0.56	1750	56C	CDPX3436	②	T3C	180	PM	3.5	PM	51	CD0194
1	0.75	1750	56C	CDPX3545	②	T3C	90	PM	9.6	PM	72	CD0194
1	0.75	1750	56C	CDPX3555	②	T3C	180	PM	4.9	PM	71	CD0194
1.5	1.12	1750	145TC	CDPX3575	②	T3C	180	PM	7.1	PM	81	CD0194

SCR Drive Shunt Wound DC Motors

Hp	kW	Base Speed	NEMA Frame	Catalog No.	XP Cls & Grp	XP Temp Code	Voltage Direct Current		Full Load Amperage		Ap'x. Shpg. Wgt.	Conn. Diag. No.
							Arm.	Fld.	Arm.	Fld.		
0.50	0.37	1750	182CZ	CDX1850	②	T3B	90	100/50	4.9	0.55	103	CD0860
0.75	0.56	1750	182CZ	CDX1875	②	T3B	90	100/50	7.0	0.55	100	CD0860
1	0.75	1750	182CZ	CDX2001	②	T3B	180	200/100	5.0	0.25	105	CD0860
1	0.75	1750	182C	CDX7100	②	T3B	180	200/100	5.0	0.25	103	CD0860
1.5	1.12	1750	184C	CDX7150	②	T3B	180	200/100	7.5	0.25	121	CD0860
2	1.5	1750	184C	CDX7200	②	T3B	180	200/100	9.5	0.40	135	CD0860

② Class I, Group D, Class II, Group F & G

Baldor Explosion Proof AC and DC Motors

Motor Dimensions

Horizontal Base Mount Explosion-Proof Motors

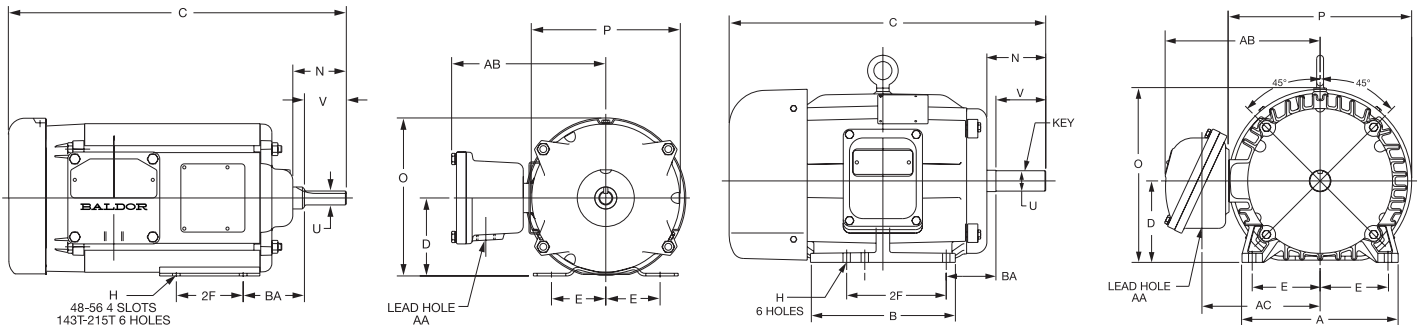

Single Phase, Rolled Steel Construction

NEMA Frame	A	B	D	E	2F	H	N	O	P	U	V	AA	AB	AC	BA
48	5.75	4.00	3.00	2.12	2.75	0.34	1.62	6.10	5.75	0.50	1.50	0.50	6.54	5.00	2.50
(400Type)	6.56	(4.25)	3.50	2.44	3.00	0.34	(2.00)	(6.60)	(5.78)	0.62	1.88	(6.50)	(4.96)	5.38	2.75
56	6.56	4.50	3.50	2.44	3.00	0.34	2.40	7.09	6.69	0.62	1.88	0.50	6.92	5.38	2.75
143T	6.50	5.94	3.50	2.75	4.00	0.34	2.46	7.09	6.69	0.87	2.25	0.75	6.92	5.38	2.25
145T	6.50	5.94	3.50	2.75	5.00	0.34	2.46	7.09	6.69	0.87	2.25	0.75	6.92	5.38	2.25
(500Type)	8.63	6.50	4.50	3.75	(4.50)	0.41	(2.46)	(8.09)	(6.69)	0.87	2.25	(0.50)	(6.92)	(5.38)	2.75
182-4	8.63	6.50	4.50	3.75	5.50	0.41	2.56	8.44	7.88	0.87	2.25	0.75	7.52	5.98	2.75
182T	8.63	6.50	4.50	3.75	4.50	0.41	3.06	8.44	7.88	1.12	2.75	0.75	7.52	5.98	2.75
184T	8.63	6.50	4.50	3.75	5.50	0.41	3.06	8.44	7.88	1.12	2.75	0.75	7.52	5.98	2.75
213	9.50	8.00	5.25	4.25	5.50	0.41	3.44	10.56	9.69(L)	1.12	3.00	0.75	8.37	6.83	3.50
215	9.50	8.00	5.25	4.25	7.00	0.41	3.44	10.56	9.56(M)	1.12	3.00	0.75	8.37	6.83	3.50
213T	9.50	8.00	5.25	4.25	5.50	0.41	3.82	10.03	9.56	1.375	3.38	0.75	8.37	6.83	3.50
215T	9.50	8.00	5.25	4.25	7.00	0.41	3.82	10.03	9.56	1.375	3.38	0.75	8.37	6.83	3.50

Three Phase, Cast Iron Construction

NEMA Frame	A	B	D	E	2F	H	N	O	P	U	V	AA	AB	AC	BA
182T	8.62	8.00	4.50	3.75	4.50	0.41	3.25	11.27	10.08	1.12	2.75	0.75	8.56	6.53	2.75
184T	8.62	8.00	4.50	3.75	5.50	0.41	3.25	11.27	10.08	1.12	2.75	0.75	8.56	6.53	2.75
213T	9.75	8.00	5.25	4.25	5.50	0.41	3.47	10.75	11.00	1.37	3.38	0.75	9.66	7.62	3.50
215T	9.75	8.00	5.25	4.25	7.00	0.41	3.47	10.75	11.00	1.37	3.38	0.75	9.66	7.62	3.50
254T	11.50	11.50	6.25	5.00	8.25	0.53	4.20	12.94	13.44	1.62	4.00	1.25	12.37	9.24	4.25
256T	11.50	11.50	6.25	5.00	10.00	0.53	4.20	12.94	13.44	1.62	4.00	1.25	12.37	9.24	4.25
284TS	12.76	12.75	7.00	5.50	9.50	0.53	3.50	14.75	15.54	1.62	3.25	1.25	16.51	11.57	4.75
286TS	12.76	12.75	7.00	5.50	11.00	0.53	3.50	14.75	15.54	1.62	3.25	1.25	16.51	11.57	4.75
284T	12.76	12.75	7.00	5.50	9.50	0.53	4.88	14.75	15.54	1.87	4.63	1.50	16.51	11.57	4.75
286T	12.76	12.75	7.00	5.50	11.00	0.53	4.88	14.75	15.54	1.87	4.63	1.50	16.51	11.57	4.75
324TS	14.50	14.00	8.00	6.25	10.50	0.66	3.94	16.68	17.40	1.87	3.75	2.00	17.40	12.48	5.25
326TS	14.50	14.00	8.00	6.25	12.00	0.66	3.94	16.68	17.40	1.87	3.75	2.00	17.40	12.48	5.25
324T	14.50	14.00	8.00	6.25	10.50	0.66	5.44	16.68	17.40	2.12	5.25	2.00	17.40	12.48	5.25
326T	14.50	14.00	8.00	6.25	12.00	0.66	5.44	16.68	17.40	2.12	5.25	2.00	17.40	12.48	5.25
364T	17.00	13.50	9.00	7.00	11.25	0.66	6.13	18.50	18.88	2.37	5.88	2.50	17.44	12.75	5.88
365T	17.00	14.50	9.00	7.00	12.25	0.66	6.13	18.50	18.88	2.37	5.88	2.50	17.35	12.75	5.88
404T	19.50	15.25	10.00	8.00	12.75	0.81	7.56	21.00	20.88	2.87	7.25	2.50	18.44	13.75	6.62
405T	19.50	16.75	10.00	8.00	13.75	0.81	7.56	21.00	20.88	2.87	7.25	2.50	18.44	13.75	6.62
444T	21.75	20.25	11.00	9.00	14.50	0.81	8.75	22.94	24.81	3.37	8.50	3.00	23.63	18.31	7.50
445T	21.75	20.25	11.00	9.00	16.50	0.81	8.75	22.94	24.81	3.37	8.50	3.00	23.63	18.31	7.50
447T	21.75	28.75	11.00	9.00	20.00	0.81	8.50	22.94	24.81	3.37	8.50	3.00	27.67	18.62	7.50
449T	21.75	28.75	11.00	9.00	25.00	0.81	8.50	22.94	24.81	3.37	8.50	3.00	27.67	18.62	7.50

Note: Drawings shown are for reference only. Please contact Baldor for a detailed dimensional drawing of the specific motor you require. Drawings may also be available from our website at www.baldor.com

Baldor Explosion Proof AC and DC Motors

Motor Dimensions

C-Face Explosion-Proof Motors

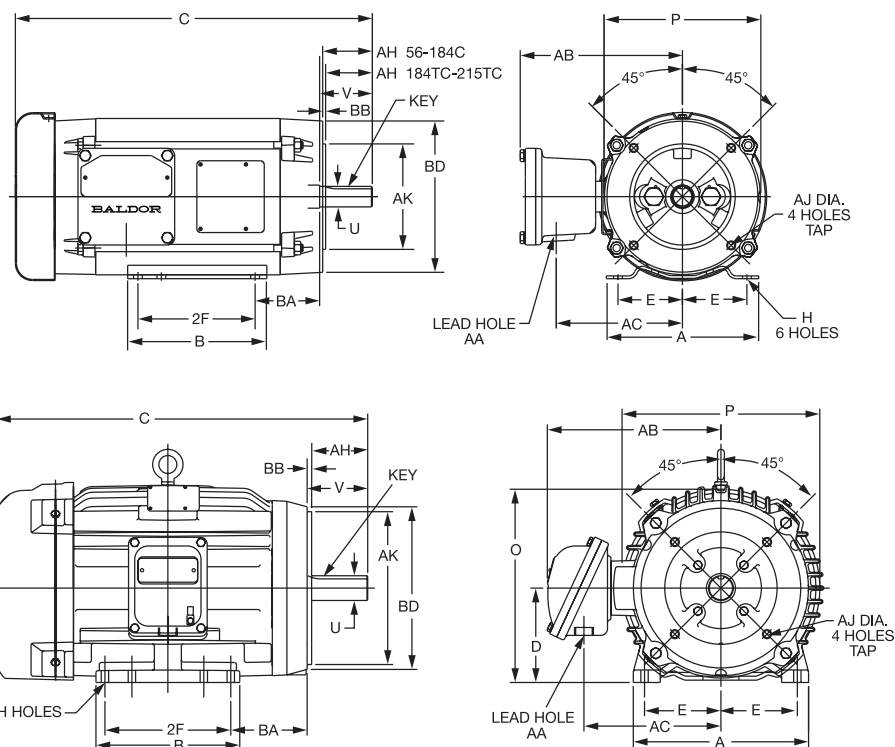

Rolled Steel Construction

NEMA Frame	A	B	D	E	2F	H	O	P	U	V	AA	AB	AC	AH	AJ	AK	BA	BB	BD	Tap
400(Type)	(6.56)	(4.25)	3.50	2.44	3.00	0.34	(6.60)	(5.78)	0.62	1.88	0.50	(6.50)	(4.96)	2.06	5.88	4.50	2.75	0.12	(5.90)	3/8-16
56C	6.50	4.50	3.50	2.44	3.00	0.34	7.09	6.69	0.62	1.88	0.50	6.92	5.38	2.06	5.88	4.50	2.75	0.12	6.46	3/8-16
143TC	6.50	5.94	3.50	2.75	4.00	0.34	7.09	6.69	0.87	2.25	0.75	6.92	5.38	2.12	5.88	4.50	2.75	0.13	6.46	3/8-16
145TC	6.50	5.94	3.50	2.75	5.00	0.34	7.09	6.69	0.87	2.25	0.75	6.92	5.38	2.12	5.88	4.50	2.75	0.13	6.46	3/8-16
182C	8.63	6.50	4.50	3.75	4.50	0.41	8.44	8.00	0.87	2.25	0.75	7.52	5.98	2.12	5.88	4.50	2.75	0.13	6.38	3/8-16
184C	8.63	6.50	4.50	3.75	5.50	0.41	8.44	8.00	0.87	2.25	0.75	7.52	5.98	2.12	5.88	4.50	2.75	0.13	6.38	3/8-16
182TC	8.63	6.50	4.50	3.75	4.50	0.41	9.00	8.03	1.12	2.75	0.75	7.52	5.98	2.62	7.25	8.50	2.75	0.25	8.98	1/2-13
184TC	8.63	6.50	4.50	3.75	5.50	0.41	9.00	8.03	1.12	2.75	0.75	7.52	5.98	2.62	7.25	8.50	2.75	0.25	8.98	1/2-13
213C	9.50	8.00	5.25	4.25	5.50	0.41	10.10	9.69	1.12	3.00	0.75	8.37	6.83	2.75	7.25	8.50	3.50	0.25	9.00	1/2-13
215C	9.50	8.00	5.25	4.25	7.00	0.41	10.10	9.69	1.12	3.00	0.75	8.37	6.83	2.75	7.25	8.50	3.50	0.25	9.00	1/2-13
213TC	9.50	8.00	5.25	4.25	5.50	0.41	10.03	9.69	1.37	3.37	0.75	8.37	6.83	3.12	7.25	8.50	4.25	0.25	9.04	1/2-13
215TC	9.50	8.00	5.25	4.25	7.00	0.41	10.03	9.69	1.37	3.37	0.75	8.37	6.83	3.12	7.25	8.50	4.25	0.25	9.04	1/2-13

Cast Iron Construction

NEMA Frame	A	B	D	E	2F	H	O	P	U	V	AA	AB	AC	AH	AJ	AK	BA	BB	BD	Tap
213TC	9.75	8.00	5.25	4.25	5.50	0.41	10.75	11.00	1.37	3.38	0.75	9.66	7.62	3.12	7.25	8.50	4.25	0.25	9.05	1/2-13
215TC	9.75	8.00	5.25	4.25	7.00	0.41	10.75	11.00	1.37	3.38	0.75	9.66	7.62	3.12	7.25	8.50	4.25	0.25	9.05	1/2-13
254TC	11.50	11.50	6.25	5.00	8.25	0.53	12.94	13.44	1.62	4.00	1.25	11.19	8.57	3.75	7.25	8.50	4.75	0.25	9.13	1/2-13
256TC	11.50	11.50	6.25	5.00	10.00	0.53	12.94	13.44	1.62	4.00	1.25	11.19	8.57	3.75	7.25	8.50	4.75	0.25	9.13	1/2-13
284TCS	12.76	12.75	7.00	5.50	9.50	0.53	14.75	15.54	1.62	3.25	1.25	14.37	10.69	3.00	9.00	10.50	4.75	0.25	11.15	1/2-13
286TCS	12.76	12.75	7.00	5.50	11.00	0.53	14.75	15.54	1.62	3.25	1.25	14.37	10.69	3.00	9.00	10.50	4.75	0.25	11.15	1/2-13
284TC	12.76	12.75	7.00	5.50	9.50	0.53	14.75	15.54	1.87	4.62	1.25	14.37	10.69	4.37	9.00	10.50	4.75	0.25	11.15	1/2-13
286TC	12.76	12.75	7.00	5.50	11.00	0.53	14.75	15.54	1.87	4.62	1.25	14.37	10.69	4.37	9.00	10.50	4.75	0.25	11.15	1/2-13
324TC	14.50	14.00	8.00	6.25	10.50	0.65	16.68	17.46	2.12	5.25	1.50	15.25	11.60	5.00	11.00	12.50	5.25	0.25	13.38	5/8-11
326TC	14.50	14.00	8.00	6.25	12.00	0.65	16.68	17.46	2.12	5.25	1.50	15.25	11.60	5.00	11.00	12.50	5.25	0.25	13.38	5/8-11

Note: Drawings shown are for reference only. Please contact Baldor for a detailed dimensional drawing of the specific motor you require. Drawings may also be available from our website at www.baldor.com

Baldor Explosion Proof AC and DC Motors

Motor Dimensions

Brake Motors, C-Face Foot Mounted, Explosion Proof , Three Phase

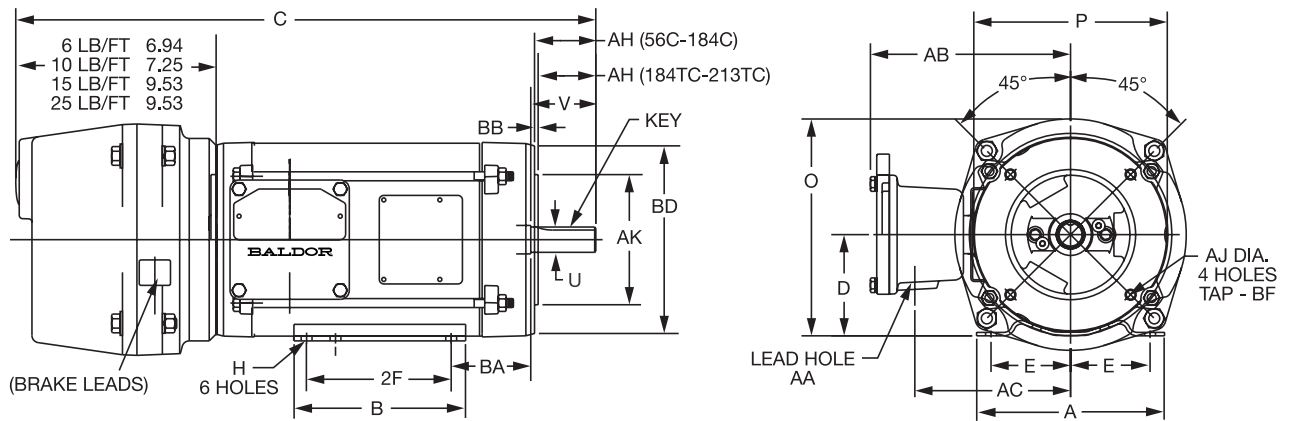

NEMA Frame	A	B	D	E	2F	H	O	P	U	V	AA	AB	AC	AH	AJ	AK	BA	BB	BD	Tap
56C	6.50	4.50	3.50	2.44	3.00	0.34	7.50	6.69	0.62	1.87	0.50	6.92	5.38	2.06	5.88	4.50	2.75	0.13	6.49	3/8-16
143TC	6.50	5.94	3.50	2.75	4.00	0.34	7.50	6.69	0.87	2.25	0.75	6.92	5.38	2.12	5.88	4.50	2.75	0.13	6.49	3/8-16
145TC	6.50	5.94	3.50	2.75	5.00	0.34	7.50	6.69	0.87	2.25	0.75	6.92	5.38	2.12	5.88	4.50	2.75	0.13	6.49	3/8-16
182TC	8.63	6.50	4.50	3.75	4.50	0.41	8.99	8.03	1.12	2.75	0.75	7.52	5.98	2.62	7.25	8.50	3.50	0.25	8.98	1/2-13
184TC	8.63	6.50	4.50	3.75	5.50	0.41	8.99	8.03	1.12	2.75	0.75	7.52	5.98	2.62	7.25	8.50	3.50	0.25	8.98	1/2-13
213TC	9.50	8.00	5.25	4.25	5.50	0.41	10.03	9.69	1.37	3.37	0.75	8.37	6.83	3.12	7.25	8.50	4.25	0.25	9.00	1/2-13
215TC	9.50	8.00	5.25	4.25	7.00	0.41	10.03	9.69	1.37	3.37	0.75	8.37	6.83	3.12	7.25	8.50	4.25	0.25	9.00	1/2-13

Note: Drawings shown are for reference only. Please contact Baldor for a detailed dimensional drawing of the specific motor you require. Drawings may also be available from our website at www.baldor.com

Baldor Explosion Proof AC and DC Motors

Motor Dimensions

Jet Pump Explosion-Proof Motors 56J Frame

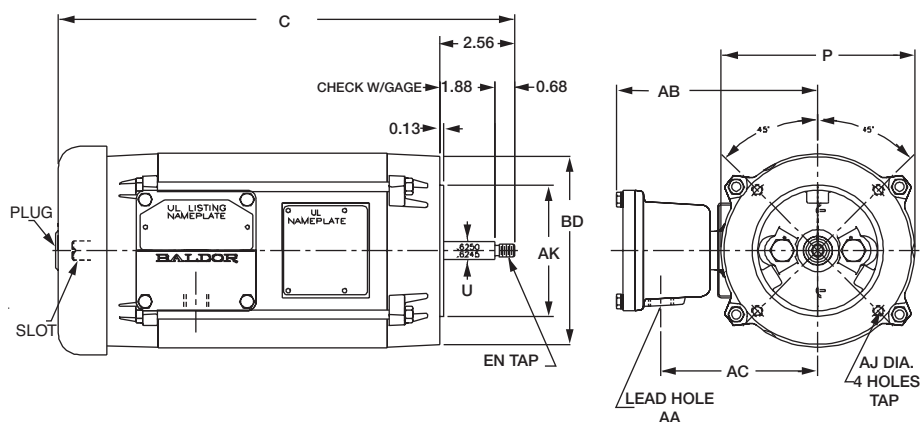

Close-Coupled Pump Explosion-Proof Motors

143JM-2 ISJM Frame

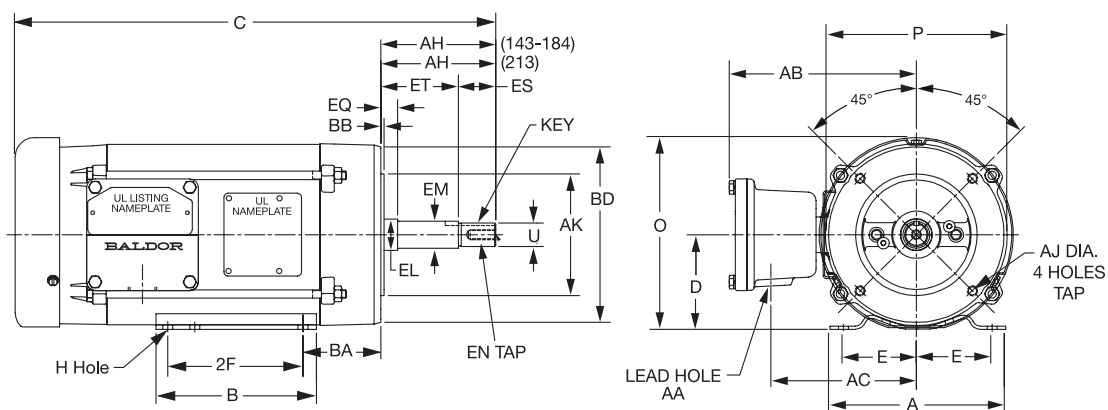

Rolled Steel Construction

NEMA Frame	A	B	D	E	2F	H	O	P	U	AA	AB	AC	AJ	AK	BA	BB	BD	Tap
(400Type)	-	-	-	-	-	-	-	(5.61)	0.62	0.50	(6.53)	(5.00)	5.88	4.50	-	0.12	(5.91)	3/8-16
56J	-	-	-	-	-	-	-	6.68	0.62	0.50	6.90	5.38	5.88	4.50	-	0.12	6.50	3/8-16
143JM	6.50	5.94	3.50	2.75	4.00	0.34	7.81	6.69	0.87	0.75	6.92	5.38	5.88	4.50	2.88	0.13	6.49	3/8-16
145JM	6.50	5.94	3.50	2.75	5.00	0.34	7.81	6.69	0.87	0.75	6.92	5.38	5.88	4.50	2.88	0.13	6.49	3/8-16
182JM	8.63	6.50	4.50	3.75	4.50	0.41	8.99	7.88	0.87	0.75	7.52	5.98	5.88	4.50	3.50	0.12	6.28	3/8-16
184JM	8.63	6.50	4.50	3.75	5.50	0.41	8.99	7.88	0.87	0.75	7.52	5.98	5.88	4.50	3.50	0.12	6.28	3/8-16
213JM	9.50	8.00	5.25	4.25	5.50	0.41	10.99	9.69	0.87	0.75	8.37	6.83	7.25	8.50	4.25	0.25	9.04	1/2-13
215JM	9.50	8.00	5.25	4.25	7.00	0.41	10.99	9.69	0.87	0.75	8.37	6.83	7.25	8.50	4.25	0.25	9.04	1/2-13

NEMA Frame	AH	EL	EM	EN	EQ	ES	ET
143JM	4.28	1.16	1.00	0.88	0.64	1.39	2.89
145JM	4.28	1.16	1.00	0.88	0.64	1.39	2.89
182JM	4.28	1.25	1.00	0.88	0.64	1.39	2.89
184JM	4.28	1.25	1.00	0.88	0.64	1.39	2.89
213JM	4.25	1.25	1.00	0.88	0.62	1.37	2.88
215JM	4.25	1.25	1.00	0.88	0.62	1.37	2.88

Note: Drawings shown are for reference only. Please contact Baldor for a detailed dimensional drawing of the specific motor you require. Drawings may also be available from our website at www.baldor.com

Baldor Explosion Proof AC and DC Motors

Motor Dimensions

Close Coupled Pump – Drill Rig Duty 182JP Frame

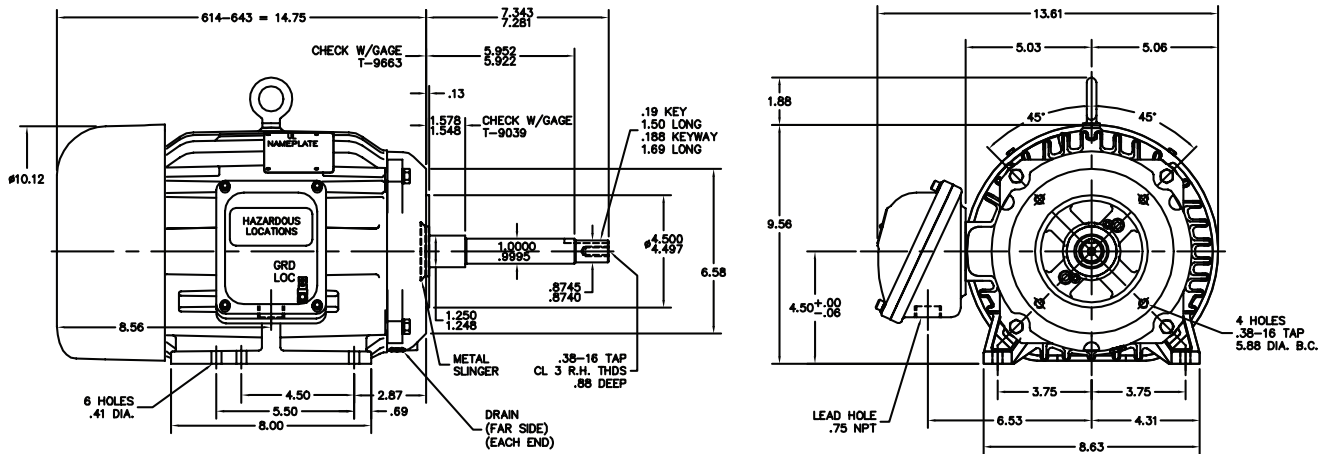

Close Coupled Pump – Drill Rig Duty – One Size Smaller Flange J Shaft 184JP Mounting

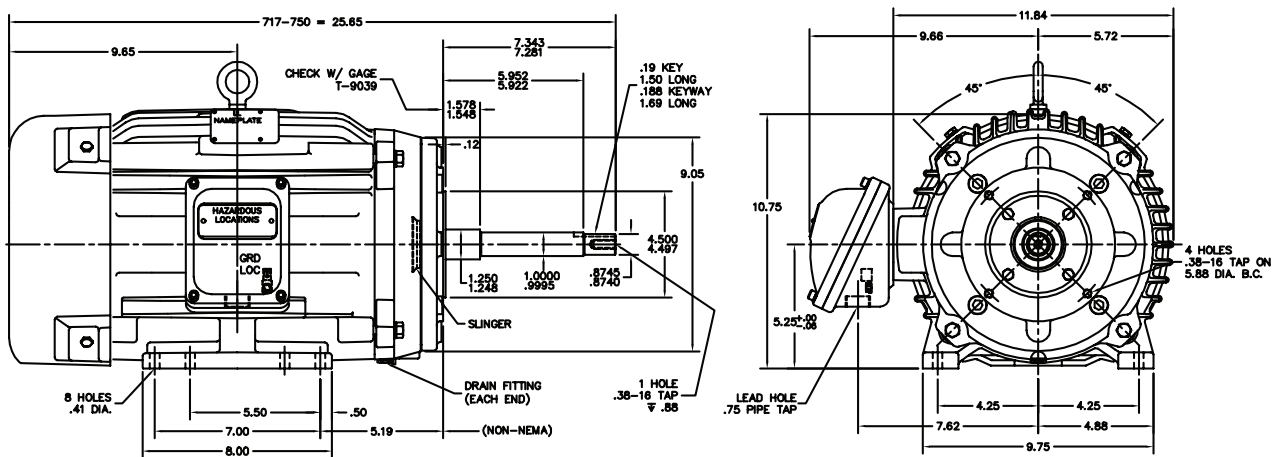

Note: Drawings shown are for reference only. Please contact Baldor for a detailed dimensional drawing of the specific motor you require. Drawings may also be available from our website at www.baldor.com

Baldor Explosion Proof AC and DC Motors

Motor Dimensions

Submersible 140TY-320TY Frames

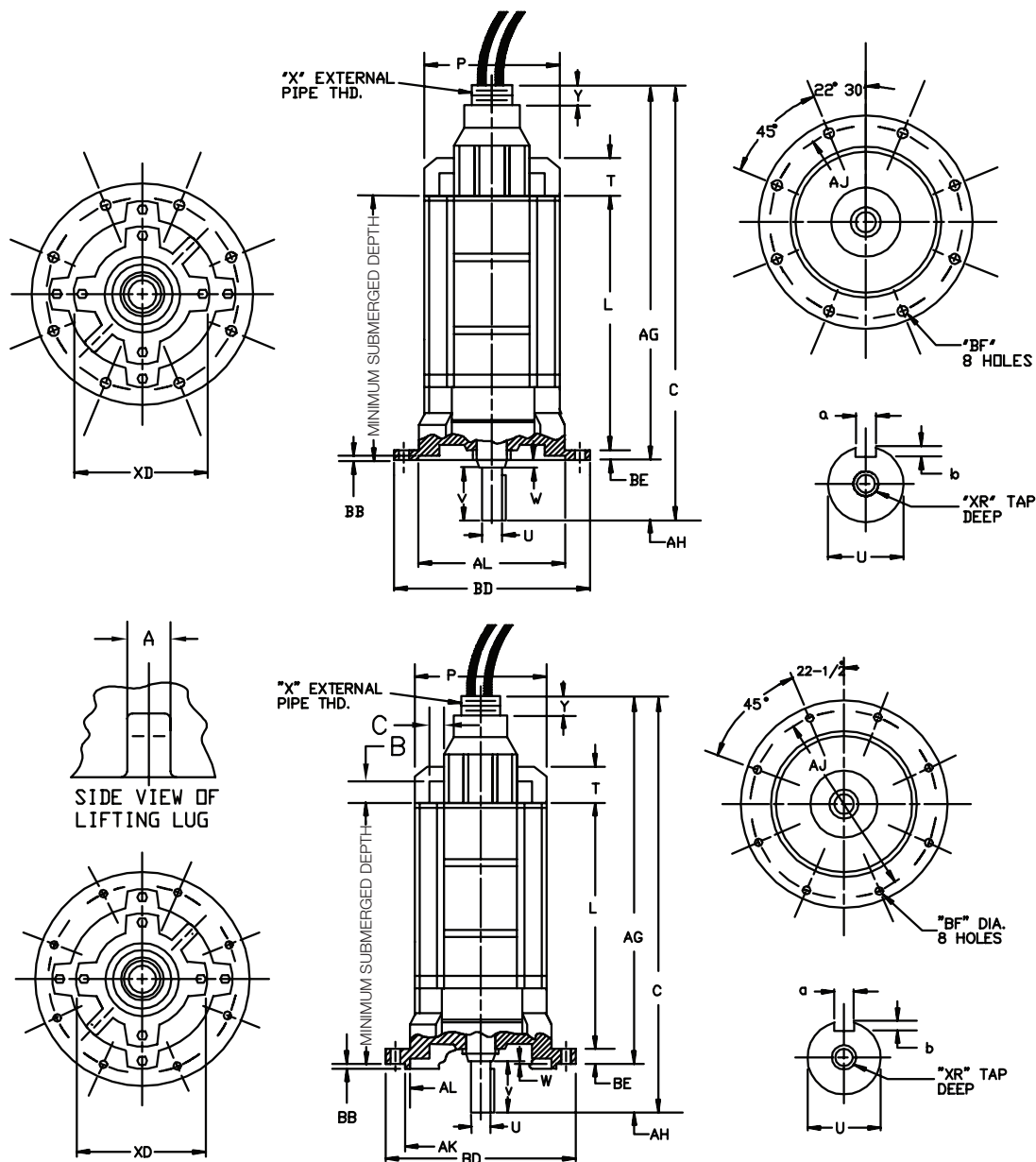

Dimensions are in inches

Frame	C	L	P	T	U	V	W	AG	AH	AJ	AK	AL
140TY	25.44	15.38	8.00	2.25	.8750	1.25	.31	23.88	1.59	10.00		9.125
180TY	26.66	16.50	9.62	2.25	1.2500	2.00	.28	24.38	2.28	11.50		10.625
210TY	31.69	21.12	11.50	2.25	1.4380	2.00	.44	30.12	1.56	14.12	13.125	12.00
250TY	38.53	24.12	12.75	3.50	1.750	3.31	.28	35.50	3.03	16.00	15.000	14.00
320TY	43.12	24.69	15.75	4.25	2.500	3.19	2.12	37.81	5.37	17.25	16.000	15.25

Frame	BD	BE	BF	XR	X	Lead Connection		BB	B.E. Keyway			Weight
						Y	XD		A	B	Length	
140TY	11.062	.75	.44	3/8-16	2-1/2-8	1.25	5.50	.12	.187	.09	1.25	160
180TY	12.375	.75	.56	1/2-13	2-1/2-8	1.25	6.75	.12	.250	.12	1.12	200
210TY	15.250	.75	.56	5/8-11	2-1/2-8	1.25	7.75	.25	.375	.19	1.12	315
250TY	17.000	.88	.69	5/8-11	2-1/2-8	1.25	7.75	.25	.375	.19	2.25	750
320TY	18.750	.88	.69	3/4-10	3-8	1.25	10.88	.25	.500	.25	3.00	1150

Note: Drawings shown are for reference only. Please contact Baldor for a detailed dimensional drawing of the specific motor you require. Drawings may also be available from our website at www.baldor.com

Baldor Explosion Proof AC and DC Motors

Motor Dimensions

Submersible 180TY-320TY Frames

One Size Smaller Flange & Shaft

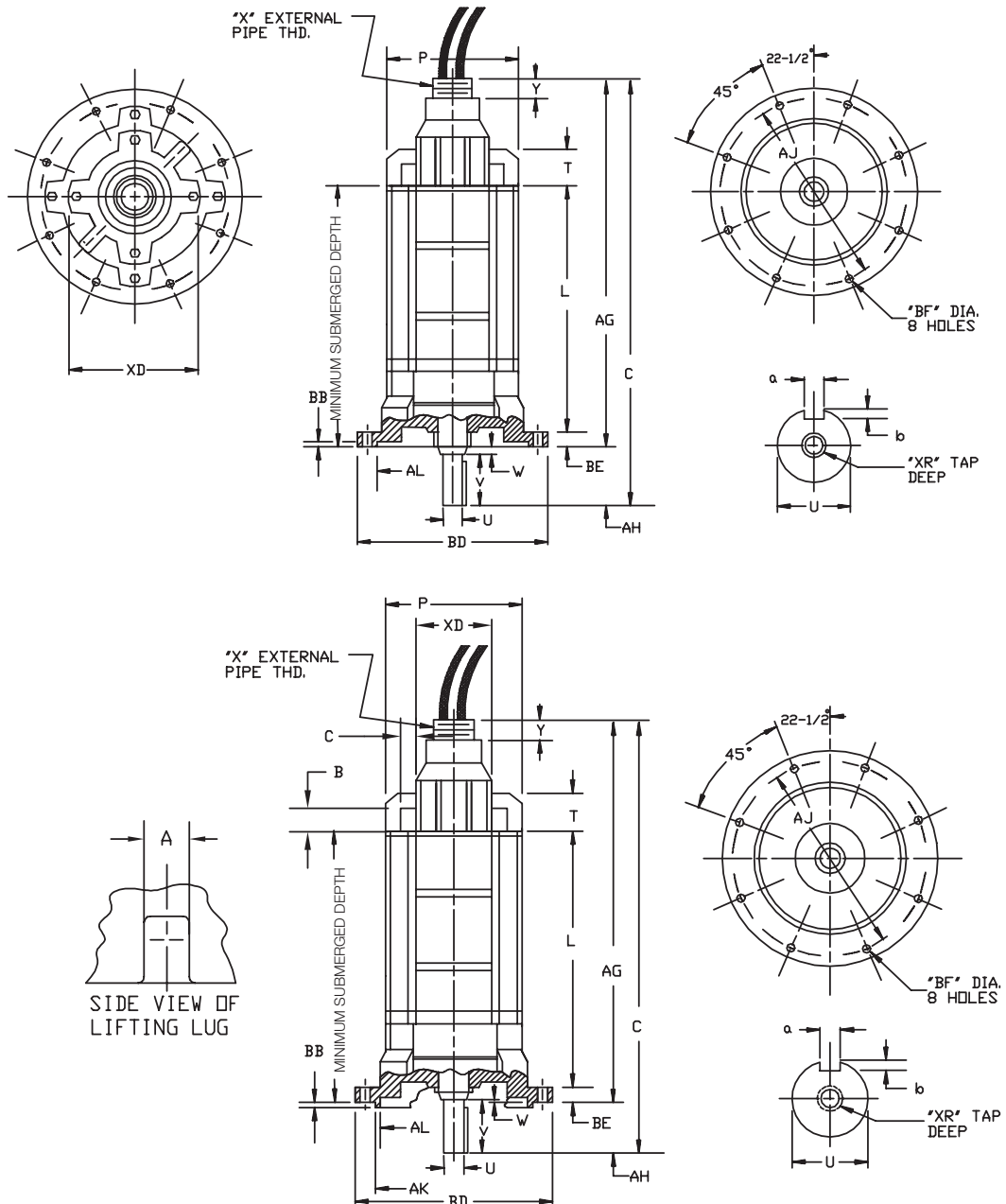

Dimensions are in inches

Frame	C	L	P	T	U	V	W	AG	AH	AJ	AK	AL
180TY	25.94	16.50	9.62	2.25	.8750	1.25	.31	24.38	1.56	10.00		91.25
210TY	32.41	24.12	11.20	2.25	1.2500	2.00	.25	30.12	2.28	11.50		10.625
250TY	37.06	24.12	12.75	3.50	1.438	2.00	.25	35.50	1.56	14.12	13.125	12.00
320TY	42.50	26.31	16.00	4.25	1.750	3.31	.25	39.25	3.03	16.00	15.000	14.25

Frame	BD	BE	BF	XR	X	Lead Connection		BB	B.E. Keyway		Weight	
						Y	XD		A	B Length		
180TY	11.062	.75	.44	3/18-16	2-1/2-8	1.25	6.75	.12	.187	.09	1.12	200
210TY	12.375	.75	.56	1/2-13	2-1/2-8	1.25	7.75	.12	.250	.12	1.12	315
250TY	15.25	1.00	.56	5/8-11	2-1/2-8	1.25	7.75	.25	.375	.19	1.12	750
320TY	17.00	.88	.69	5/8-11	3-8	1.25	10.88	.25	.375	.19	3.00	1150

Note: Drawings shown are for reference only. Please contact Baldor for a detailed dimensional drawing of the specific motor you require. Drawings may also be available from our website at www.baldor.com

Baldor Explosion Proof AC and DC Motors

Motor Dimensions

Submersible 360TY-L360TY Frames

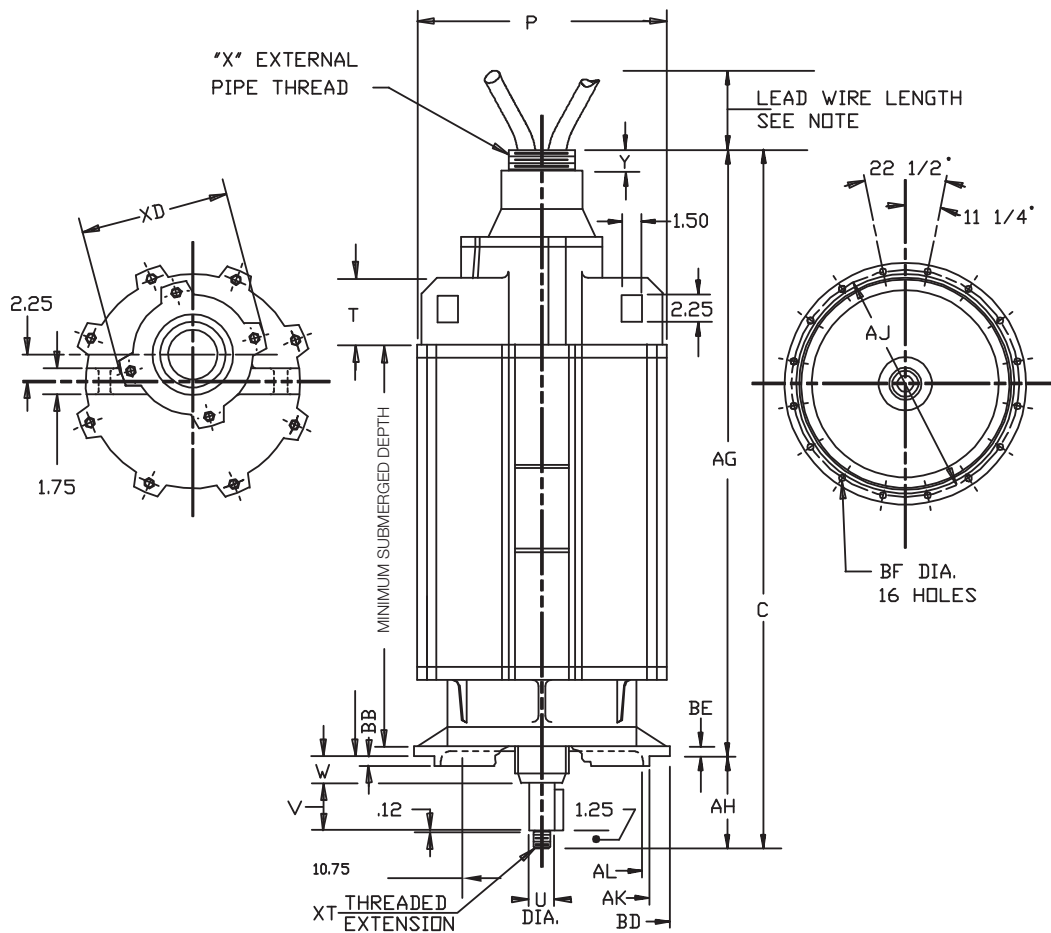

Dimensions are in inches

Frame	C	L	P	T	U	V	W	AG	AH	AJ	AK	AL
180TY	47.1	31.25	18.38	4.25	2.4997	3.19	2.12	43.25	6.56	18.75	17.500	15.25
210TY	49.1	33.25	18.38	4.25	2.4997	3.19	2.12	45.25	6.56	18.75	17.500	15.25

Frame	BB	BD	BE	BF	XT	Lead Connection			B.E. Keyway	
						X	Y	XD	SQ.	LGTH
180TY	.25	20.25	1.12	.69	1-1/2-12	3-8	1.25	10.88	.50	3.00
210TY	.25	20.25	1.12	.69	1-1/2-12	3-8	1.25	10.88	.50	3.00

Note: Drawings shown are for reference only. Please contact Baldor for a detailed dimensional drawing of the specific motor you require. Drawings may also be available from our website at www.baldor.com

Baldor Explosion Proof AC and DC Motors

Motor Dimensions

TEFC Inverter Drive® Explosion-Proof Motors

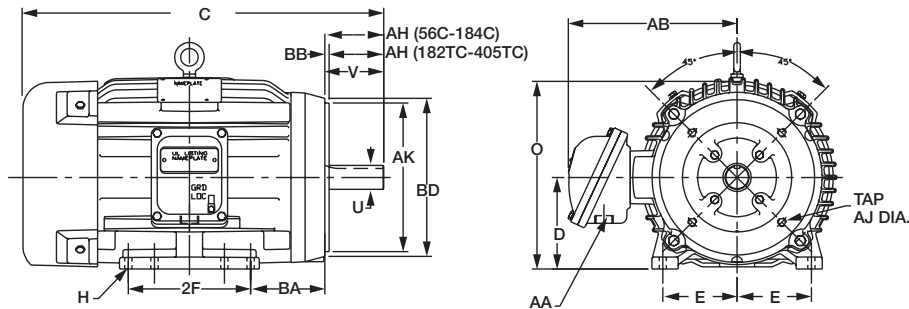

Rolled Steel Construction

NEMA Frame	D	E	2F	H	O	U	V	AA	AB	AH	AJ	AK	BA	BB	BD	Tap
56C	3.50	2.44	3.00	0.34	7.09	0.625	1.88	0.50 NPT	6.92	2.06	5.88	4.50	2.75	0.13	6.46	3/8-16
143TC	3.50	2.75	4.00	0.34	7.09	0.875	2.25	0.75 NPT	6.92	2.12	5.88	4.50	2.75	0.13	6.46	3/8-16
145TC	3.50	2.75	5.00	0.34	7.09	0.875	2.25	0.75 NPT	6.92	2.12	5.88	4.50	2.75	0.13	6.46	3/8-16

Cast Iron Construction

NEMA Frame	D	E	2F	H	O	U	V	AA	AB	AH	AJ	AK	BA	BB	BD	Tap
182TC	4.50	3.75	4.50	0.41	9.56	1.125	2.75	0.75	8.55	2.62	7.25	8.50	3.50	0.13	8.96	1/2-13
184TC	4.50	3.75	5.50	0.41	9.56	1.125	2.75	0.75	8.55	2.62	7.25	8.50	3.50	0.13	8.96	1/2-13
213TC	5.25	4.25	5.50	0.41	10.75	1.375	3.37	0.75	9.66	3.12	7.25	8.50	4.25	0.25	9.05	1/2-13
215TC	5.25	4.25	7.00	0.41	10.75	1.375	3.37	0.75	9.66	3.12	7.25	8.50	4.25	0.25	9.05	1/2-13
254TC	6.25	5.00	8.25	0.53	12.94	1.625	4.00	1.25	11.25	3.75	7.25	8.50	4.75	0.25	9.13	1/2-13
256TC	6.25	5.00	10.00	0.53	12.94	1.625	4.00	1.25	11.25	3.75	7.25	8.50	4.75	0.25	9.13	1/2-13

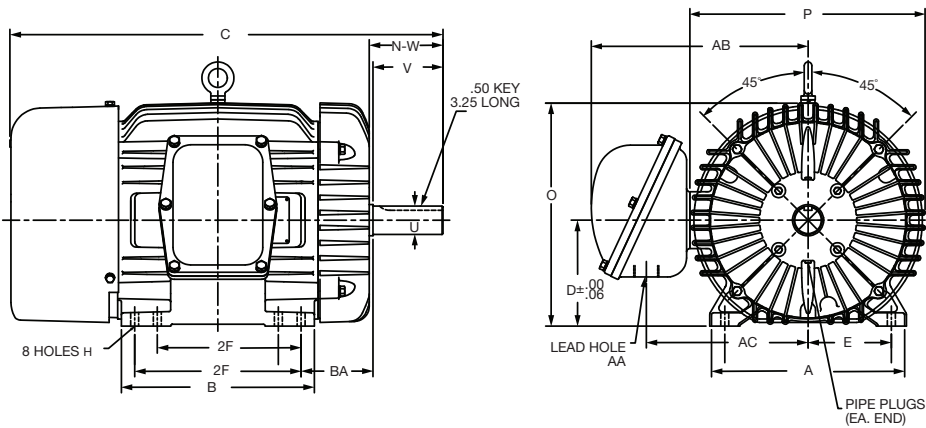

Cast Iron Construction (Non-C-Face)

NEMA Frame	A	B	D	E	2F	H	Key	N	O	P	U	V	AA	AB	AC	BA
254T	11.50	11.50	6.25	5.00	8.25	0.53	0.38	4.20	12.94	13.38	1.625	4.00	1.25 NPT	11.25	8.57	4.25
256T	11.50	11.50	6.25	5.00	10.00	0.53	0.38	4.20	12.94	13.38	1.625	4.00	1.25 NPT	11.25	8.57	4.25
284T	12.76	12.75	7.00	5.50	9.50	0.53	0.50	4.88	14.74	15.54	1.875	4.63	1.25 NPT	14.32	10.69	4.88
286T	12.76	12.75	7.00	5.50	11.00	0.53	0.50	4.88	14.74	15.54	1.875	4.63	1.25 NPT	14.32	10.69	4.88
324T	14.50	14.00	8.00	6.25	10.50	0.65	0.50	5.44	16.68	17.40	2.125	5.25	1.50 NPT	15.23	11.60	5.44
326T	14.50	14.00	8.00	6.25	12.00	0.65	0.50	5.44	16.68	17.40	2.125	5.25	1.50 NPT	15.23	11.60	5.44
364T	16.50	14.50	9.00	7.00	11.25	0.65	0.62	6.13	18.44	19.13	2.375	5.88	3.00 NPT	17.60	13.00	6.13
365T	16.50	14.50	9.00	7.00	12.25	0.65	0.62	6.13	18.44	19.13	2.375	5.88	3.00 NPT	17.60	13.00	6.13
405T	18.88	16.63	10.00	8.00	12.25	0.81	0.75	7.56	20.88	21.25	2.875	7.25	2.50 NPT	18.73	14.13	6.62
	18.88	16.63	10.00	8.00	13.75	0.81	0.75	7.56	20.88	21.25	2.875	7.25	2.50 NPT	18.73	14.13	6.62

Note: Drawings shown are for reference only. Please contact Baldor for a detailed dimensional drawing of the specific motor you require. Drawings may also be available from our website at www.baldor.com

Baldor Explosion Proof AC and DC Motors

Motor Dimensions

SCR Drive Shunt Wound DC Explosion-Proof Motors

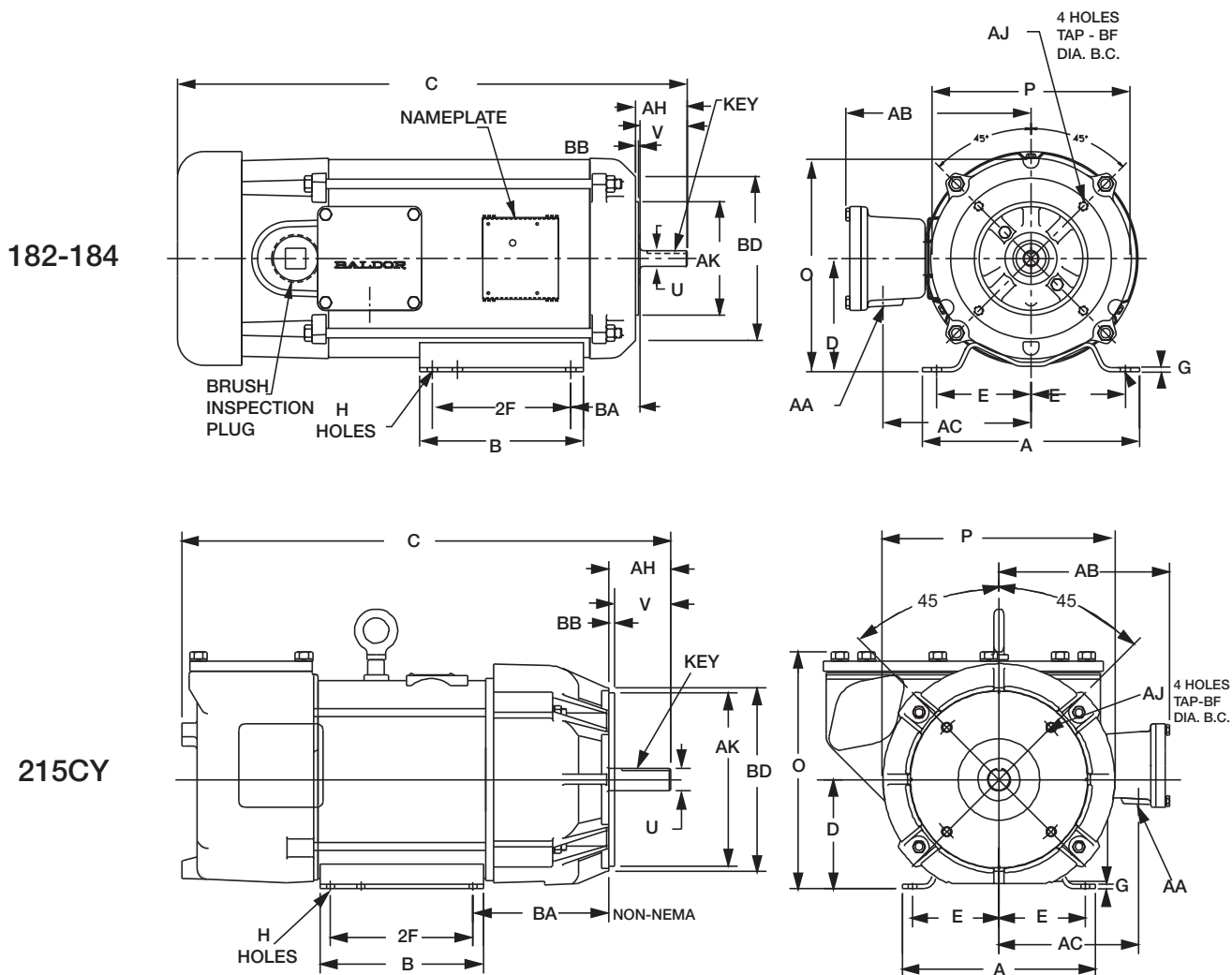

NEMA Frame	Type	C	BA	E	2F	G	H	U	V	Key	AH	A	B	D	O	P
182CZ	3623D	18.61	2.75	3.75	4.50/5.50	0.16	0.41	0.62	1.88	0.19	2.06	8.63	6.50	4.50	8.44	7.86
182C	3623D	18.68	2.75	3.75	4.50/5.50	0.16	0.41	0.87	2.25	0.19	2.12	8.63	6.50	4.50	8.44	7.86
	3636D	20.30	2.75	3.75	4.50/5.50	0.16	0.41	0.87	2.25	0.19	2.12	8.63	6.50	4.50	8.44	7.86
184C	3646D	21.56	2.75	3.75	4.50/5.50	0.16	0.41	0.87	2.25	0.19	2.12	8.63	6.50	4.50	8.44	7.86
215CY	7544D	23.99	6.69	4.25	5.50/7.00	0.81	0.41	1.12	2.75	0.25	3.00	9.50	8.00	5.35	11.58	13.75

NEMA Frame	Type	AA	AB	AC	AJ	AK	BB	BD	BF
182CZ	3623D	0.75	7.35	5.88	5.88	4.50	0.12	6.51	3/8-16
182C	3623D	0.75	7.35	5.88	5.88	4.50	0.12	6.51	3/8-16
	3636D	0.75	7.35	5.88	5.88	4.50	0.12	6.51	3/8-16
184C	3646D	0.75	7.35	5.88	5.88	4.50	0.12	6.51	3/8-16
215CY	7544D	0.75	8.62	6.84	7.25	8.50	0.25	9.00	1/2-13

Note: Drawings shown are for reference only. Please contact Baldor for a detailed dimensional drawing of the specific motor you require. Drawings may also be available from our website at www.baldor.com

Baldor Explosion Proof AC and DC Motors

Motor Dimensions

SCR Drive Permanent Magnet DC Explosion-Proof Motors

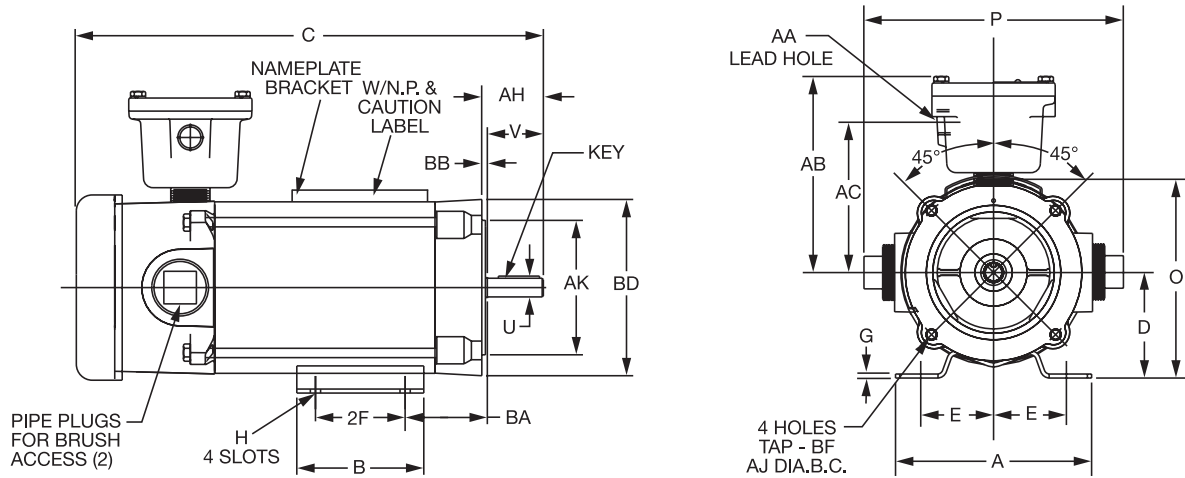

NEMA Frame	Type	C	BA	E	2F	G	H	U	V	Key	AH	A	B	D	O	P
56C	3413P	13.87	2.75	2.44	3.00	0.25	0.34 Slot (4)	0.62	1.87	0.19	2.06	6.56	4.25	3.50	6.34	8.47
	3420P	14.87	2.75	2.44	3.00	0.25	0.34 Slot (4)	0.62	1.87	0.19	2.06	6.56	4.25	3.50	6.34	8.47
	3428P	14.87	2.75	2.44	3.00	0.25	0.34 Slot (4)	0.62	1.87	0.19	2.06	6.56	4.25	3.50	6.34	8.47
	3435P	15.87	2.75	2.44	3.00	0.25	0.34 Slot (4)	0.62	1.87	0.19	2.06	6.56	4.25	3.50	6.34	8.47
56C	3536P	18.36	2.75	2.44	3.00	0.12	0.34 Slot (4)	0.62	1.88	0.19	2.06	6.50	4.50	3.50	7.09	9.32
145TC	3548P	19.43	2.75	2.75	4.00	0.25	0.34 Slot (6)	0.87	2.25	0.19	2.13	6.50	5.94	3.50	7.09	9.32
	3548P	19.43	2.75	2.75	5.00	0.25	0.34 Slot (6)	0.87	2.25	0.19	2.13	6.50	5.94	3.50	7.09	9.32

NEMA Frame	Type	AA	AB	AC	AJ	AK	BB	BD	BF
56C	3413P	0.50 NPT	6.57	5.03	5.88	4.50	0.12	5.90	3/8-16
	3420P	0.50 NPT	6.57	5.03	5.88	4.50	0.12	5.90	3/8-16
	3428P	0.50 NPT	6.57	5.03	5.88	4.50	0.12	5.90	3/8-16
56C	3536P	0.75 NPT	6.76	5.25	5.88	4.50	0.12	6.46	3/8-16
145TC	3548P	0.75 NPT	6.76	5.25	5.88	4.50	0.12	6.46	3/8-16

Note: Drawings shown are for reference only. Please contact Baldor for a detailed dimensional drawing of the specific motor you require. Drawings may also be available from our website at www.baldor.com

Baldor Explosion Proof AC and DC Motors Connection Diagrams

CD0001

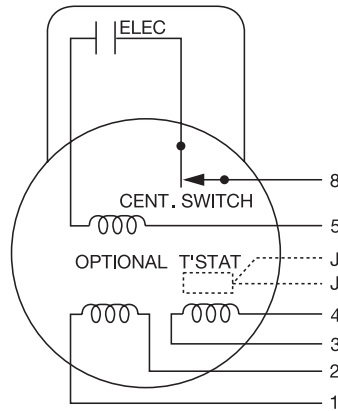

VOLT		LINE A	LINE B	JOIN
HIGH	STD	1	4,5	2,3,8
HIGH	OPP	1	4,8	2,3,5
LOW	STD	1,3,8	2,4,5	—
LOW	OPP	1,3,5	2,4,8	—

CD0005 & 416820-1

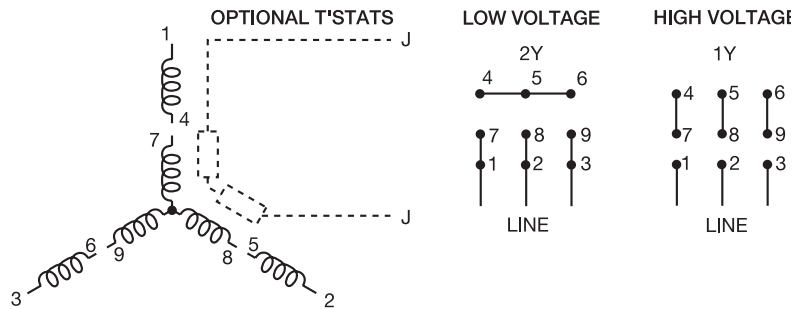

CD0006, 416820-24 & 416820-25

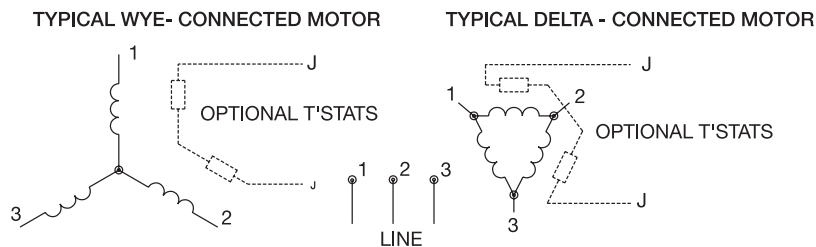

Baldor Explosion Proof AC and DC Motors Connection Diagrams

CD0007

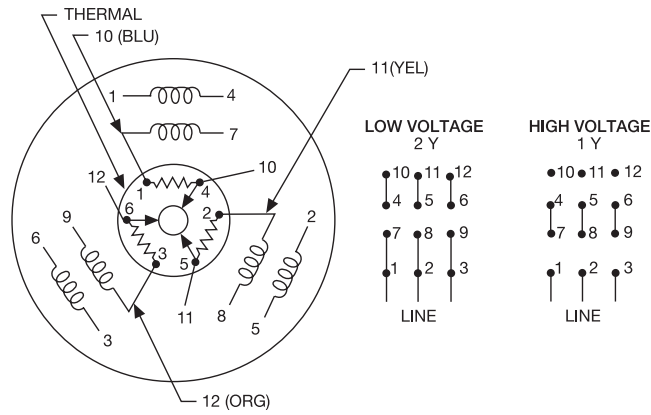

CD0008

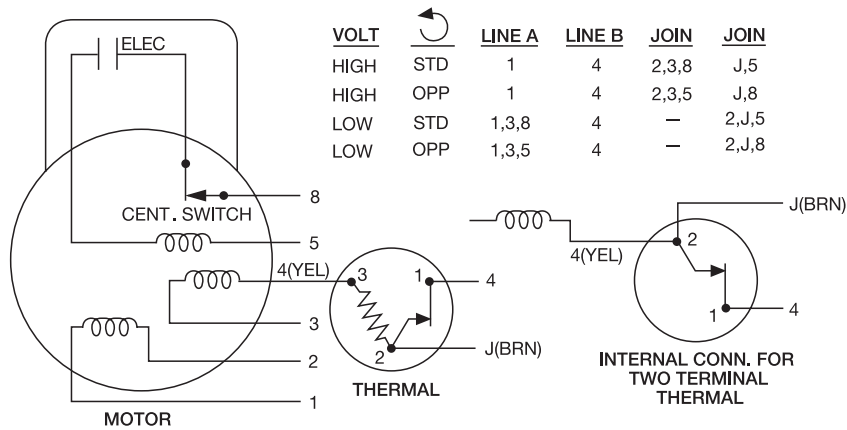

CD0017A02

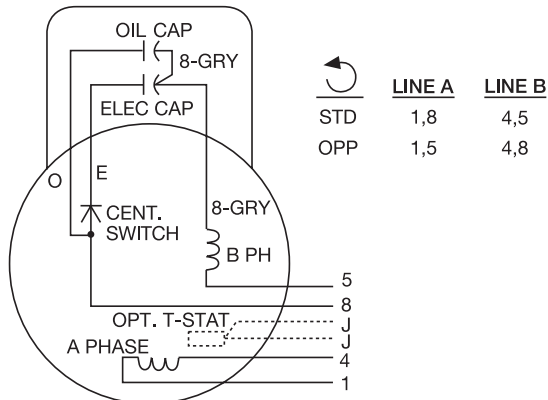

Baldor Explosion Proof AC and DC Motors Connection Diagrams

CD0044

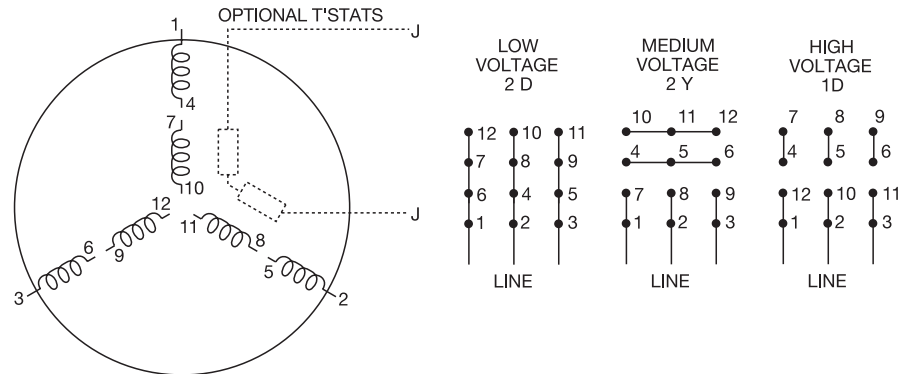

CD0076

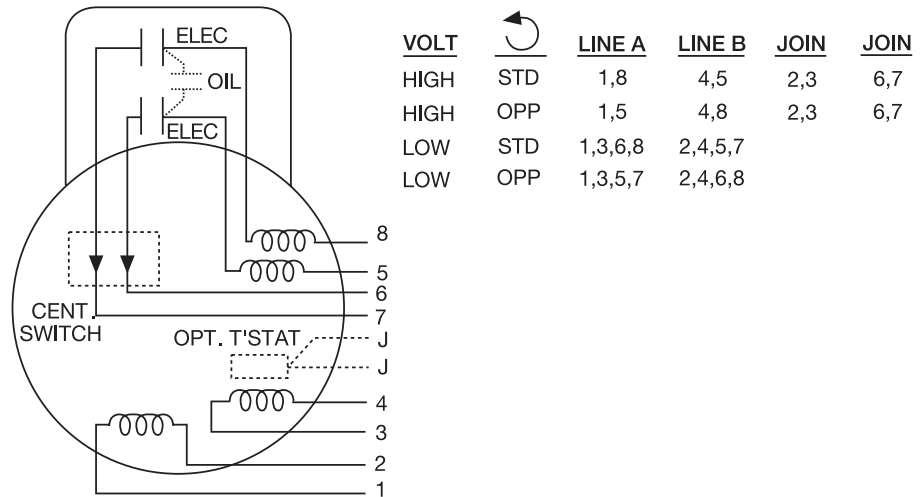

CD0180 & 416820-2

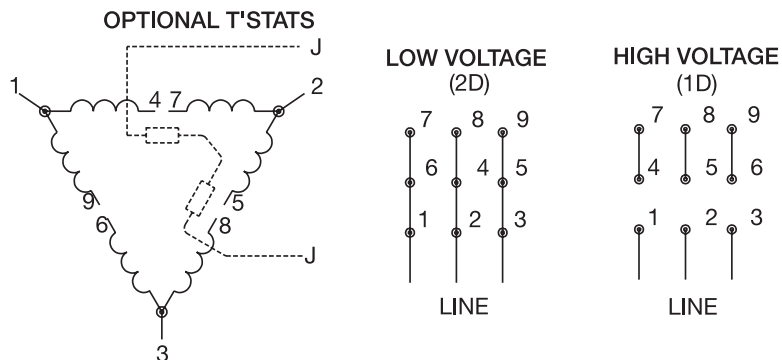

Baldor Explosion Proof AC and DC Motors Connection Diagrams

CD0194

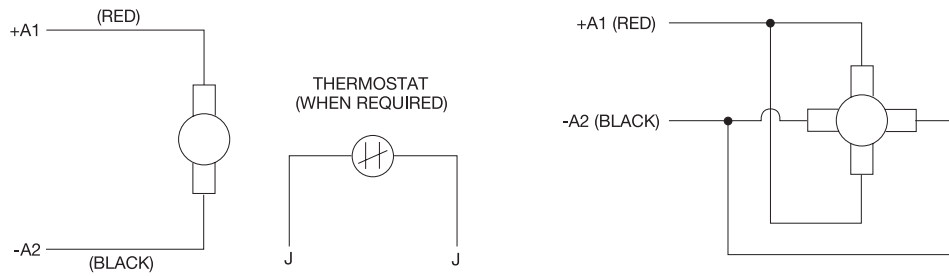

CD0565

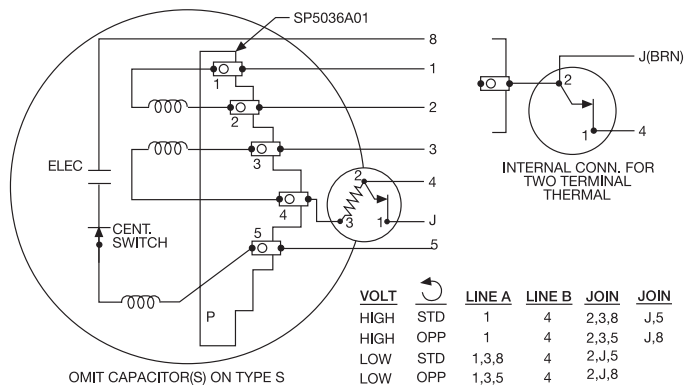

CD0860

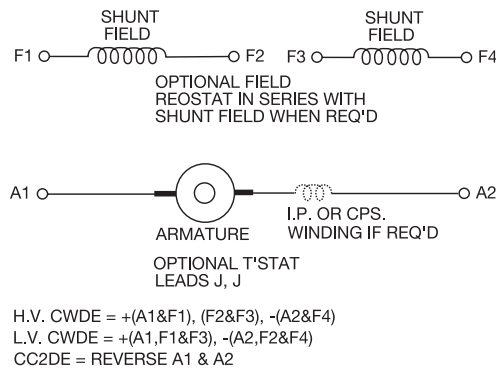

CD0885

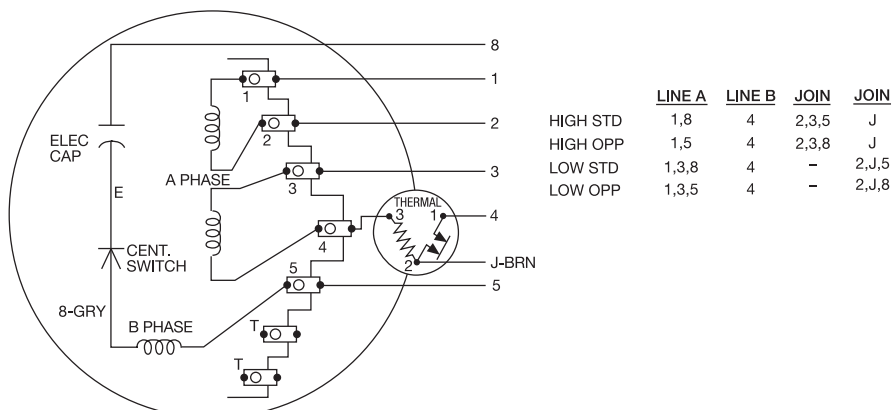

Baldor Explosion Proof AC and DC Motors Connection Diagrams

416820-36

STANDARD 3 LEAD CONNECTED

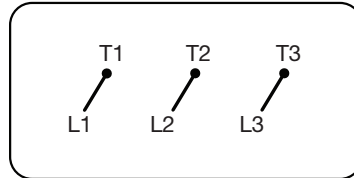

416820-101

A-C MOTOR CONNECTION DIAGRAM

SINGLE PHASE CAPACITOR START INDUCTION RUN
SINGLE VOLTAGE SUMP PUMP MOTOR CONTROL BOX

WIRING DIAGRAM FOR SINGLE PHASE CAPACITOR START INDUCTION RUN SUMP PUMP MOTOR CONTROL BOX
SINGLE VOLTAGE CLOCKWISE AND COUNTERCLOCKWISE ROTATION (SEE NOTE 1)

THIS CONTROL BOX CONTAINS MOTOR STARTING WINDING CAPACITORS FOR ONE SPECIFIC MOTOR DESIGN AND IS NOT USABLE WITH A MOTOR HAVING A DIFFERENT DESIGN. THIS CONTROL BOX DOES NOT INCLUDE THE NECESSARY MOTOR STARTER WHICH SHOULD BE CONNECTED IN THE POWER CIRCUIT TO THIS CONTROL. ALSO, THIS CONTROL BOX DOES NOT INCLUDE THE NECESSARY INDUCTION RELAY WHICH MUST BE USED IN THE MOISTURE SENSOR CIRCUIT. CONNECT THE MOTOR AND CONTROL BOX FOR THE DESIRED ROTATION ACCORDING TO THE WIRING DIAGRAM AND NOTES BELOW.

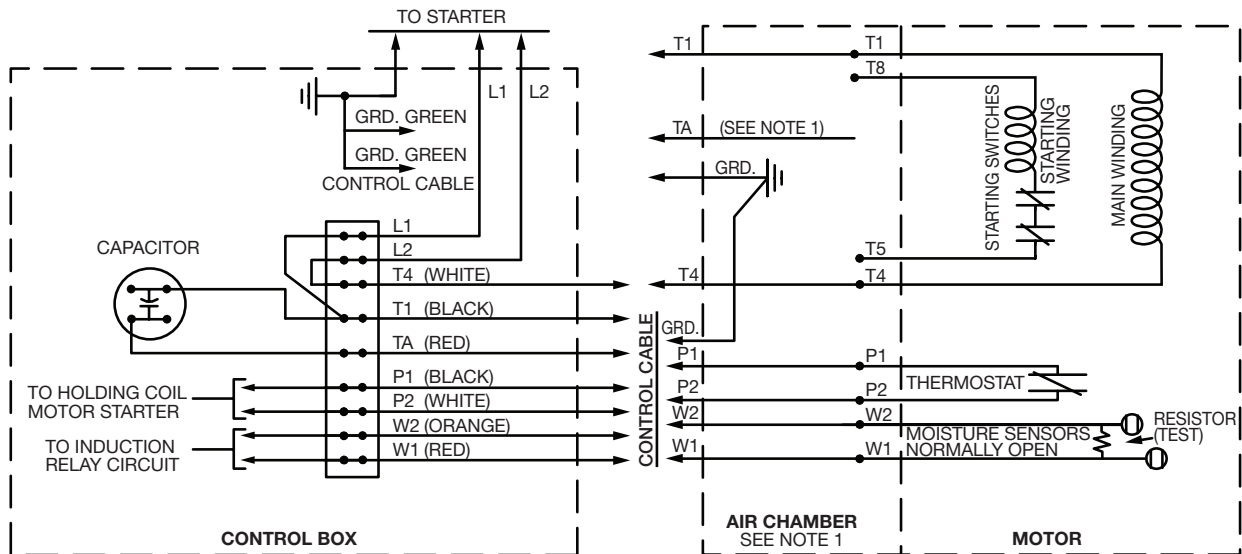

- NOTE 1:** IN MOTOR AIR CHAMBER CONNECT FOR DESIRED ROTATION PER WINDING DIAGRAM BELOW.
- NOTE 2:** MOTOR IS PROVIDED WITH A NORMALLY CLOSED THERMOSTAT, CONNECT P1 AND P2 IN SERIES WITH STARTER HOLDING COIL. THERMOSTAT CURRENT MUST NOT EXCEED 2 AMPS AT 125 VOLTS OR 1 AMP AT 250 VOLTS. DO NOT CONNECT P1 AND P2 IN SERIES WITH A MOTOR POWER LEAD.
- NOTE 3:** MOTOR IS FURNISHED WITH MULTICONDUCTOR POWER CABLE, THE COLOR CODING IS AS FOLLOWS:
T1 BLACK T4 WHITE TA RED GRD. GREEN

COUNTERCLOCKWISE ROTATION CLOCKWISE ROTATION

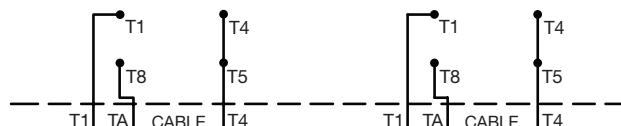

Baldor Explosion Proof AC and DC Motors Connection Diagrams

416820-102

**A-C MOTOR
CONNECTION DIAGRAM**
SINGLE PHASE CAPACITOR START INDUCTION RUN
DUAL VOLTAGE SUMP PUMP MOTOR CONTROL BOX

WIRING DIAGRAM FOR SINGLE PHASE CAPACITOR START INDUCTION RUN SUMP PUMP MOTOR CONTROL BOX

DUAL VOLTAGE CLOCKWISE AND COUNTERCLOCKWISE ROTATION (SEE NOTE 2)

THIS CONTROL BOX CONTAINS MOTOR STARTING WINDING CAPACITORS FOR ONE SPECIFIC MOTOR DESIGN AND IS NOT USABLE WITH A MOTOR HAVING A DIFFERENT DESIGN. THIS CONTROL BOX DOES NOT INCLUDE THE NECESSARY MOTOR STARTER WHICH SHOULD BE CONNECTED IN THE POWER CIRCUIT TO THIS CONTROL. ALSO, THIS CONTROL BOX DOES NOT INCLUDE THE NECESSARY INDUCTION RELAY WHICH MUST BE USED IN THE MOISTURE SENSOR CIRCUIT. CONNECT THE MOTOR AND CONTROL BOX FOR THE DESIRED ROTATION ACCORDING TO THE WIRING DIAGRAM AND NOTES BELOW.

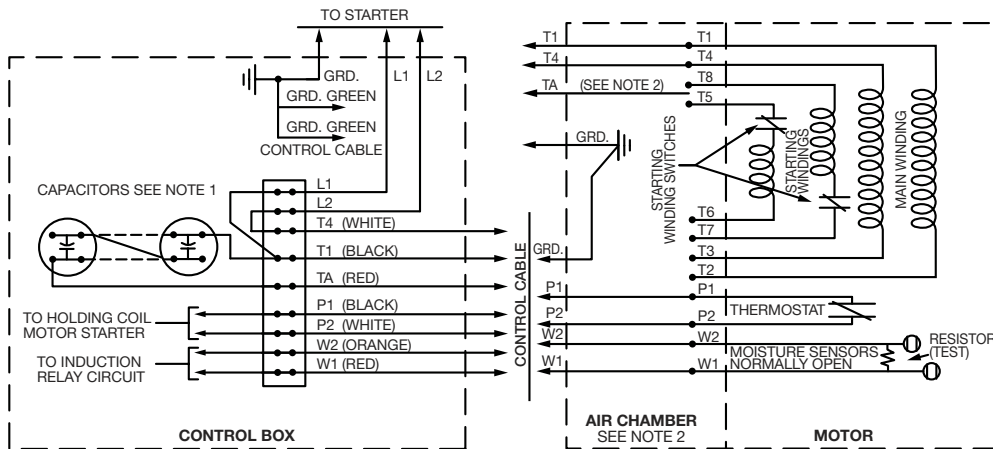

- NOTE 1: CAPACITOR CONNECTIONS: CONNECT IN SERIES AS INDICATED BY SOLID LINE FOR HIGH VOLTAGE AND IN PARALLEL AS INDICATED BY BROKEN LINES FOR LOW VOLTAGE.
- NOTE 2: IN MOTOR AIR CHAMBER CONNECT FOR DESIRED VOLTAGE AND ROTATION PER WINDING DIAGRAM BELOW.
- NOTE 3: MOTOR IS PROVIDED WITH A NORMALLY CLOSED THERMOSTAT, CONNECT P1 AND P2 IN SERIES WITH THE MOTOR STARTER HOLDING COIL. THERMOSTAT CURRENT MUST NOT EXCEED 2 AMPS AT 125 VOLTS OR 1 AMP AT 250 VOLTS. DO NOT CONNECT P1 AND P2 IN SERIES WITH A MOTOR POWER LEAD.
- NOTE 4: MOTOR IS FURNISHED WITH MULTICONDUCTOR POWER CABLE, THE COLOR CODING IS AS FOLLOWS:
T1 BLACK T4 WHITE TA RED GRD. GREEN

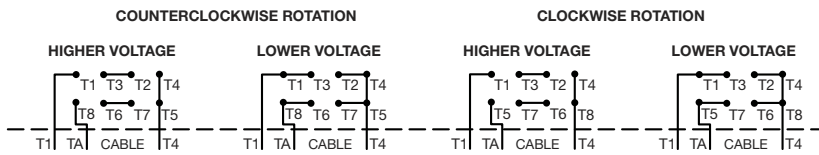

www.abb.com/motors&generators

We reserve the right to make technical changes or modify the contents of this document without prior notice. With regard to purchase orders, the agreed particulars shall prevail. ABB Ltd does not accept any responsibility whatsoever for potential errors or possible lack of information in this document.

We reserve all rights in this document and in the subject matter and illustrations contained herein. Any reproduction, disclosure to third parties or utilization of its contents - in whole or in part - is forbidden without prior written consent of ABB Ltd.

© Copyright 2012 ABB. All rights reserved.
Specifications subject to change without notice.

Baldor products ROW EN 2012-12 Printed in USA 5000 IBR454